

WARNING

DO NOT PLACE PLASTIC BOWL UNIT IN SERVICE WITHOUT METAL BOWL GUARD INSTALLED

Plastic bowl units are sold only with metal bowl guards. To minimize the danger of flying fragments in the event of plastic bowl failure, the metal bowl guards should not be removed. If the unit is in service without the metal bowl guard installed, manufacturer's warranties are void, and the manufacturer assumes no responsibility for any resulting loss.

IF UNIT HAS BEEN IN SERVICE AND DOES NOT HAVE A METAL BOWL GUARD, ORDER ONE AND INSTALL BEFORE PLACING BACK IN SERVICE..

CAUTION

Certain compressor oils, chemicals, household cleaners, solvents, paints and fumes will attack plastic bowls and can cause bowl failure. Do not use near these materials. When bowl becomes dirty replace bowl or wipe only with clean, dry cloth. Reinstall metal bowl guard or buy and install a metal bowl guard. Immediately replace any crazed, cracked, damaged or deteriorated plastic bowl with a metal bowl or a new plastic bowl and metal bowl guard.

SOME OF THE MATERIALS THAT WILL ATTACK POLYCARBONATE PLASTIC BOWLS.

Acetaldehyde	Chlorobenzene	Methylene chloride
Acetic acid (conc.)	Chloroform	Methylene salicylate
Acetone	Cresol	Milk of lime (CaOH)
Acrylonitrile	Cyclohexanol	Nitric acid (conc.)
Ammonia	Cyclohexanone	Nitrobenzene
Ammonium flouride	Cyclohexene	Nitrocellulose lacquer
Ammonium hydroxide	Dimethyl formamide	Phenol
Ammonium sulfide	Diozane	Phosphorous hydroxy chloride
Anaerobic adhesives and sealants	Ethane tetrachloride	Phosphorous trichloride
Antifreeze	Ethyl acetate	Propionic acid
Benzene	Ethyl ether	Pyridine
Benzoic acid	Ethylamine	Sodium hydroxide
Benzyl alcohol	Ethylene chlorohydrin	Sodium sulfide
Brake fluids	Ethylene dichloride	Styrene
Bromobenzene	Ethylene glycol	Sulfuric acid (conc.)
Butyric acid	Formic acid (conc.)	Sulphural chloride
Carbolic acid	Freon (refrig. & propell.)	Tetrahydronaphthalene
Carbon disulfide	Gasoline (high aromatic)	Tiophene
Carbon tetrachloride	Hydrazine	Toluene
Caustic potash solution	Hydrochloric acid (conc.)	Turpentine
Caustic soda solution	Lacquer thinner	Xylene
	Methyl alcohol	Perchloroethylene and others

TRADE NAMES OF SOME COMPRESSOR OILS, RUBBER COMPOUNDS AND OTHER MATERIALS THAT WILL ATTACK POLYCARBONATE PLASTIC BOWLS.

Atlas "Perma-Guard"	National Compound #N11
Buna N	"Nylock" VC-3
Cellulose #150 and #220	Parco #1306 Neoprene
Crylex #5 cement	*PermaBond #910
*Eastman 910	Petron PD287
Garlock #98403 (polyurethane)	Prestone
Haskel #568-023	Pydraul AC
Hilgard Co.'s hil phene	Sears Regular Motor Oil
Houghton & Co. oil #1120, #1130 & #1055	Sinclair oil "Lily White"
Houtosafe 1000	Stauffer Chemical FYRQUEL #150
Kano Kroil	Stillman #SR 269-75 (polyurethane)
Keystone penetrating oil #2	Stillman #SR 513-70 (neoprene)
*Loctite 271	Tannergas
*Loctite 290	Telar
*Loctite 601	Tenneco anderol #495 & #500 oils
Loctite Teflon-Sealant	Titon
Marvel Mystery Oil	*Vibra-tite
Minn. Rubber 366Y	Zerex

*When in raw liquid form.

WE CANNOT POSSIBLY LIST ALL HARMFUL SUBSTANCES, SO CHECK WITH MOBAY CHEMICAL OR THE GENERAL ELECTRIC OFFICE FOR FURTHER INFORMATION ON POLYCARBONATE PLASTIC.

CAUTION

EXCEPT as otherwise specified by the manufacturer, this product is specifically designed for compressed air service, and use with any other fluid (liquid or gas) is a misapplication. For example, use with or injection of certain hazardous liquids or gases in the system (such as alcohol or liquid petroleum gas) could be harmful to the unit or result in a combustible condition or hazardous external leakage. Manufacturer's warranties are void in the event of misapplication, and manufacturer assumes no responsibility for any resulting loss. Before using with fluids other than air, or for non-industrial applications, or for life support systems consult manufacturer for written approval.

(see reverse side for Installation and Maintenance Instructions)

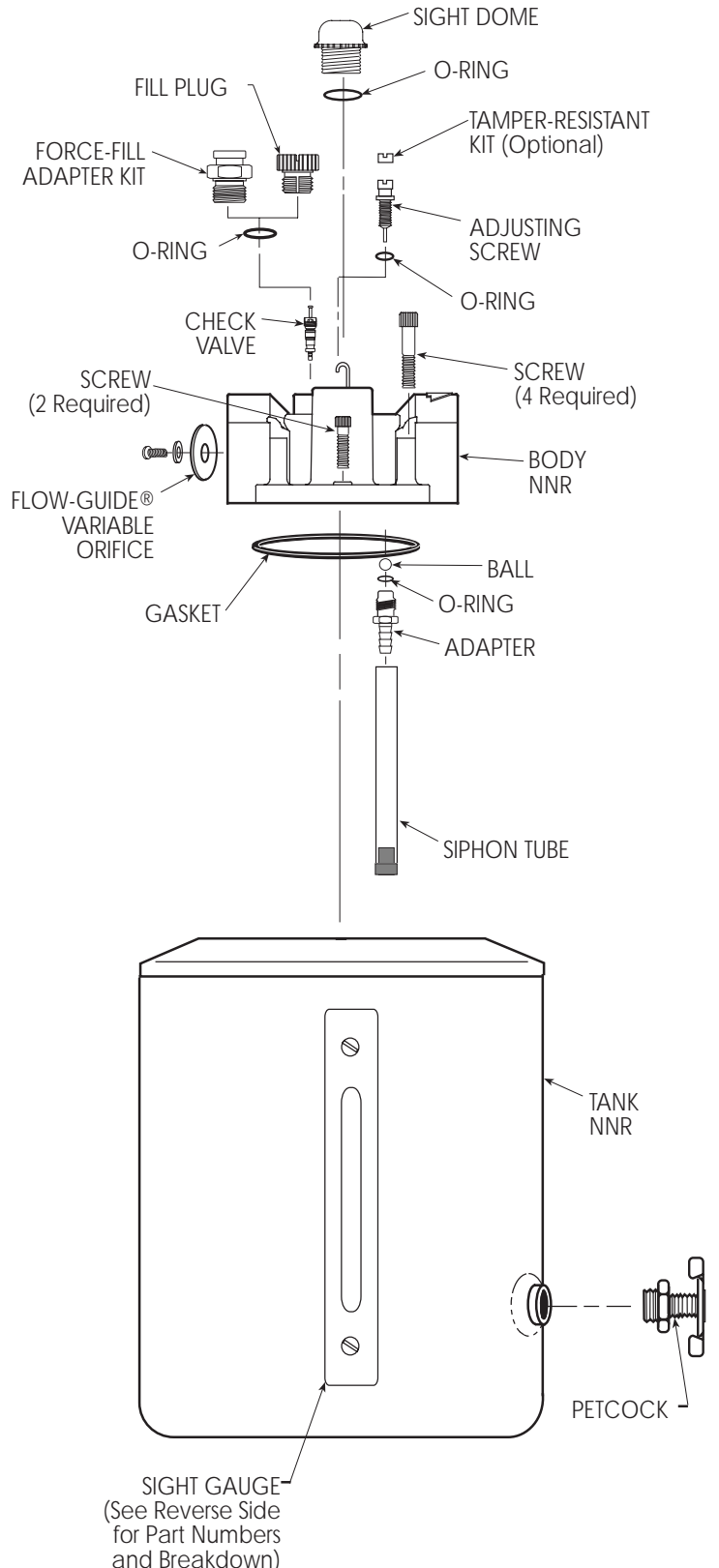

NNR=NOT NORMALLY REPLACED

83-300-000 REV REL 8/95
Printed in the U.S.A.

INSTALLATION

- 1.Refer to the warning on front page.
- 2.Install as close as possible to the equipment requiring lubrication.
- 3.Install the unit with the air moving through the body in the direction indicated by the arrow.
- 4.Install a unit with the same pipe size as the line in use. Avoid using fittings, couplings, etc., that restrict the airflow or baffle the oil out of the air at the lubricator outlet.
- 5.The unit may be filled under pressure by removing the fill plug and pouring the oil into a bowl through the fill port. The bowl may be taken off after the fill plug is removed if a more rapid fill is required. **DO NOT** replace the fill plug until the bowl and bowl guard are in position and the clamp ring is locked in place. **NOTE:** As the fill plug is removed, the air pressure in the bowl will be released.
- 6.Use only clean nondetergent oil. SAE 10 or lighter is usually best.
- 7.The rate of oil delivery may be controlled by turning the adjusting screw counterclockwise for more and clockwise for less oil delivery. This lubricator delivers all the oil downstream which passes through the sight dome. The oil delivery rate will change automatically to deliver more oil during higher airflows and less oil for airflows lower than that at which the original setting was made.
- 8.Maximum pressure and temperature ratings for metal tanks are 200 psig (14 bar) and 175°F (79°C).

MAINTENANCE

1. Given clean operating conditions, this unit will be trouble-free. Contaminants from dirty oil may collect on the siphon tube inlet filter, requiring the filter to be cleaned by tapping on a hard surface and blowing off with an air blow gun.
2. If the oil delivery rate drops, the lubricator should be cleaned. Shut off air supply and reduce pressure in unit to zero. Remove the Flow-Guide® variable orifice screw and clean its air passage with a small wire. Check the bore that the screw fits into for contaminants and clean, if necessary. Be sure that the passageway from the sight dome cavity into the Flow-Guide® variable orifice post is open. Remove the adjusting screw and clean the needle and the seat in the body. Inspect and clean the passage from the needle seat down into the adapter.
3. Drain off any contaminants which collect in the bottom of the bowl.
4. Lubricate o-rings with Parker O-Lube before assembly.
5. Clean plastic bowl with a clean, dry cloth only.

KITS AND REPLACEMENT PARTS

Repair Kit -(O-Rings) (for L41 and L42).....	LRP-95-061
Siphon Tube Assembly Kit (for L41)	LRP-96-182
Siphon Tube Assembly Kit (for L42)	LRP-96-211
Fill Plug Kit (for L41 and L42)	LRP-95-250
Flow-Guide® Variable Orifice Kit (for L41 and L42)	LRP-95-251
Sight Dome Kit (for L41 and L42)	LRP-95-249
Sight Gauge Kit (for L41)	LRP-95-771
Sight Gauge Kit (for L42)	LRP-95-716
Tamper Resistant Kit	LRP-95-587
Force-Fill Adapter (for L41 and L42).....	LRP-96-420
Check Ball and O-Ring Kit	LRP-95-310

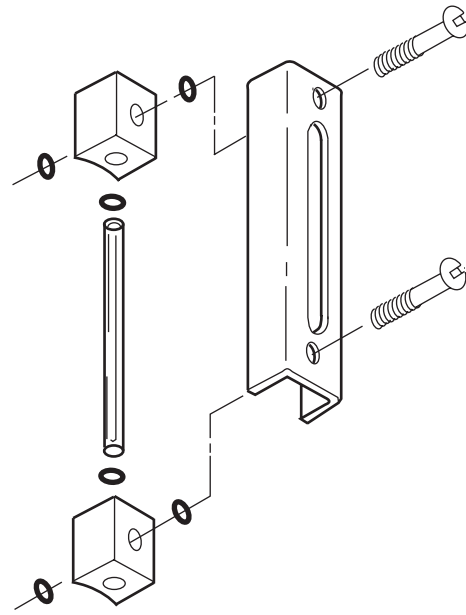

SIGHT GAUGE KIT