

CLIF MOCK™

True Cut 2000 Sampler Controller

User Manual



Important Safety Information

Symbols and Terms Used in this Manual



WARNING: This symbol identifies information about practices or circumstances that can lead to personal injury or death, property damage, or economic loss.

CAUTION: Indicates actions or procedures which if not performed correctly may lead to personal injury or incorrect function of the instrument or connected equipment.

Important: Indicates actions or procedures which may affect instrument operation or may lead to an instrument response which is not planned.

Technical Support Contact Information

Cameron
Measurement Systems Division
14450 John F. Kennedy Blvd.
Houston, TX 77032
Phone: 1-800-654-3760; 281-582-9500
Fax: 281-582-9599

Clif Mock is a trademark of Cameron International Corporation (“Cameron”).
Modbus is a registered trademark of the Modbus Organization, Inc.

© 2011 Cameron International Corporation (“Cameron”). All information contained in this publication is confidential and proprietary property of Cameron. Any reproduction or use of these instructions, drawings, or photographs without the express written permission of an officer of Cameron is forbidden.

All Rights Reserved.
Printed in the United States of America.

Manual No. 9A-70165002, Rev. 01
June 2011

Contents

Section 1—Description	5
Display	6
Power Supply	6
Solenoid.....	6
Product Identification	7
Table 1.1—True Cut 2000 Sampler Controller Specifications	7
Section 2—Installation.....	9
General Information.....	9
Mounting Options	9
Tubing Connections.....	10
Field Wiring.....	11
Lithium Battery	12
Solar Panel and Rechargeable Battery.....	12
External DC Power Supply	12
Communication	13
Turbine Input.....	13
Pulse Input	14
Digital Output 1 (Solenoid Driver)	15
Digital Output 2 (Solenoid Driver)	16
Digital Output 2 (Pulse Output).....	17
Section 3—Operating the Controller	19
Front Panel.....	19
Keypad Overview.....	19
Common Keypad Functions.....	20
On-Demand Display of Status Indicators and Volumes	20
Table 3.1—Performance and Job Status Indicators.....	21
Section 4—Programming the Controller	23
Power Supply Selection	23
Time-Based Sampling.....	23
Continuous Time Sampling	24
Volume-Based Sampling.....	24
Sampler Test.....	26
Battery Life Reset (Lithium-Powered Devices Only).....	27
Keypad Security	27
Section 5—Spare Parts	29
Table 5.1—Spare Parts	29
Table 5.2—Optional Accessories	29
Appendix A—Lithium Battery Information	A-1
Lithium Battery Disposal.....	A-1
Transportation Information	A-1
Appendix B—Communications Protocol	B-1
Introduction.....	B-1
Supported Commands	B-1
Data Types	B-1
Registers	B-1

Section 1—Description

The Clif Mock True Cut 2000 Sampler Controller (Figure 1.1) is an electronic controller that can be used to control any pneumatic device. When paired with a liquid/gas sample pump, the device is ideal for sampling liquid or gas flow streams.

The controller can be configured to act as a timer or a pulse counter for sampling product in proportion to time or volume. This design allows external pacing devices such as positive displacement meters, turbines meters, or dry contact closures from computers to control the sampling frequency.

The controller consists of a weatherproof fiberglass enclosure with a window for viewing a dual LCD and a six-key keypad (Figure 1.1), a solenoid, battery pack and electronic circuitry (Figure 1.2, [page 6](#)).

With three different power options, the device can be used in a variety of applications and locations. A lithium battery pack typically provides autonomous power for 15 months or longer when the device is configured for 30-minute sampling intervals. Where solar power is desired, the controller is equipped with a rechargeable lead acid battery. An external DC power supply can also be used to power the device, in which case the lithium battery provides backup protection.

The controller supports inputs from both turbine meters and pulse-generating devices such as the contact closure input of a positive displacement meter. Frequency settings for pulse inputs can be read from a preconfigured EFM device or entered manually.

While external communications are not required for operating the True Cut 2000 controller, external Modbus communicating devices or Modbus SCADA systems can be connected to the controller for collecting real-time data or for configuring the controller remotely.

The unit is CSA certified as an intrinsically safe device for use in Class I, Division 1, Groups C and D hazardous areas when installed in accordance with Cameron instructions. See Table 1.1, [page 7](#) for a complete list of specifications.



Figure 1.1—True Cut 2000 Sampler Controller

Display

Dual readouts in the front panel display provide a real-time sample count during operation and guide users through configurable settings during device setup. In addition, a user can initiate a scrolling display of performance status indicators and total volumes on demand during normal operation. Run time, percentage of sample job completion, flow rate, total volume, grand volume, system voltage, battery life, sampler status, firmware version, and sample count are recorded by the controller and available for display. See Section 3, [page 19](#), for details.

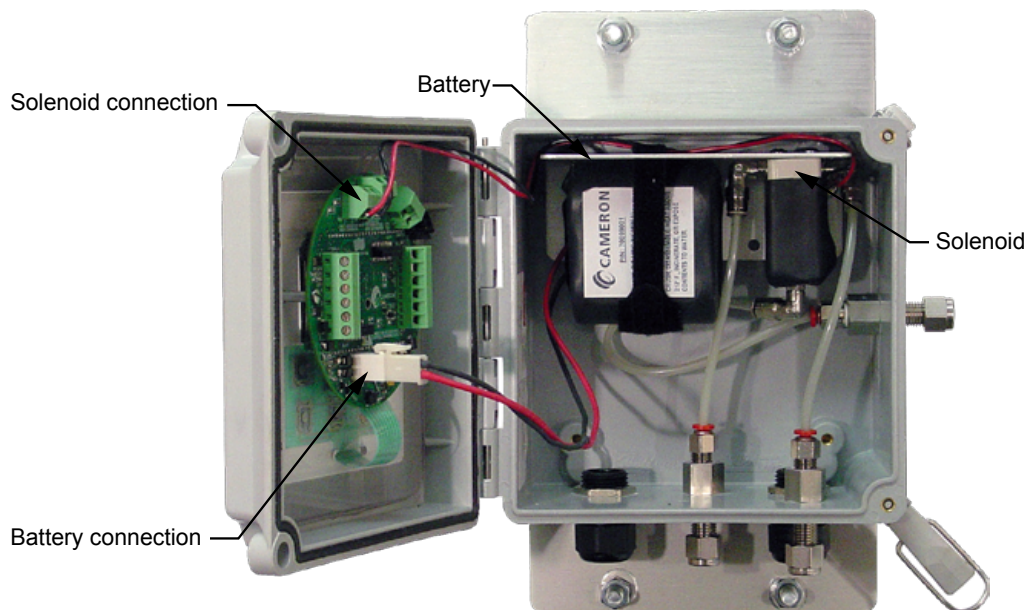

Figure 1.2—True Cut 2000 Sampler Controller, internal view

Power Supply

The True Cut 2000 Sampler Controller supports three different power supplies.

- The 7.2V lithium battery pack, shown in Figure 1.2, provides autonomous power for 15 months or longer when the device is configured for 30-minute sampling intervals. A battery life indicator is built into the controller to provide a reminder when it's time to change the battery.
- An external 9V to 15V DC power supply can be coupled with an I.S.-rated safety barrier in the safe area and wired to the controller circuit board.
- A 6V solar panel can be pole-mounted and connected to a 6V rechargeable lead acid battery supplied with the controller. The battery mounts inside the enclosure using the Velcro[®] strap shown in Figure 1.2.

Solenoid

The solenoid, shown in the upper right corner of the enclosure in Figure 1.2, connects to an air supply and to the controller circuit board. When the controller is installed as part of a sampling system, the solenoid is activated by the controller circuit to direct air pressure to a sample pump, initiating the sampling process.

The air supply may be either an external customer-supplied air supply (for liquid sampling, hazardous gas applications, or low-pressure gas applications) or pipeline gas. A regulator, which is sold separately, maintains the incoming air pressure being fed to the solenoid at a maximum of 100 psi (standard solenoid) or 120 psi (stainless steel solenoid).

A solenoid vent fitting mounted in the right side panel of the enclosure allows gases escaping from the solenoid to be safely vented from the enclosure. In hazardous gas applications, an approved device can be connected to the vent for collecting the gas during sampling operations. A short length of tubing connects the vent to a fitting in the bottom of the solenoid.

Product Identification

A serial tag mounted to the outside of the enclosure identifies the product by its part number and serial number (Figure 1.3). When the True Cut 2000 controller is sold as part of the LGS-2000 sampling system, the maximum working pressure of the pump (LGS-2000 WP) will be stamped on the tag, along with the working pressure of the controller (Solenoid Max WP). Each tag is also marked to show which battery pack is installed and the temperature range for which it is rated.



TRUE CUT 2000 CONTROLLER / LGS-2000 SAMPLER	
PART NO. <input type="text"/>	<input type="checkbox"/> BATTERY PACK 9A-70099001 TEMP, AMB: -40°C to 60°C
SERIAL NO. <input type="text"/>	<input type="checkbox"/> BATTERY PACK 2296075-01 TEMP, AMB: -40°C to 40°C
SOLENOID MAX WP <input type="text"/> PSI	<input type="checkbox"/> BATTERY PACK 2296472-01 TEMP, AMB: -40°C to 40°C
LGS-2000 MAX WP <input type="text"/> PSI	"INTRINSICALLY SAFE/SECURITE INTRINSEQUE" AS PER INSTALLATION INSTRUCTIONS X-310744
 CLASS I, DIV. 1, GROUPS C AND D Type 4X, T3 167018	USE ONLY WITH BATTERY PACK P/N: 9A-70099001, 2296075-01, OR 2296472-01. WARNING: SUBSTITUTION OF COMPONENTS MAY IMPAIR INTRINSIC SAFETY AVERTISSEMENT: LA SUBSTITUTION DE COMPOSANTS PEUT COMPROMETTRE LA SECURITE INTRINSEQUE
FOR OPERATING AND MAINTENANCE INFO, SEE TRUE CUT 2000 MANUAL 9A-70165002 OR LGS-2000 MANUAL 9A-70165003.	
	Measurement Systems

Figure 1.3—Serial tag

Table 1.1—True Cut 2000 Sampler Controller Specifications

Enclosure	Weatherproof fiberglass, 2-in. pole or bulkhead mount, with 6-key keypad
Power Supply	Integral 7.2V lithium battery pack, standard
	Rechargeable 6V lead acid battery and 6V solar panel
	9-15V external power supply
Operating Environment	-40°F to 140°F (-40°C to 60°C) or -40°F to 104°F (-40°C to 40°C), battery dependent
	0 to 90% non-condensing relative humidity
	LCD contrast is reduced below -22°F (-30°C)
Turbine Meter Input (cont'd on next page)	Configurable sensitivity adjustment (20 mV to 200 mV, peak to peak)
	Frequency range: 0 to 5000 Hz
	Continuous 50/50 duty cycle
	Programmable K-factor
	Cannot be used simultaneously with Pulse Input

Turbine Meter Input (cont'd)	Input amplitude: 20 mV to 3000 mV, peak to peak				
	Turbine Setting	Input Sensitivity			
		0 – 1000 Hz	1000 – 2000 Hz	2000 – 3500 Hz	3500 - 5000 Hz
	Low (20 mV)	20 mVpp	25 mVpp	50 mVpp	50 mVpp
	Med (50 mV)	50 mVpp	70 mVpp	110 mVpp	140 mVpp
	High (100 mV)	100 mVpp	150 mVpp	250 mVpp	350 mVpp
	Highest (200 mV)	200 mVpp	380 mVpp	620 mVpp	850 mVpp
Pulse Inputs 1 and 2	Accept a signal from a turbine meter or positive displacement meter				
	Optically isolated				
	Input: 3 to 15 VDC or contact closure				
	Pulse Input 2 dedicated to sampling termination				
Volume Measurement Accuracy	±1 least significant digit				
LCD Display	8-digit top readout of values (7-segment characters)				
	6-digit bottom readout of scrolling parameters and associated engineering units (11-segment characters for easy-to-read prompts)				
	0.3" character height				
	Configurable scan parameters and duration				
Digital Outputs 1 and 2	Digital Output 1, solenoid drive, rated for 300 mA max at 6 VDC				
	Digital Output 2, solenoid drive or pulse output, rated for 60 mA max at 15 VDC				
Sampling Methods (Time)	Batch Sampling (controller calculates the frequency of samples required to fill the bottle in a specified time)				
	Time Sampling (controller collects samples at user-configured frequency until specified number of samples is collected)				
	Continuous Time Sampling (controller collects samples at user-configured frequency until sampling period is manually terminated)				
Sampling Methods (Volume)	Preconfigured Pulse Input (controller collects samples to deliver specified volume, based on pulse input from a preconfigured EFM device)				
	Manually Entered Pulse Input (controller collects samples to deliver specified volume, based on manually-entered pulse input frequency settings)				
	Turbine Input (controller collects samples to deliver specified volume, based on turbine input frequency settings)				
Volume Units	GAL, BBL, M3, LIT, CF, and NONE				
Rate Units	/SEC, /MIN, /HR, and /DAY				
Maximum Air Pressure to Solenoid	100 psi (standard solenoid)				
	120 psi (stainless steel solenoid)				
Security	Two security levels with password protection				
Communications	2 RS-485 communication ports (RTU Modbus®)				
Safety Approval	Intrinsically Safe - Class I, Division 1, Groups C and D for use in the US and Canada				

Section 2—Installation

General Information

The True Cut 2000 Sampler Controller is typically installed after the sample probe and flowmeter are installed in a pipeline.

For sampling liquid or gas, the controller should be installed with a sample pump, a sample probe, a pressure regulator, a flowmeter, and a receiver. In liquid applications, hazardous gas applications, and low-pressure gas applications, an external air supply is also required.

Important: This manual describes only the installation of the True Cut 2000 controller. See manufacturer instructions for help in installing other components of a sampling system. If the controller was purchased as part of the LGS-2000 Sampling System, refer to the LGS-2000 Sampling System User Manual for installation instructions.

CAUTION: If the controller is equipped with a lithium battery, place the device in a well-ventilated area before opening the enclosure. Under normal operating conditions, the lithium battery that powers the True Cut 2000 is a sealed unit and poses no hazard when the enclosure is opened. However, a leak in a lithium battery could expel toxic fumes into the enclosure.

If the battery appears to be damaged, adhere to the safety precautions and follow the disposal instructions provided in Appendix A, [page A-1](#).

Mounting Options

The controller may be mounted to a flat surface or to a 2-in. vertical pipe using the mounting brackets provided (Figure 2.1) and a set of U-bolts (sold separately or provided by customer).

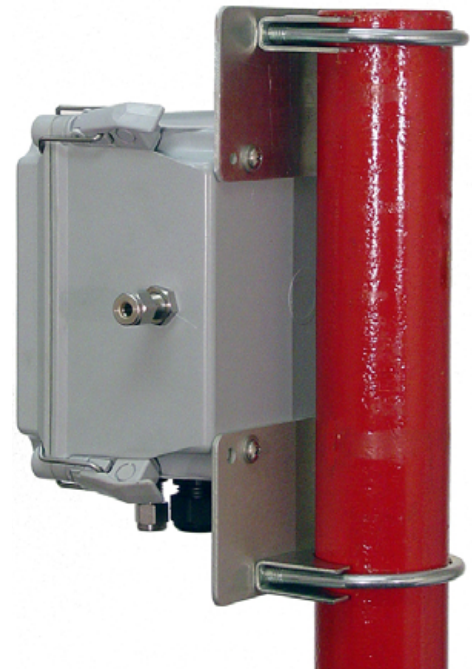

Figure 2.1—Two-piece mounting bracket

Tubing Connections

Tubing arrangements vary, depending on the product sampled (gas or liquid) and site restrictions. At a minimum, 1/4-in. stainless steel tubing is required to

- connect the incoming air from a regulator to the True Cut 2000 solenoid
- connect the outgoing air supply from the True Cut 2000 solenoid to a sample pump

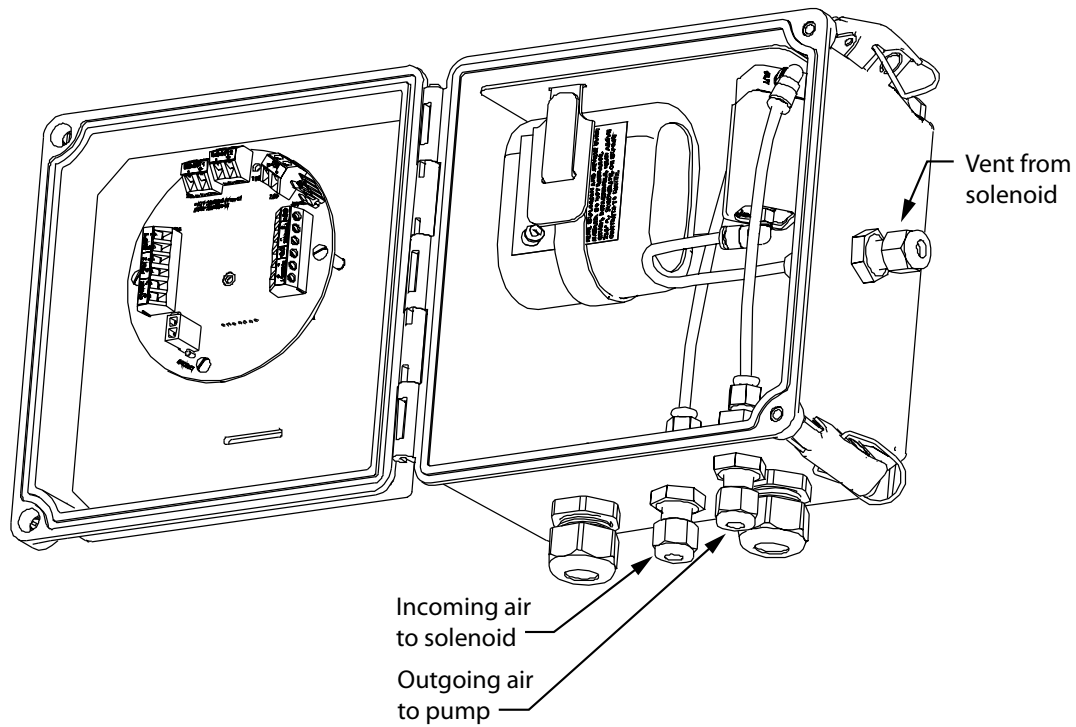

Figure 2.2—Conduit entries and cord grips

Field Wiring

CAUTION: All field wiring must conform to the National Electrical Code, NFPA 70, Article 501-4(b) for installations within the United States or the Canadian Electric Code for installations within Canada. Local wiring ordinances may also apply. All field wiring must be rated for temperatures of 194°F (90°C) or higher, and have a wire range of 22 to 14 AWG. Terminal block screws must be tightened to a minimum torque of 5 to 7 in-lbs. to secure the wiring within the terminal block. Only personnel who are experienced with field wiring should perform these procedures.

To wire the True Cut 2000 for operation, open the door of the enclosure to access the circuit board. Complete the following field connections, referencing Figure 2.3 for terminal block locations.

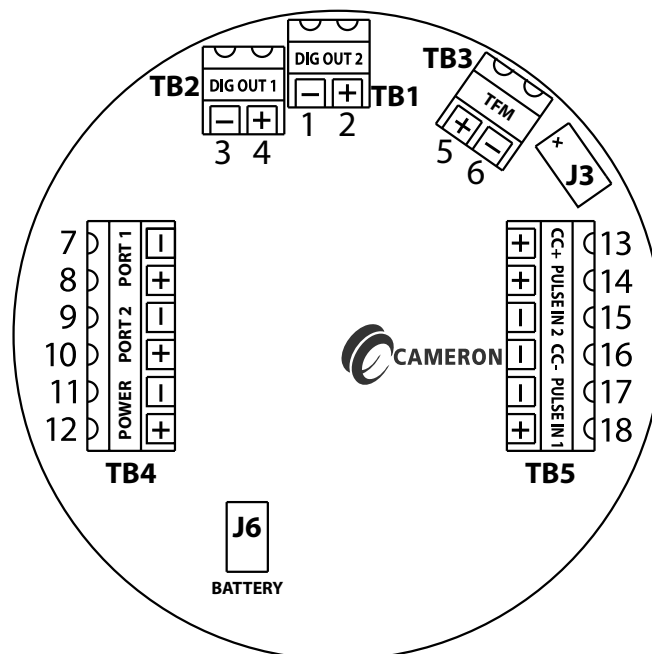

Figure 2.3—Terminal block layout

1. Connect the power supply. See Figures 2.4 through 2.6, [page 12](#).
2. Connect a Modbus communications device to TB4 Port 1 or Port 2 terminals, if desired. See Figure 2.7, [page 13](#).
3. If a turbine flowmeter input will be used to indicate volume, connect the signal cable to terminal block TB3. Route the cable through a cord grip and tie a loose knot in the cable or install a cable tie inside the enclosure, allowing enough cable length to connect the wires to the TB3 terminals. See Figure 2.8, [page 13](#).
4. If a positive displacement meter or other pulse-generating device will be used to indicate volume, connect the appropriate switch or pulse-generating device to TB5. See Figures 2.9 through 2.12, [page 14](#).
5. Connect the solenoid wires to the TB2 (DIG OUT 1) or TB1 (DIG OUT 2) terminals. If using a solenoid with a voltage rating greater than 6V, the signal must be transmitted through an I.S.-rated safety barrier installed in the safe area. See Figures 2.13 through 2.17, [page 15](#) through [page 17](#).
6. Ensure that all cables are secured inside the enclosure before closing the door and securing the hinges.

Lithium Battery

The lithium battery two-conductor cable is fitted with a connector that plugs directly into the J6 connector on the True Cut 2000 circuit board.

Use only battery pack Part No. 9A-70099001 or Part No. 2296075-01 for battery replacement. The lithium battery is also available as a backup supply when the True Cut 2000 is purchased for use with external DC power. The lithium battery pack is rated to power the device for 15 months or longer when the device is configured for 30-minute sampling intervals, and has a significantly longer life when used for backup power only.

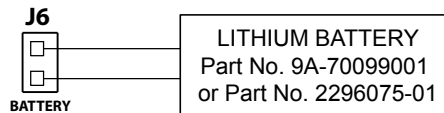

Figure 2.4—Lithium battery wiring diagram

Solar Panel and Rechargeable Battery

Where solar power is desired, the True Cut 2000 controller can be supplied with a rechargeable lead acid battery for use with a 6V solar panel. The battery has two cable leads; the black microconnector connects to the solar panel cable and the larger white connector connects to the J6 battery connector on the circuit board. Use only battery Part No. 2296472-01 for battery replacement.

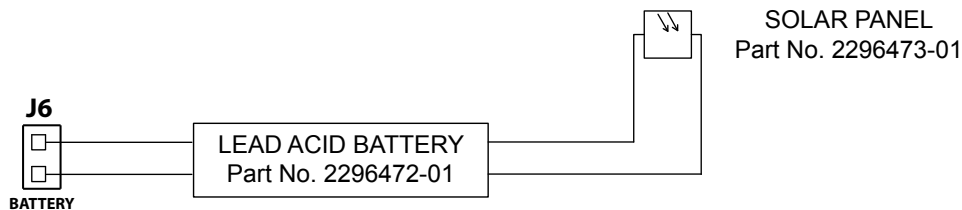

Figure 2.5—Solar power wiring diagram

External DC Power Supply

The True Cut 2000 can be connected to a customer-supplied 9-15 VDC power supply by a two-conductor cable. If the controller is installed in a hazardous area, the cable must be routed through an I.S.-rated safety barrier in the safe area. The barrier must be rated for 15V maximum and 40 ohms minimum. The power supply and cable must be capable of supplying 9 to 15 VDC @ 375 mA through the intrinsic safety barrier.

The external power supply must be an approved SELV source, insulated from the AC main by double/reinforced insulation per CSA C22.2 No. 61010-1-04/ UL 61010-1 – 2nd Edition.

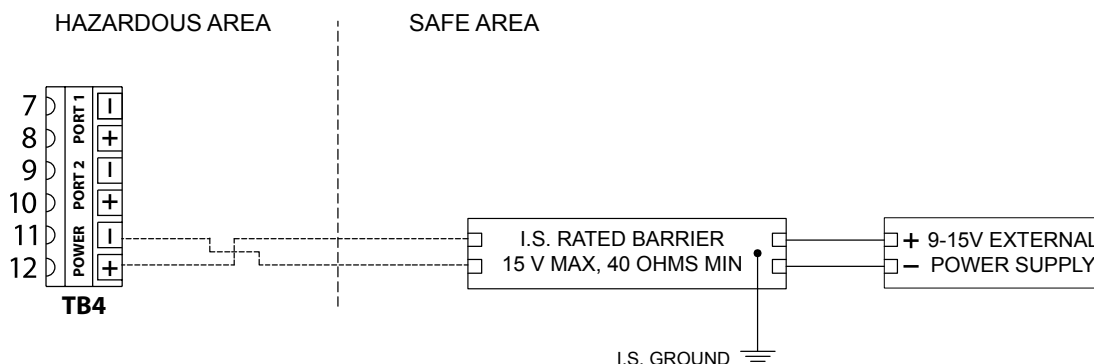

Figure 2.6—External DC power wiring diagram

Terminal 11 (POWER -) may be wired through a separate barrier channel, the I.S. ground return, or a diode barrier return.

Important: A switch or circuit breaker must be included in the safe area external power supply installation within easy reach of the operator. The switch or circuit breaker must be marked as the “disconnect” for the external DC power supply.

Communication

Two RS-485 communication ports (COM1 and COM2) are available for use with any device that is capable of reading Modbus data. An intrinsic safety barrier must be installed to prevent a safe area power surge from traveling back into the hazardous area.

Communications connections are not required for basic operation of the controller.

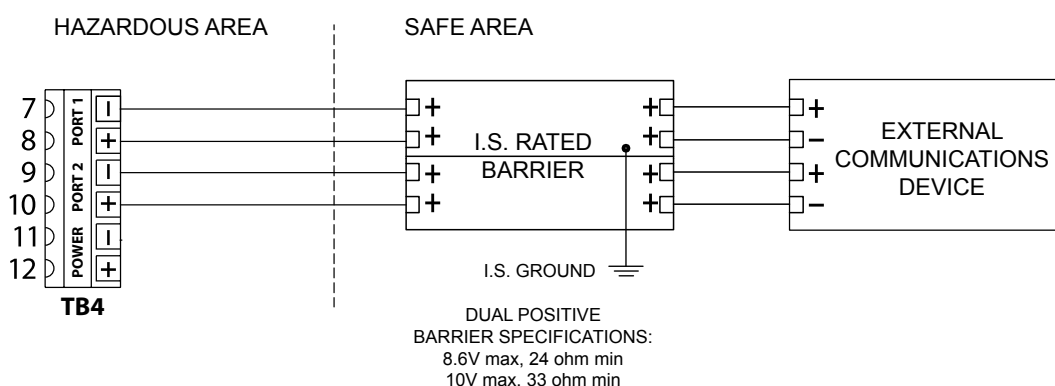

Figure 2.7—RS-485 communications wiring diagram

Turbine Input

The flowmeter input can be provided by the magnetic pickup of a turbine flowmeter. This input enables the True Cut 2000 to calculate and display flow rates and accumulated totals. The controller can detect a magnetic pickup signal in the range of 20 mV to 3000 mV, peak to peak. Only turbine meters that meet the required entity parameters may be used with this input.

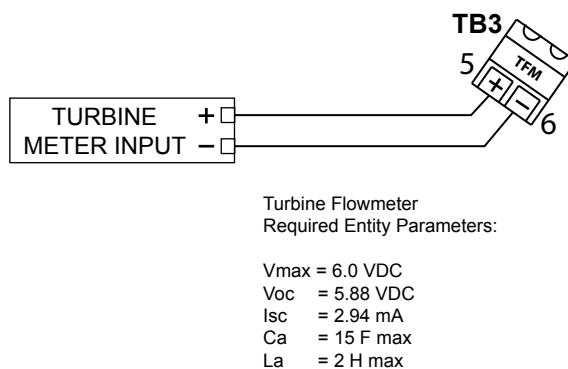

Figure 2.8—Turbine flowmeter input wiring diagram

Pulse Input

If a pulse from a dry contact or open collector switch or from a positive displacement meter or turbine/ pre-amplifier will be used to indicate volume, connect the switch or device to the Pulse Input 1 terminals as shown in Figures 2.9 through 2.12. Pulse Input 1 provides an optically isolated input for high-amplitude pulse (frequency) signals and can accept signals from 3V to 15V.

Important: To terminate a sampling period remotely, Pulse Input 2 can be connected to a second switch or pulse generator and wired using Pulse IN 2 terminals. Pulse Input 2 can accept signals from 3V to 15V. PULSE INPUT 2 CAN ONLY BE USED FOR SAMPLING TERMINATION.

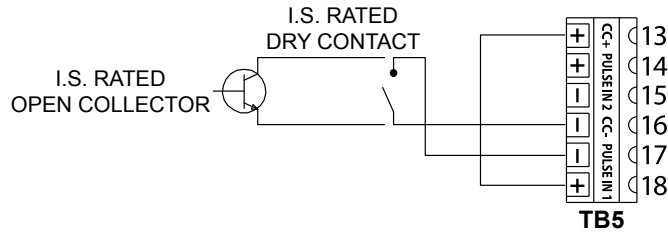

Figure 2.9—Pulse input wiring diagram for use with an I.S.-rated dry contact or open collector input

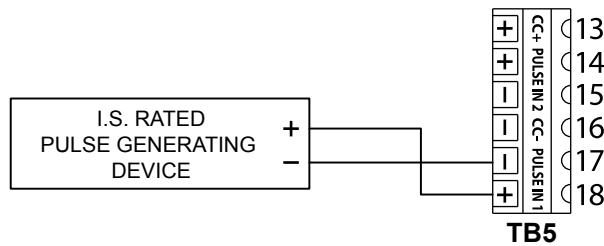

Figure 2.10—Pulse input wiring diagram for use with an I.S.-rated pulse generating device

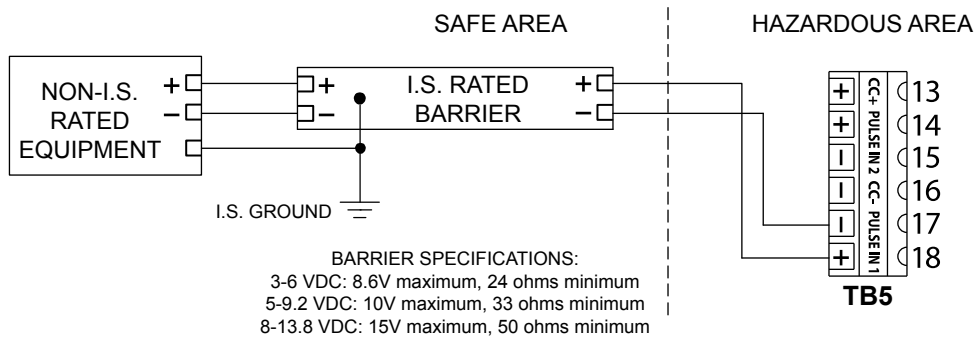

Figure 2.11—Pulse input wiring diagram for use with non-I.S.-rated equipment

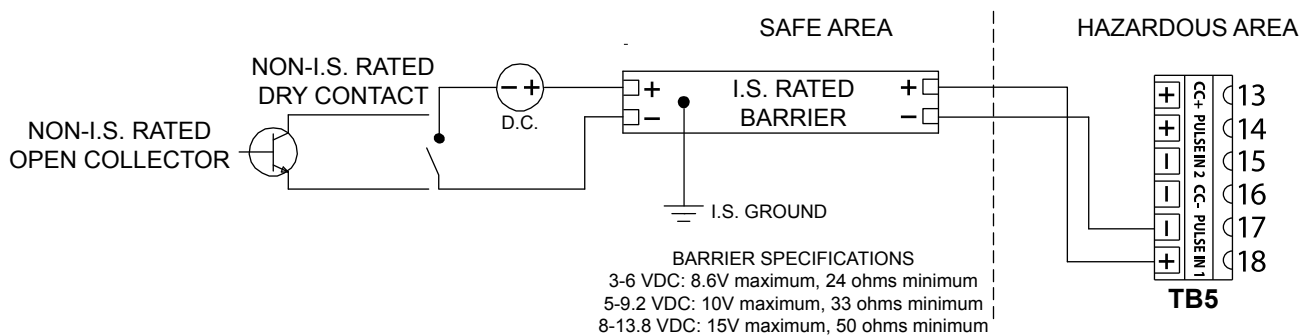

Figure 2.12—Pulse input wiring diagram for use with non-I.S.-rated dry contact or open collector input

Digital Output 1 (Solenoid Driver)

The True Cut 2000 provides two digital output ports. Either output can be used to drive the solenoid. The preferred output for a given application depends largely on the voltage rating of the solenoid.

Digital Output 1 is a transistor that can drive the integrated 6V solenoid directly without external power (Figure 2.13). Alternatively, when a higher voltage solenoid is required, Digital Output 1 can also be used to drive a relay which in turn drives the solenoid through an I.S.-rated barrier (Figure 2.14). The solenoid, relay, solenoid driver, and external power supply must have equivalent voltage ratings.

The maximum rating of Digital Output 1 circuit is 300 mA at 6 VDC.

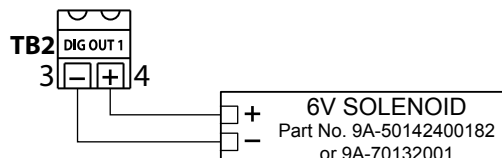

Figure 2.13—Solenoid wiring diagram for use with 6V solenoid supplied with controller

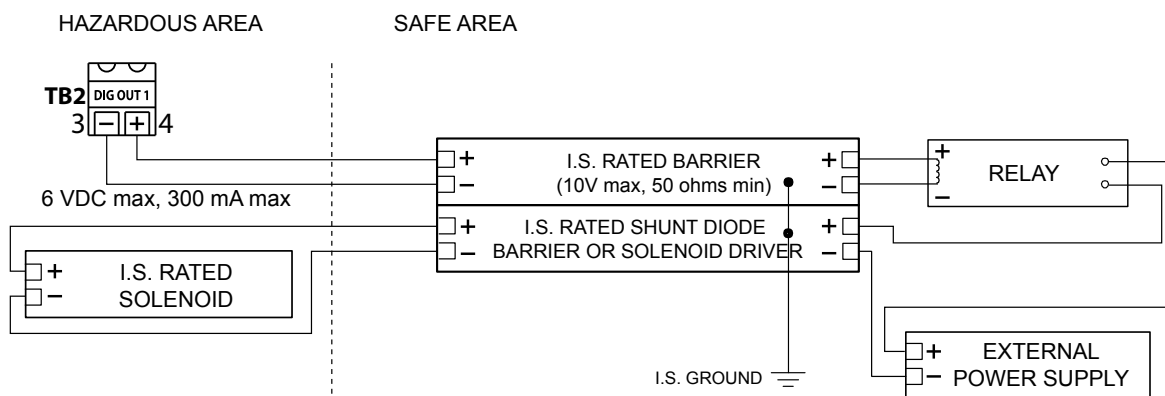

Figure 2.14—Solenoid wiring diagram for use with customer-supplied solenoids (>6V). This wiring option uses a relay for control; therefore, no control logic is required in the driver.

Digital Output 2 (Solenoid Driver)

Digital Output 2 is a solid-state relay that can be used to drive a solenoid rated for 15V or less with an I.S.-rated barrier and a 9-15V external power supply (Figure 2.15), provided that the 60mA of current provided by the barrier is sufficient to drive the solenoid.

Alternatively, when a higher voltage solenoid is required, Digital Output 2 can be used with an I.S.-rated barrier, a solenoid driver with control logic, and an external power supply to drive the solenoid (Figure 2.16). The solenoid, solenoid driver, and external power supply must have equivalent voltage ratings.

The maximum rating of the Digital Output 2 circuit is 60mA at 15 VDC.

When a second solenoid driver is not required, Digital Output 2 can be used as a simple pulse output to a readout device. See [Digital Output 2 \(Pulse Output\)](#), page 17.

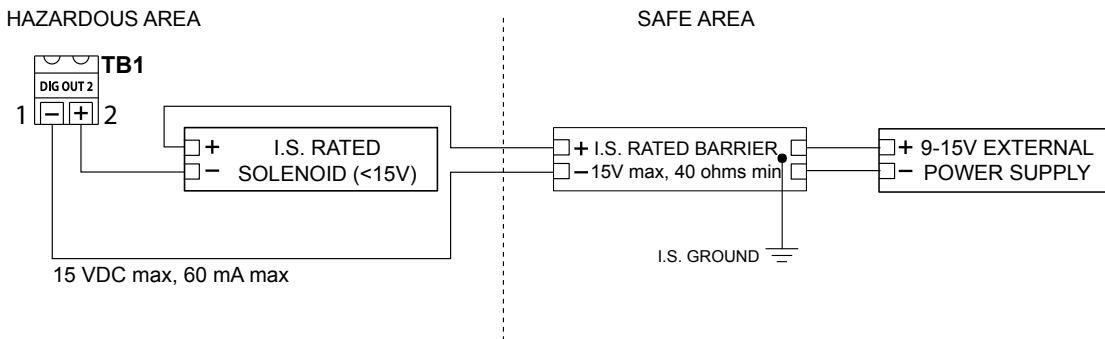

Figure 2.15—Solenoid wiring diagram for use with 6-15V solenoids

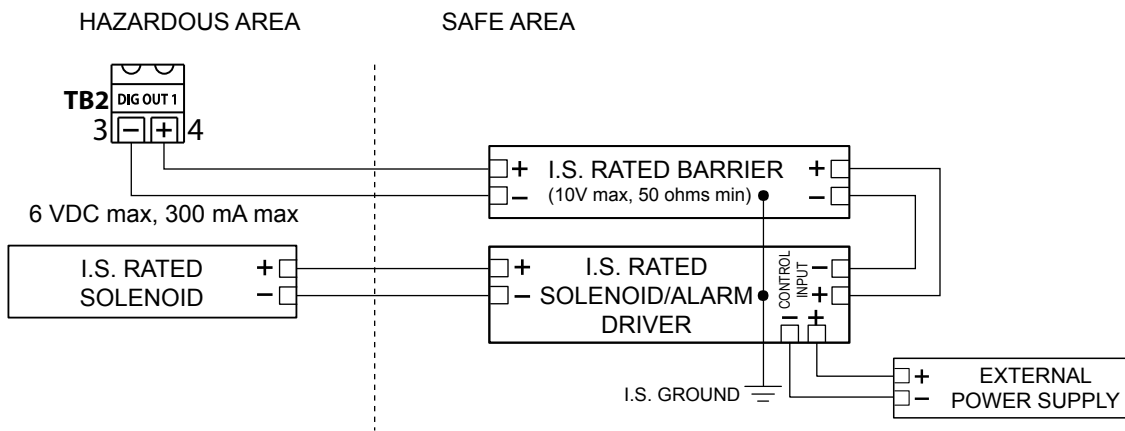

Figure 2.16—Solenoid wiring diagram for use with customer-supplied solenoids (typically >6V). This wiring option requires an I.S.-rated solenoid/alarm driver with control logic to drive the solenoid.

Digital Output 2 (Pulse Output)

Digital Output 2 can be used as a simple pulse output to send a simultaneous secondary output to a pulse readout device whenever a primary solenoid drive signal is generated by Digital Output 1.

The maximum rating of the Digital Output 2 circuit is 60 mA at 15 VDC.

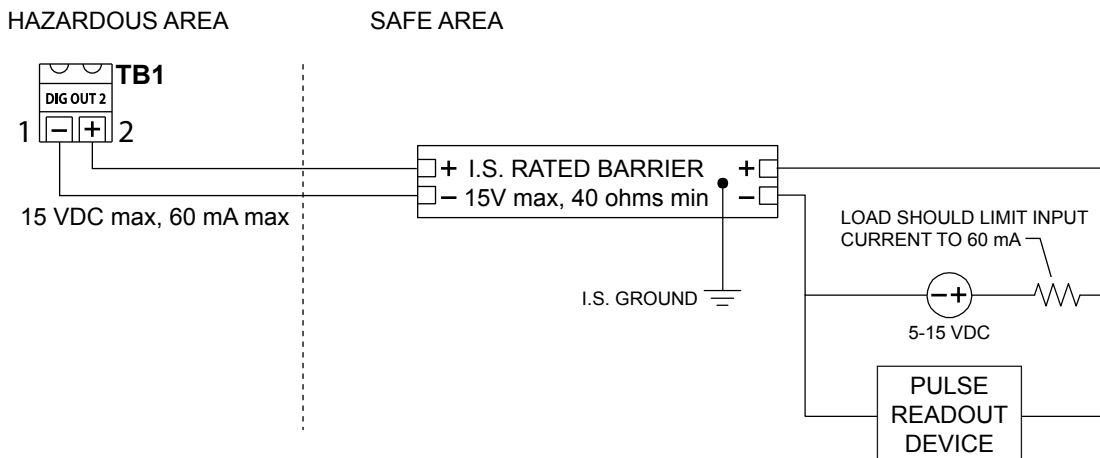

Figure 2.17—Pulse output wiring diagram for sending a secondary output to a pulse readout device simultaneously when the primary output is sent to the solenoid

Important: Before operating the controller for the first time, carefully review Sections 3 and 4 and configure the controller using the keys on the front panel.

Section 3—Operating the Controller

Front Panel

The front panel of the controller contains a Liquid Crystal Display (LCD) with a dual readout and a 6-button keypad for configuring the controller and retrieving data. During operation, the LCD displays the sample count for the current sampling period, as shown in Figure 3.1.

From the front keypad, the operator can change the operating mode, stop a sampling period, start a sampling period, change the sampling configuration settings, initiate a test of the sampling process, and display performance and job status indicators on demand.

This section describes each of these functions except for changing configuration settings. See Section 4, [page 23](#), for configuration instructions.



Figure 3.1—Liquid crystal display and keypad

Keypad Overview

Before programming or operating the sampler for the first time, review this section to familiarize yourself with the functions of each key.

- **MODE**—allows the operator to manually control the start and stop of a sampling period.
- **RESET**—starts a new sampling period using the settings last configured. This function is enabled only when the controller is in “Stop” mode.
- **SAMPLE SETUP**—provides access to configurable settings for controlling the sampling process (see Section 4, [page 23](#), for step-by-step configuration instructions)

- LEFT ARROW/DISPLAY—during normal operation, initiates the scrolling display of status parameters and volumes (see Table 3.1, [page 21](#), for details); during configuration, allows user to select a digit to be changed.
- UP ARROW/TEST—during normal operation, initiates a test of the sampling process; during configuration, increments the value of a selected digit.
- ENTER/SAVE—during configuration, saves each setting entered and advances the display to the next required configurable parameter

Common Keypad Functions

The following information explains how to perform some common tasks with the controller keypad. For step by step instructions for configuring a sampling job, see Section 4. [page 23](#), or refer to the quick reference laminated card inside the controller enclosure.

Stop a Sampling Period

To terminate a sampling period, press MODE and press UP ARROW/TEST to navigate to “Stop” mode. Then press ENTER.

Start a Sampling Period

To initiate a new sampling period, press MODE and press UP ARROW/TEST to navigate to “Start” mode. Then press ENTER.

Alternatively, if the controller is in “Stop” mode, press RESET to start a new sampling period using the settings last configured. Pressing RESET automatically changes the mode to “Start.” (If the controller is set to a mode other than “Stop” before pressing RESET, a new sampling period will not be created. In this case, RESET will have no effect on the sampling job.)

Pause and Resume Sampling Without Starting a New Sampling Period

To resume sampling after putting the controller in “Stop” mode without zeroing the sample count, press MODE, press UP ARROW/TEST to select “Continue” and press ENTER. This is ideal for pausing the sampling process just long enough to change the frequency or volume setting (for example, to expedite completion of the sampling period).

Display Status Indicators On Demand

During normal operation, press UP ARROW/TEST to initiate a scrolling display of status parameters and volumes (see Table 3.1, [page 21](#), for details). After several seconds, the display will revert back to the normal operating screen.

Test the Controller

During normal operation, press UP ARROW/TEST to initiate a test of the sampling configuration.

On-Demand Display of Status Indicators and Volumes

During normal operation, the operator can initiate a scrolling display of performance and job status indicators by pressing LEFT ARROW/DISPLAY. The parameters displayed can vary, depending on the type of sampling programmed. Table 3.1, [page 21](#), lists all supported indicators, and indicates which parameters are available for each sampling configuration. The last two columns of the table show the content of top and bottom readouts associated with each parameter.

Table 3.1—Performance and Job Status Indicators

Indicator	Sampling Function						Text Displayed in Readouts	
	Time/ Batch	Volume: Pulse EFM	Volume: Pulse Input	Volume: TFM	Continuous	Test		
RUN TIME	Yes	Yes	Yes	Yes	Yes	Yes	TOP BOTTOM	0.000 RUN TIME - DAYS
PERCENT DONE	Yes	Yes	Yes	Yes	No	No	TOP BOTTOM	0.00 PERCENT DONE
FLOW RATE	No	No	Yes	Yes	No	No	TOP BOTTOM	0.00 (GAL) FLOW RATE (/SEC)
TOTAL VOLUME	No	No	Yes	Yes	No	No	TOP BOTTOM	0.000 (GAL) TOTAL VOLUME
GRAND TOTAL VOLUME	No	No	Yes	Yes	No	No	TOP BOTTOM	0.00 (GAL) GRAND TOTAL
SYSTEM VOLTAGE	Yes	Yes	Yes	Yes	Yes	Yes	TOP BOTTOM	6.656 SYSTEM VOLTAGE
BATTERY LEFT (%)	Yes	Yes	Yes	Yes	Yes	Yes	TOP BOTTOM	100.00 BATTERY LEFT - %
SAMPLER STATUS	Yes	Yes	Yes	Yes	Yes	Yes	TOP BOTTOM	RUNNING SAMPLER STATUS
FIRMWARE VERSION	Yes	Yes	Yes	Yes	Yes	Yes	TOP BOTTOM	2.00 TRUE CUT 2000
SAMPLES TAKEN	Yes	Yes	Yes	Yes	Yes	Yes	TOP BOTTOM	0 SAMPLE TAKEN

Run Time

Run Time displays the length of time (number of days) the sampler has been in operation during the existing sampling period. The run time value is zeroed each time a new sampling period is started.

Percent Done

Percent Done displays the percentage of a sampling job that is completed at any point in time. This indicator is not available for Continuous Time sampling since the total samples required is not entered or calculated.

Flow Rate

Flow Rate displays the rate of flow sensed by the input device based on the K-factor entered. The controller displays the flow rate in terms of flow per second, per minute, per hour or per day.

Total Volume

Total Volume is the volume of pipe flow sensed by the input device (pulse input or TFM frequency input) during a volume-based sampling period. The controller calculates and displays pipe flow volume totals in gallons, barrels, cubic meters, liters, or standard cubic feet. If a different unit is required, a “none” option is also available in the controller. Volume is updated once per second. Both volume per sampling period (total volume) and total accumulated volume (grand total volume) are stored in the controller.

Total volume is cleared each time a new sampling period is started.

Grand Total Volume

Grand Total Volume is the total accumulated volume of pipe flow. Unlike total volume, which is zeroed each time a new sampling period begins, the grand total volume is zeroed only when the battery is replaced or the volume input is otherwise removed. When power is restored and a new volume-based sampling period is initiated, the grand total volume count restarts.

System Voltage

System Voltage displays the DC voltage generated by either the battery or an external power supply after power is regulated internally.

Battery Left (%)

Battery Left (%) displays an estimate of the percentage of battery life remaining in the lithium battery. This indicator will be displayed only when the lithium battery is used as the primary power supply. When the battery is nearly spent, the bottom readout will display the message “replace battery.”

When the battery has been replaced, it is necessary to reset the battery life counter using the Sampler Setup menu. See [Reset Battery Life \(Lithium-Powered Devices Only\)](#), [Battery Life Reset \(Lithium-Powered Devices Only\)](#), page 27, for details.

Sampler Status

Sampler Status indicates the status of sampler operation. When the sampler is in operation (controller is placed in “Start” or “Continue” mode), the status will display as “Running.” When performing a test of the sampler (UP ARROW/TEST), status will display as “Test.” When sampling is manually terminated (controller placed in “Stop” mode), status will display as “Stop.” When a sample period has ended, status will display as “Done.”

Firmware Version

It may be helpful to confirm the firmware version in the event that a question arises about the operation of the device. Over time, multiple firmware versions may be released with varying functionality.

Section 4—Programming the Controller

Before programming the controller, review Section 3, [page 19](#), to become familiar with the controller keys and their functions.

During configuration, the LCD guides the user through menus and settings for customizing the sampling operation. When navigating menus, the top readout identifies available menus and the bottom readout provides quick tips for navigating menus with the arrow keys. Once a menu is selected, the bottom readout identifies each configurable parameter by name and the top readout displays the current value or setting.

Step-by-step sampling configuration instructions are also printed on a quick reference laminated card provided inside the controller enclosure.

Power Supply Selection

Before operating the True Cut 2000 controller for the first time, configure the power supply using the front panel keypad.

1. Press **SAMPLE SETUP** and then press **UP ARROW/TEST** to select “P Supply.” Press **ENTER**.
2. “Lith Batt” appears as the first selection. If using a lithium battery, press **ENTER**. Otherwise, proceed to step 3. If lithium is selected, a Reset Battery Life menu option will appear, and the top readout will display “Yes.”
 - a. To reset the battery life counter to zero (recommended for new batteries only), press **ENTER**.
 - b. To exit the menu without resetting the battery life counter, press **UP ARROW/TEST** to change the top readout display to “No”, then press **ENTER**.
3. Press **UP ARROW/TEST** to select a different power supply.
For a rechargeable lead acid battery, advance the menu to “Solar” and press **ENTER**.
For external power, advance the menu to “Other” and press **ENTER**.

Time-Based Sampling

Use the following procedures to configure the sampler controller for time-based sampling.

To pause sampling before the sampling period is completed, press **MODE**, press **UP ARROW/TEST** to change the mode to “Stop” and press **ENTER** to stop the sampling process. Make any changes necessary (for example, a user may wish to change the frequency or volume setting to expedite completion of the job) and press **ENTER**.

To resume sampling without zeroing the sample count, press **MODE**, press **UP ARROW/TEST** to select “Continue” and press **ENTER**. The sampler will resume operation and the previously saved sample count will begin to increment using the new settings to control the sampling process.

Batch/Time Sampling

1. Press **SAMPLE SETUP** and then press **UP ARROW/TEST** to select “Batch” or “Time.” Press **ENTER**.
 - a. If “Batch” is selected, enter the “Sample Period” (number of days allowed for sample collection) by pressing **UP ARROW/TEST**. Press **ENTER**.

- b. If “Time” is selected, enter the “Sample Frequency” in seconds using the **LEFT ARROW/DISPLAY** key to select a digit and the **UP ARROW/TEST** key to change the digit’s value. Values from 5 to 65535 may be entered. Press **ENTER**.
3. Enter the “Bottle Size” by pressing **LEFT ARROW/DISPLAY** to select a digit and **UP ARROW/TEST** to change the digit’s value. Values from 25 to 10000 may be entered. Press **ENTER**. (The value entered can reflect any unit the user desires.)
4. Enter the “Sample Size” by pressing **LEFT ARROW/DISPLAY** to select a digit and **UP ARROW/TEST** to change the digit’s value. Values from 0.05 to 10 may be entered. Press **ENTER**. (The value entered can reflect any unit the user desires.)
5. Change the digital output setting if required by pressing **UP ARROW/TEST** to display any of four digital output options:
 - DO 1 = internal solenoid (default)
 - DO 2 = external solenoid or pulse output
 - DO 1 and 2 = simultaneous output to an internal solenoid and an external solenoid or pulse output
 - DO 1 - - 2 = alternates output from one solenoid to a second solenoid to allow sampling to be automatically redirected to a second receiver when the first receiver is filled.

Important: When the DO 1 - - 2 output option is enabled, outputs will continue to switch between the two solenoids as one receiver is filled until the sampling is manually terminated.

6. When the desired digital output setting is displayed, press **ENTER**.
7. Press **RESET** to begin sampling. When the sampling job is completed, the final sample count will be displayed in the top readout and the words “Sampling Done” will appear in the bottom readout.

Continuous Time Sampling

1. Press **SAMPLE SETUP** and press **UP ARROW/TEST** to select “Cont.” Press **ENTER**.
2. Enter the “Sample Frequency” in seconds by pressing **UP ARROW/TEST**. Values from 5 to 65535 may be entered. Press **ENTER**.
3. Press **RESET** to begin sampling. Sampling will continue until the sample period is manually terminated.

Important: The user must **MANUALLY** terminate the sampling period when continuous time sampling is configured. To minimize the risk for overflow, continuous time sampling is not recommended for use in filling portable receivers. This configuration is typically used when collecting sampled product in tanks or other large storage devices.

Volume-Based Sampling

Use the following procedures to configure the sampler controller for volume-based sampling.

To pause sampling before the sampling period is completed, press **MODE**, press **UP ARROW/TEST** to change the mode to “Stop” and press **ENTER** to stop the sampling process. Make any changes necessary (for example, a user may wish to change the frequency or volume setting to expedite completion of the job) and press **ENTER**.

To resume sampling without zeroing the sample count, press **MODE**, press **UP ARROW/TEST** to select “Continue” and press **ENTER**. The sampler will resume operation and the previously saved sample count will begin to increment using the new settings to control the sampling process.

Pulse Input

1. Press **SAMPLE SETUP** and press **UP ARROW/TEST** to select “Vol Accu.” Press **ENTER**.
2. For “Input Sensitivity,” press **UP ARROW/TEST** to select “Pulse In.” Press **ENTER**.
3. Press **UP ARROW/TEST** to select “Pulse In Type” (“P Freq” or “EFM Set”). Press **ENTER**. If “EFM Set” is selected, skip to step 8.
4. Enter “K Factor” by pressing **LEFT ARROW/DISPLAY** to select a digit and **UP ARROW/TEST** to change the digit’s value. Press **ENTER**.
5. Enter the flow volume unit (GAL, BBL, M3, LIT, CF, NONE) by pressing **UP ARROW/TEST**. Press **ENTER**.
6. Enter the flow rate unit (SEC, MIN, HR, DAY) by pressing **UP ARROW/TEST**. Press **ENTER**.
7. Enter “Volume Per Sample” by pressing **LEFT ARROW/DISPLAY** to select a digit and **UP ARROW/TEST** to change the digit’s value. Values from 0.05 to 10 may be entered. Press **ENTER**.
8. Select “Bottle Size” by pressing **LEFT ARROW/DISPLAY** to select a digit and **UP ARROW/TEST** to change the digit’s value. Values from 25 to 10000 may be entered. Press **ENTER**. (The value entered can reflect any unit the user desires.)
9. Select “Sample Size” by pressing **LEFT ARROW/DISPLAY** to select a digit and **UP ARROW/TEST** to change the digit’s value. Values from 0.05 to 10 may be entered. Press **ENTER**. (The value entered can reflect any unit the user desires.)
10. Change the digital output setting if required by pressing **UP ARROW/TEST** to display any of four digital output options:
 - DO 1 = internal solenoid (default)
 - DO 2 = external solenoid or pulse output
 - DO 1 and 2 = simultaneous output to an internal solenoid and an external solenoid or pulse output
 - DO 1 - - 2 = alternates output from one solenoid to a second solenoid to allow sampling to be automatically redirected to a second receiver when the first receiver is filled.

Important: When the DO 1 - - 2 output option is enabled, outputs will continue to switch between the two solenoids as one receiver is filled until the sampling is manually terminated.

11. When the desired digital output setting is displayed, press **ENTER**.
12. Press **RESET** to begin sampling. When the sampling job is completed, the final sample count will be displayed in the top readout and the words “Sampling Done” will appear in the bottom readout.

Volume Sampling (TFM Input)

1. Press **SAMPLE SETUP** and press **UP ARROW/TEST** to select “Vol Accu.” Press **ENTER**.
2. For “Input Sensitivity,” press **UP ARROW/TEST** to select ‘Lo’, ‘Med’, ‘Hi’ or ‘Highest.’ Press **ENTER**.

3. Enter “K Factor” by pressing **LEFT ARROW/DISPLAY** to select a digit and **UP ARROW/TEST** to change the digit’s value. Press **ENTER**.
4. Press **UP ARROW/TEST** to select flow unit (GAL, BBL, M3, LIT, CF, NONE). Press **ENTER**.
5. Press **UP ARROW/TEST** to select rate unit (SEC,MIN, HR, DAY). Press **ENTER**.
6. Enter ‘Volume Per Sample’ by pressing **LEFT ARROW/DISPLAY** to select a digit and **UP ARROW/TEST** to change the digit’s value. Values from 0.05 to 10 may be entered. Press **ENTER**.
7. Select “Bottle Size” by pressing **LEFT ARROW/DISPLAY** to select a digit and **UP ARROW/TEST** to change the digit’s value. Values from 25 to 10000 may be entered. Press **ENTER**. (The value entered can reflect any unit the user desires.)
8. Select “Sample Size” by pressing **LEFT ARROW/DISPLAY** to select a digit and **UP ARROW/TEST** to change the digit’s value. Values from 0.05 to 10 may be entered. Press **ENTER**. (The value entered can reflect any unit the user desires.)
9. Change the digital output setting if required by pressing **UP ARROW/TEST** to display any of four digital output options:
 - DO 1 = internal solenoid (default)
 - DO 2 = external solenoid or pulse output
 - DO 1 and 2 = simultaneous output to an internal solenoid and an external solenoid or pulse output
 - DO 1 - - 2 = alternates output from one solenoid to a second solenoid to allow sampling to be automatically redirected to a second receiver when the first receiver is filled.

Important: When the DO 1 - - 2 output option is enabled, outputs will continue to switch between the two solenoids as one receiver is filled until the sampling is manually terminated.

10. When the desired digital output setting is displayed, press **ENTER**.
11. Press **RESET** to begin sampling. When the sampling job is completed, the final sample count will be displayed in the top readout and the words “Sampling Done” will appear in the bottom readout.

Sampler Test

The TEST key on the keypad allows a user to test sampler function by activating the solenoid for a short period. The TEST menu can also be accessed from the SAMPLE SETUP menu.

1. Press **UP ARROW/TEST**. “Run Test” will appear in the bottom readout. By default, the setting in the top readout is YES.
2. To proceed, press **ENTER**. The “Number of Test Samples” parameter is displayed.
3. Enter the desired number of test samples by pressing **LEFT ARROW/DISPLAY** to select a digit and **UP ARROW/TEST** to change the digit’s value. Values from 1 to 20 may be entered. Press **ENTER**.
4. Change the digital output setting if required by pressing **UP ARROW/TEST** the digital output in use:
 - DO 1 = internal solenoid (default)
 - DO 2 = external solenoid or pulse output
5. Press **ENTER**. The test should start automatically and a sample count should appear on the display. By default, the test function will activate the solenoid every 5 seconds until the sample count equals the configured number of test samples.

6. When the sampling job is completed, the final sample count will be displayed in the top readout and the words “Sampling Done” will appear in the bottom readout.

Battery Life Reset (Lithium-Powered Devices Only)

A built-in battery life counter can help the users of lithium battery-powered devices to anticipate when the battery pack is nearly spent and should be replaced. Immediately after replacing a battery pack, reset the battery life counter using the following procedure.

1. Press **SAMPLE SETUP** and then press **UP ARROW/TEST** to select “P SUPPLY.” Press **ENTER**.
2. “Lith Batt” will appear as the first selection. Press **UP ARROW/TEST** to select YES in the battery reset menu. Press **ENTER** to reset the battery life to 100%. (To bypass the battery reset menu without resetting battery life, press **UP ARROW/TEST** to change the top readout display to “No,” then press **ENTER**.)

Keypad Security

The True Cut 2000 Sampler Controller supports two levels of keypad security.

The Basic security setting allows an administrator to restrict access to the Sample Setup key to prevent unauthorized users from changing configuration settings.

The Advanced security setting allows an administrator to restrict access to all keys except the LEFT ARROW/DISPLAY key and the ENTER/SAVE key. With this setting enabled, unauthorized users cannot change configuration settings, mode of operation, or start a new sampling period.

Using the steps below, the administrator can disable security (providing full access to the keypad controls to all users), enable basic security, or enable advanced security.

Disable Security

1. Press **SAMPLE SETUP**, and select “Security” by pressing **UP ARROW/TEST**. Press **ENTER**.
2. Select “No” for no security by pressing **UP ARROW/TEST**. Press **ENTER**.
3. Test to see if all buttons can be accessed.

Basic Security

1. Press **SAMPLE SETUP**, and select “Security” by pressing **UP ARROW/TEST**. Press **ENTER**.
2. Select “Basic” by pressing **UP ARROW/TEST**. Press **ENTER**.
3. Enter “Security Code” by pressing **LEFT ARROW/DISPLAY** to select a digit and **UP ARROW/TEST** to change the digit’s value. Press **ENTER**. The default access code is 0000.
 - a. Record the new security code for future reference.
 - b. To restore access to security settings in the event of a lost access code, see [Security Bypass, page 28](#).
4. Press **SAMPLE SETUP**. If it is locked and cannot be accessed, the security control is enabled.

Advanced Security

1. Press **SAMPLE SETUP**, and select “Security” by pressing **UP ARROW/TEST**. Press **ENTER**.
2. Select “Advanced” by pressing **UP ARROW/TEST**. Press **ENTER**.
3. Enter “Security Code” by pressing **LEFT ARROW/DISPLAY** to select a four-digit code and **UP ARROW/TEST** to change the digit’s value. Press **ENTER**. The default access code is 0000.
 - a. Record the new security code for future reference.
 - b. To restore access to security settings in the event of a lost access code, see [Security Bypass](#).
4. Press each key to test the security control. Only **LEFT ARROW/DISPLAY** and **ENTER** should be accessible.

Security Bypass

Have you misplaced your security password? Cameron gives you the ability to restore access quickly and easily with a one-time bypass code.

Important: To obtain a bypass code, you must provide Cameron with a number generated using the following procedure. Before starting this process, make sure you have paper and a pen to record the number that appears on the instrument display. The number will remain on the display only for a few seconds.

To obtain this bypass code, perform the following steps:

1. Record the serial number of your True Cut 2000 instrument (shown on the serial tag attached to the outside of the enclosure). You will be asked for this information later in the procedure.
2. Using the True Cut 2000 keypad, press and hold the **LEFT ARROW** and **ENTER** keys simultaneously for 3 seconds, then release. The word “bYPASS” will appear in the bottom display, and a number will appear in the top display.
3. Record this number.
4. Call a Cameron (Measurement Systems Division) sales representative, and give him/her the number from the display and the serial number of the True Cut 2000 instrument. After verifying your identity, he/she will provide you with a one-time bypass code.
5. Enter the bypass code in place of your password at the security code prompt the next time you use the keypad.

Section 5—Spare Parts

The following parts are recommended for use with the True Cut 2000 Sampler Controller.



WARNING: EXPLOSION HAZARD – Substitution of components may impair suitability for Class I, Division 1. Use of spare parts other than those identified by Cameron International Corporation voids hazardous area certification. Cameron bears no legal responsibility for the performance of a product that has been serviced or repaired with parts that are not authorized by Cameron.

Table 5.1—Spare Parts

Part Number	Description
2295850-01	Circuit Board Assembly
9A-70099001	Battery Assembly - Lithium Pack, 7.2 VDC (2D Cell)
2296472-01	Battery Assembly - Lead Acid, 6 VDC
2296473-01	Assembly, Solar Panel with Connector (for use with lead acid battery pack Part No. 2296472-01)
2296735-01	Standard Solenoid with Diode Assembly, 100 PSI (plastic)
2296736-01	Premium Solenoid with Diode Assembly, 120 PSI (stainless steel)
9A-70165002	User Manual, True Cut 2000 Sampler Controller

Table 5.2—Optional Accessories

Part Number	Description
9A-50132600271	Direct Mount Solar Installation Kit (includes solar panel, mounting hardware, lead acid battery pack and cable/connector)
2296685-01	Remote Mount Solar Installation Kit (includes solar panel, mounting hardware, lead acid battery pack and cable/connector)

Appendix A—Lithium Battery Information

Lithium Battery Disposal

Once a lithium battery is removed from a device and/or is destined for disposal, it is classified as solid waste under EPA guidelines. Depleted lithium batteries are also considered to be hazardous waste because they meet the definition of Reactivity, as per 40 CFR 261.23(a)(2), (3) and (5). This document describes how the lithium reacts violently with water, forms potentially explosive mixtures with water, and when exposed to certain pH conditions, generates toxic cyanide or sulfide gases.

Federal law requires that depleted lithium batteries be sent to a fully permitted Treatment, Storage and Disposal Facility (TSDF) or to a permitted recycling/reclamation facility.

Important: Do not ship lithium batteries to Cameron's Measurement Systems Division. Cameron facilities are not permitted recycling/reclamation facilities.

CAUTION: Profiling and waste characterization procedures must be followed prior to shipping a lithium battery to a disposal site. It is the shipper's responsibility to comply with all applicable federal transportation regulations (see below).

Transportation Information

WARNING: The True Cut Sampler Controller may contain lithium batteries. The internal component (thionyl chloride) is hazardous under the criteria of the Federal OSHA Hazard Communication Standard 29 CFR 1920.1200. Before shipping a lithium battery or equipment containing a lithium battery, verify that the packaging and labeling conforms with the latest version of all applicable regulations.

The transport of the lithium batteries is regulated by the United Nations, "Model Regulations on Transport of Dangerous Goods," (special provisions 188, 230, and 310), latest revision.

Within the US the lithium batteries and cells are subject to shipping requirements under Part 49 of the Code of Federal Regulations (49 CFR, Parts 171, 172, 173, and 175) of the US Hazardous Materials Regulations (HMR), latest revision.

Shipping of lithium batteries in aircraft is regulated by the International Civil Aviation Organization (ICAO) and the International Air Transport Association (IATA) requirements in Special Provisions A45, A88 and A99, latest revision.

Shipping of lithium batteries on sea is regulated the International Maritime Dangerous Goods (IMDG) requirements in special provisions 188, 230 and 310, latest revision.

Shipping of lithium batteries on road and rail is regulated by requirements in special provisions 188, 230 and 310, latest revision.

Appendix B—Communications Protocol

Firmware Version: 2.00

Register Table Version: 7

Introduction

The communications protocol for the True Cut 2000 is in accordance with Modicon, Inc. RTU Mode Modbus® as described in Modicon Modbus Protocol Reference Guide, PI-MBUS-300 Rev. J, June 1996. All registers are implemented as 4X or holding registers. Reading of registers is implemented via function code 03H (Read Holding Registers). Writing to registers is implemented via function code 10H (Preset Multiple Registers).

Supported Commands

The Modbus® functions supported by the True Cut 2000 are as follows:

<i>Function Code (Hex)</i>	<i>Description</i>
03	Read Holding Registers
10	Preset Multiple Registers

For the read holding and preset multiple registers, the instrument supports the full 250 bytes of data in a message. This corresponds to 125 registers in 16-bit holding register size.

Data Types

Various data types are implemented in the True Cut 2000. The following table lists the formats and the numbers of bytes and registers associated with each type

<i>Data Type</i>	<i>Byte Count</i>	<i>Register Count</i>
Floating Point (FP)	4	2
Unsigned Word (U16)	2	1

The word ordering for multiple register data types, such as floating-point numbers or long integers, is for the most significant word to appear first in the message.

The Unsigned Word (U16) type is used for 16-bit integers and fits into one register.

Registers

Each register has an Access type: read-only or read-write, as described below.

<i>Access Type</i>	<i>Description</i>
Read Only (RO)	Register can only be read
Read/Write (R/W)	Register can be read and written

The registers are grouped into Modbus® map blocks according to function. The True Cut 2000 contains the following map functions.

Map	Starting Register
Communications Configuration	1100
True Cut 2000 Configuration	1700
Holding Registers	8762

Important: All registers cited in this document refer to the address of the register that appears in the actual Modbus® message. For example, register 8000 has an address of 0x1F40 hexadecimal in the message.

Communications Configuration

Register (Decimal)	Register (Hex)	Description	Data Type	Access	Default
1100	44C	Port 1 – Port Usage 0 – Slave	U16	R/W	0
1101	44D	Port 1 Slave Address [1 to 65535, excluding 252 and 64764]	U16	R/W	1
1102	44E	Port 1 – Baud Rate 3 – 2400 4 – 4800 5 – 9600 6 – 19200 7 – 38400	U16	R/W	5
1103	44F	Port 1 – Bus Delay mS of delay before transmitting data	U16	R/W	10
1104	450	Port 1 – Bus Timeout mS of delay before resetting communications	U16	R/W	50
1105	451	Port 2 – Port Usage 0 – Slave	U16	R/W	0
1106	452	Port 2 Slave Address [1 to 65535, excluding 252 and 64764]	U16	R/W	1
1107	453	Port 2 – Baud Rate 3 – 2400 4 – 4800 5 – 9600 6 – 19200 7 – 38400	U16	R/W	5
1108	454	Port 2 – Bus Delay mS of delay before transmitting data	U16	R/W	10
1109	455	Port 2 – Bus Timeout mS of delay before resetting communications	U16	R/W	50

True Cut 2000 Configuration

Register (Decimal)	Register (Hex)	Description	Data Type	Access	Default	Min/Max
1700	6A4	Power Supply 0 – Lithium 1 – Solar 2 – Other (Ext. Power)	U16	R/W	0 – Lithium	—
1701	6A5	Sampler Function Type 0 – Batch 1 – Time 2 – Volume 3 – Continuous 4 – Test 5 – Battery Reset 6 – Keypad Security	U16	R/W	0 – Batch	—
1702	6A6	Function Mode 0 – Stop 1 – Start 2 – Continue	U16	R/W	0 – Stop	—
1703	6A7	Volume Sampling Type 0 – Lo 1 – Med 2 – High 3 – Highest 4 – Pulse Input	U16	R/W	4 – Pulse In	—
1704	6A8	Pulse Input Sampling Type 0 – EFM Pulse In 1 – Pulse In Frequency	U16	R/W	0 – EFM Pulse In	—
1705	6A9	(Reserved)				—
1706	6AA	Keypad Security Type 0 – None 1 – Basic 2 – Advanced	U16	R/W	0 – None	—
1707	6AB	Digital Output Type DO1, internal DO2, external or pulse output DO 1 and 2, simultaneous DO 1 and 2, alternating	U16	R/W	DO1 (internal)	—
1708	6AC	(Reserved)				—
1709	6AD	Test Sampling Max Count	U16	R/W	10	1 / 20
1710	6AE	Sample Period (Days) 0 – 1 Day 1 – 2 Days 2 – 3 Days 3 – 4 Days 4 – 5 Days 5 – 6 Days 6 – 7 Days 7 – 10 Days 8 – 14 Days	U16	R/W	13 – 30 Days	—

Register (Decimal)	Register (Hex)	Description	Data Type	Access	Default	Min/Max
1710 (continued)	6AE	Sample Period (Days) 9 – 15 Days 10 – 21 Days 11 – 25 Days 12 – 28 Days 13 – 30 Days 14 – 31 Days	U16	R/W	13 – 30 Days	—
1711	6AF	Sample Frequency (Seconds)	U16	R/W	5	5 / 65535
1712	6B0	Volume Flow Unit (Scale) 0 – No Unit (1.000000000000) 1 – GAL (1.000000000000) 2 – BBL (0.023809523810) 3 – M3 (0.003785411780) 4 – LIT (3.785411784000) 5 – CF (0.133680555560)	U16	R/W	1 – GAL	—
1713	6B1	Volume Flow Rate Unit – Time Base 0 – Second 1 – Minute 2 – Hour 3 – Day	U16	R/W	0 – Sec	—
1714	6B2	Sample Bottle Size	FP	R/W	300.00	25 / 10000
1716	6B4	Sample Grab Size	FP	R/W	0.5	0.05 / 10
1718	6B6	K-Factor	FP	R/W	900.00	—
1720	6B8	Volume Per Sample	FP	R/W	5.00	0.05 / 100
1722	6BA	Battery Life Percent (Resettable)	FP	R/W	100.00	—
1724	6BC	Grand Total Sample Count (Resettable)	FP	R/W	0.00	—

Holding Registers

Register (Decimal)	Register (Hex)	Description	Data Type	Access
8762	381	Current Sample Count	FP	RO
8764	382	Current Sampling Time (Second)	FP	RO
8766	383	Current Sampling Time (Day)	FP	RO
8768	384	Estimated Battery Life	FP	RO
8770	385	Maximum Sample Per Bottle	FP	RO
8772	386	Sample Bottle Fill Percent	FP	RO
8774	387	Sample Frequency	FP	RO
8776	388	Grand Total Volume	FP	RO
8778	389	Current Total Volume	FP	RO
8780	390	Flow Rate	FP	RO

Register (Decimal)	Register (Hex)	Description	Data Type	Access
8782	391	Input Frequency	FP	RO
8784	392	K-Factor	FP	RO
8786	393	Sampler Status 1 – Running 2 – Test 3 – Stop 4 – Done	FP	RO
8788	394	Test Sample Count	FP	RO

WARRANTY - LIMITATION OF LIABILITY: Seller warrants only title to the products, software, supplies and materials and that, except as to software, the same are free from defects in workmanship and materials for a period of one (1) year from the date of delivery. Seller does not warrant that software is free from error or that software will run in an uninterrupted fashion. Seller provides all software "as is". THERE ARE NO WARRANTIES, EXPRESS OR IMPLIED, OF MERCHANTABILITY, FITNESS OR OTHERWISE WHICH EXTEND BEYOND THOSE STATED IN THE IMMEDIATELY PRECEDING SENTENCE. Seller's liability and Buyer's exclusive remedy in any case of action (whether in contract, tort, breach of warranty or otherwise) arising out of the sale or use of any products, software, supplies, or materials is expressly limited to the replacement of such products, software, supplies, or materials on their return to Seller or, at Seller's option, to the allowance to the customer of credit for the cost of such items. In no event shall Seller be liable for special, incidental, indirect, punitive or consequential damages. Seller does not warrant in any way products, software, supplies and materials not manufactured by Seller, and such will be sold only with the warranties that are given by the manufacturer thereof. Seller will pass only through to its purchaser of such items the warranty granted to it by the manufacturer.

MEASUREMENT SYSTEMS

HOUSTON
HEAD OFFICE | **281.582.9500**

NORTH
AMERICA | **1.800.654.3760**
ms-us@c-a-m.com

ASIA
PACIFIC | **+603.5569.0501**
ms-kl@c-a-m.com

EUROPE,
MIDDLE EAST
& AFRICA | **+44.1243.826741**
ms-uk@c-a-m.com

USA • CANADA • UK • CHINA • UAE • ALGERIA • MALAYSIA • INDIA • RUSSIA

www.c-a-m.com/flo

