

REVISIONS				
REV	DESCRIPTION	BY	ECO	DATE
E	UPDATED DRAWING	FJM	0100335	07/24/14

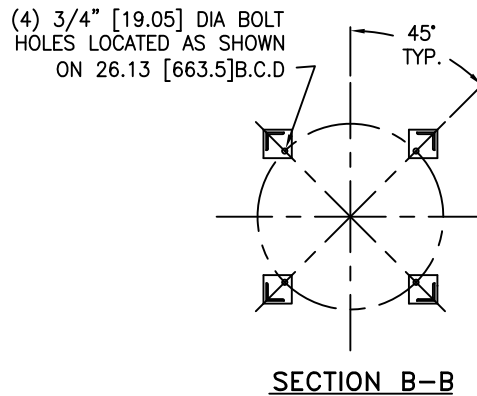

(4) 3/4" [19.05] DIA BOLT HOLES LOCATED AS SHOWN ON 26.13 [663.5] B.C.D

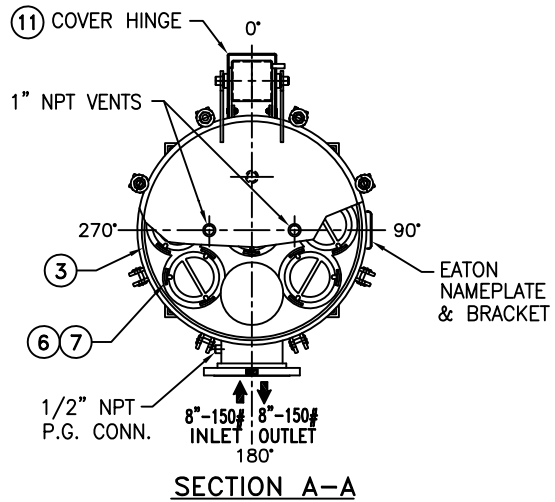
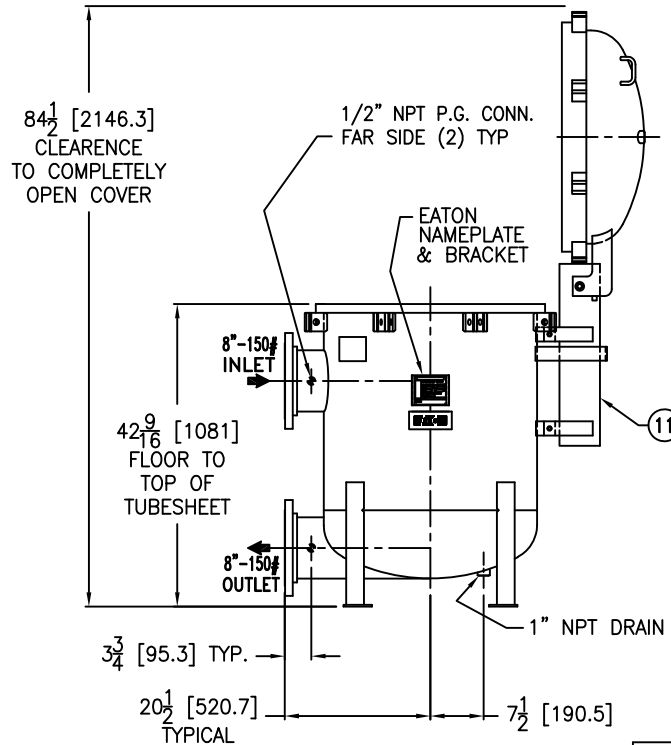
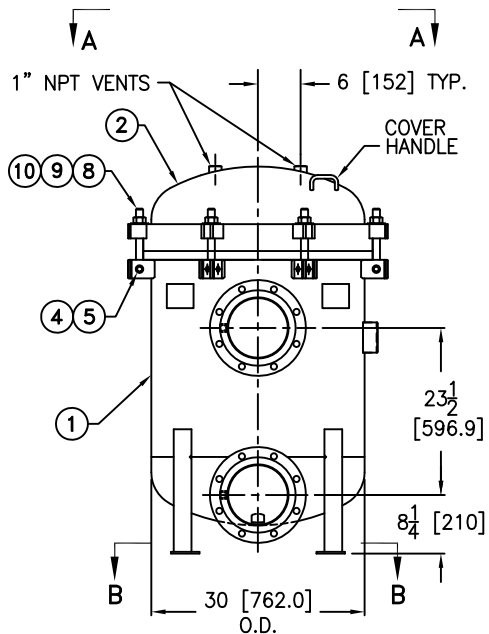

ITEM	PART NAME	MATERIAL
1	BODY	SA240-316/316L
2	COVER	SA240-316/316L
3	O-RING P/N 2375037193	BUNA-N
4	PIN	SA193 B7 ZINC PL
5	SNAP RING	STEEL ZINC PL
6	RESTRAINER BASKET P/N L0001753	316 SS
7	FILTER BAG RETAINER	316 SS
8	EYE BOLT	SA354 BD ZINC PL
9	HEX NUT	SA194 2H ZINC PL
10	WASHER	STEEL ZINC PL
11	SPRING ASSISTED MECHANISM	STAINLESS STEEL

**NOTES:**

- UNITS ARE TO BE DESIGNED, FABRICATED & "U" STAMPED IN ACCORDANCE WITH ASME SECT. VIII, DIV. 1 BOILER & PRESSURE VESSEL CODE, IN COMPLIANCE TO LATEST ADDENDA.
- INLET / OUTLET FLANGE CONNECTIONS PER ANSI B 16.5.
- DESIGN PRESSURE: 150 PSI (MAWP)  
DESIGN TEMPERATURE 250° F.  
MDMT - -20° F @ 150 PSI.
- DIMENSIONS SHOWN IN [ ] ARE IN MILLIMETERS AND FOR REFERENCE ONLY. ACCEPTANCE OF THIS PART WILL BE BASED ON "INCH" UNITS & TOLERANCES ONLY.
- ALL BOLT HOLES ARE TO STRADDLE NATURAL CENTERLINES.
- APPROX. WEIGHT (DRY) 1000 LBS. (453.6 kgs.)
- APPROX. SHIPPING WEIGHT 1130 LBS. (512.6 kgs.)

TOLERANCES (UNLESS OTHERWISE SPECIFIED)	
DECIMAL:	.X ± .030 .XX ± .010 .XXX ± .005
FRACTIONAL:	± 1/16
NOZZLE Ø TO FLOOR:	1/8" < 4' > 1/4"
FACE TO FACE:	1/8" < 4' > 1/4"
ANGULAR:	± 1'
FLANGES (H/V):	± 1/2"
VESSEL OVERALL HT:	1"

BOLT HOLES MUST STRADDLE Ø MACHINED PARTS TO BE FREE OF BURRS FOR ADDITIONAL TOLERANCE DETAILS REF. ES-211, ES-222 AND ES-223

REVIEWED FOR CLASSIFICATION PER PR-4

CRITICAL SIGNIFICANT

CUSTOMER INFO	
NAME	
P.O. NO.	
S.O. NO.	
QUANTITY	
PART NO.	F3AV0800001L

DRAWN BY	FJM
SCALE	AS DRAWN
RESTRICTION	RESTRICTED
SHEET	1 OF 1
PROJECTION	THIRD ANGLE

VESSEL CODE: MBF-0802-AB10-080A-UT-11HE-LOOP				
<b>EATON</b>		EATON FILTRATION DESIGN CENTER TINTON FALLS, NEW JERSEY, USA • PORTAGE, MICHIGAN, USA		
TITLE MAXILINE (MBF-0802 HE) FILTER VESSEL 8" 150# RF INLET / TANGENTIAL OUTLET SS-316 W/BUNA O-RING				
DATE	06/16/03	SIZE	A	DWG FILENAME
REV	E	HE0808TSL		

EATON CORPORATION - CONFIDENTIAL AND PROPRIETARY NOTICE TO PERSONS RECEIVING THIS DRAWING AND/OR TECHNICAL INFORMATION THIS DOCUMENT, INCLUDING THE DRAWING AND INFORMATION CONTAINED THEREIN IS CONFIDENTIAL AND IS THE EXCLUSIVE PROPERTY OF EATON AT ANY TIME. BY TAKING THE POSSESSION OF THIS DOCUMENT THE RECIPIENT ACKNOWLEDGES AND AGREES THAT THIS DOCUMENT CANNOT BE USED IN ANY MANNER ADVERSE TO THE INTEREST OF EATON AND THAT NO PORTION OF THIS DRAWING MAY BE COPIED OR OTHERWISE REPRODUCED WITHOUT THE PRIOR WRITTEN CONSENT OF EATON. IN THE CASE OF CONFLICT CONTRACTUAL PROVISIONS, THIS NOTICE SHALL GOVERN THE STATUS OF THIS DOCUMENT.  
2014 EATON CORPORATION - ALL RIGHTS RESERVED.