

# Series EHP 60-90

## DN15 PN700/1400

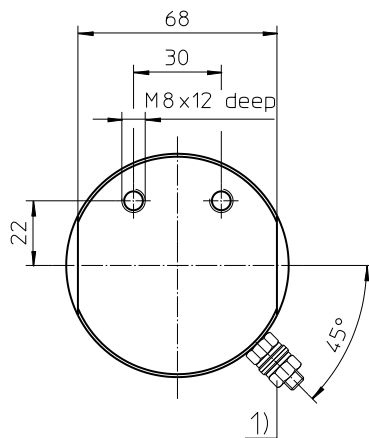
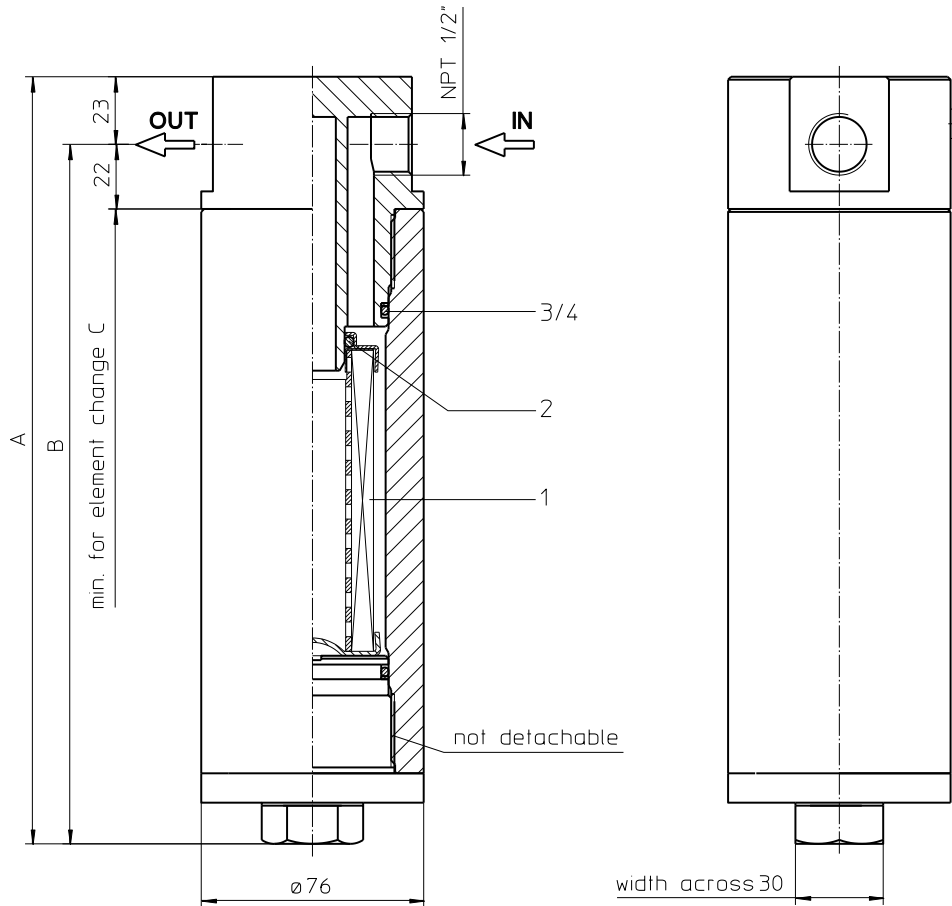

### Dimensions:

type	EHP 60	EHP 90
connection	NPT 1/2"	
A	261	326
B	238	303
C	360	425
weight kg	8,5	9,7
volume tank	0,3 l	0,4 l

- 1) Connection for the potential equalization, only for application in the explosive area.

Dimensions: mm

Designs and performance values are subject to change.



Powering Business Worldwide

# Stainless Steel-Pressure Filter

## Series EHP 60-90

### DN15 PN700/1400

#### Description:

Stainless steel pressure filter series EHP 60-90 have a working pressure up to 700 bar or 1400 bar. Pressure peaks can be absorbed with a sufficient safety margin. The EHP-filter is in-line mounted.

The filter element consists of star-shaped, pleated filter material, which is supported on the inside by a perforated core tube and is bonded to the end caps with a high-quality adhesive. The flow direction is from outside to inside. Filter elements are available down to 5  $\mu\text{m}_{(c)}$ . Finer filtration is available upon request.

Eaton filter elements are known for high intrinsic stability and an excellent filtration capability, a high dirt-retaining capacity and a long service life.

Eaton filter elements are available up to a pressure resistance of 160 bar and a rupture strength of  $\Delta p$  250 bar.

Eaton filter can be used for petroleum-based fluids, HW emulsions, water glycols, most synthetic fluids and lubrication fluids. Consult factory for specific fluid applications.

## 1. Type index:

### 1.1. Complete filter: (ordering example)

**EHP. 90. 10VG. HR. E. P. VA. NPT. 3. VA. 700**

1	2	3	4	5	6	7	8	9	10	11
---	---	---	---	---	---	---	---	---	----	----

- 1 series:**  
EHP = stainless steel-pressure filter
- 2 nominal size:** 60, 90
- 3 filter-material:**  
80G, 40G, 25G , stainless steel wire mesh  
25VG, 16VG, 10VG, 6VG, 3VG microglass
- 4 filter element collapse rating:**  
30 =  $\Delta p$  30 bar  
HR =  $\Delta p$  160 bar (rupture strength  $\Delta p$  250 bar)
- 5 filter element design:**  
E = single-end open
- 6 sealing material:**  
P = Nitrile (NBR)  
V = Viton (FPM)
- 7 filter element specification:**  
- = standard  
VA = stainless steel  
IS06 = for HFC application, see sheet-no. 31601
- 8 process connection:**  
NPT = thread connection according to ANSI B1.20.1
- 9 process connection size:**  
3 = NPT 1/2"
- 10 filter housing specification:**  
VA = stainless steel
- 11 pressure level:**  
700 = max. operating pressure 700 bar  
1400 = max. operating pressure 1400 bar

### 1.2. Filter element: (ordering example)

**01E. 90. 10VG. HR. E. P. VA**

1	2	3	4	5	6	7
---	---	---	---	---	---	---

- 1 series:**  
01E. = filter element according to company standard
- 2 nominal size:** 60, 90
- 3 - 7** see type index-complete filter

## Technical data:

operating temperature:	-10 °C bis +100 °C				
operating medium:	mineral oil, other media on request				
max. operating pressure:	<table border="1"> <tr> <td>700 bar</td> <td>1400 bar</td> </tr> <tr> <td>1000 bar</td> <td>2000 bar</td> </tr> </table>	700 bar	1400 bar	1000 bar	2000 bar
700 bar	1400 bar				
1000 bar	2000 bar				
test pressure:					
process connection:	thread connection				
housing material:	EN10088-3 - 1.4418 + QT900				
sealing material:	Nitrile (NBR) or Viton (FPM), other materials on request				
installation position:	vertical				

Pressure stage 700: Classified under the Pressure Equipment Directive 2014/68/EU for mineral oil (fluid group 2), Article 4, Para. 3.

Pressure stage 1400: Classified under the Pressure Equipment Directive 2014/68/EU for mineral oil category I (Modul A)

Classified under ATEX Directive 2014/34/EU according to specific application (see questionnaire sheet-no. 34279-4).

## Pressure drop flow curves:

### Filter calculation/sizing

The pressure drop of the assembly at a given flow rate Q is the sum of the housing  $\Delta p$  and the element  $\Delta p$  and is calculated as follows:

$$\Delta p_{assembly} = \Delta p_{housing} + \Delta p_{element}$$

$$\Delta p_{housing} = (\text{see } \Delta p = f(Q) - \text{characteristics})$$

$$\Delta p_{element} (mbar) = Q \left( \frac{l}{min} \right) \times \frac{MSK}{10} \left( \frac{mbar}{l/min} \right) \times v \left( \frac{mm^2}{s} \right) \times \frac{\rho}{0,876} \left( \frac{kg}{dm^3} \right)$$

For ease of calculation our Filter Selection tool is available online at [www.eaton.com/hydraulic-filter-evaluation](http://www.eaton.com/hydraulic-filter-evaluation)

### Material gradient coefficients (MSK) for filter elements

The material gradient coefficients in mbar/(l/min) apply to mineral oil (HLP) with a density of 0,876 kg/dm<sup>3</sup> and a kinematic viscosity of 30 mm<sup>2</sup>/s (139 SUS). The pressure drop changes proportionally to the change in kinematic viscosity and density.

EHP	VG					G		
	3VG	6VG	10VG	16VG	25VG	25G	40G	80G
60	5,438	3,775	2,417	2,104	1,438	0,2205	0,1635	0,1526
90	3,271	2,271	1,454	1,266	0,865	0,1333	0,0988	0,0922

### $\Delta p = f(Q)$ – characteristics according to ISO 3968

The pressure drop characteristics apply to mineral oil (HLP) with a density of 0,876 kg/dm<sup>3</sup>. The pressure drop changes proportionally to the density.

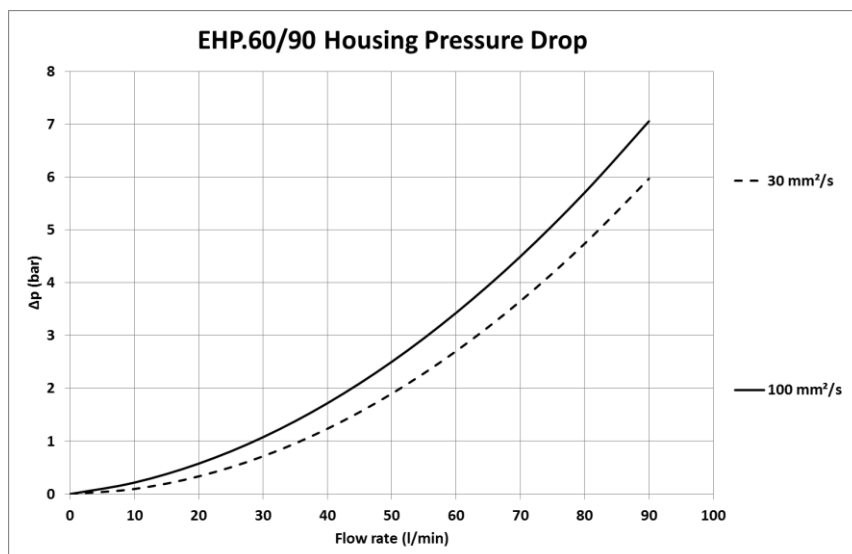

## Symbol:

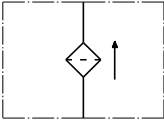

## Spare parts:

item	qty.	designation	dimension		article-no.	
			EHP 60	EHP 90		
1	1	filter element	01E.60....	01E.90...		
2	1	O-ring	22 x 3,5		304341 (NBR)	304392(FPM)
3	1	O-ring	45 x 3		304991 (NBR)	304997 (FPM)
4	1	support ring	52 x 2,6 x 1		311013	

## Test methods:

Filter elements are tested according to the following ISO standards:

ISO 2941	Verification of collapse/burst resistance
ISO 2942	Verification of fabrication integrity
ISO 2943	Verification of material compatibility with fluids
ISO 3723	Method for end load test
ISO 3724	Verification of flow fatigue characteristics
ISO 3968	Evaluation of pressure drop versus flow characteristics
ISO 16889	Multi-pass method for evaluating filtration performance

**North America**  
44 Apple Street  
Tinton Falls, NJ 07724  
Toll Free: 800 656-3344  
(North America only)  
Tel: +1 732 212-4700

**Greater China**  
No. 7, Lane 280,  
Linhong Road  
Changning District, 200335  
Shanghai, P.R. China  
Tel: +86 21 5200-0099

**Europe/Africa/Middle East**  
Auf der Heide 2  
53947 Nettersheim, Germany  
Tel: +49 2486 809-0

**Asia-Pacific**  
100G Pasir Panjang Road  
#07-08 Interlocal Centre  
Singapore 118523  
Tel: +65 6825-1668

Friedensstraße 41  
68804 Altlußheim, Germany  
Tel: +49 6205 2094-0  
An den Nahewiesen 24  
55450 Langenlonsheim, Germany  
Tel: +49 6704 204-0

**For more information, please  
email us at [filtration@eaton.com](mailto:filtration@eaton.com)  
or visit [www.eaton.com/filtration](http://www.eaton.com/filtration)**

© 2021 Eaton. All rights reserved. All trademarks and registered trademarks are the property of their respective owners. All information and recommendations appearing in this brochure concerning the use of products described herein are based on tests believed to be reliable. However, it is the user's responsibility to determine the suitability for his own use of such products. Since the actual use by others is beyond our control, no guarantee, expressed or implied, is made by Eaton as to the effects of such use or the results to be obtained. Eaton assumes no liability arising out of the use by others of such products. Nor is the information herein to be construed as absolutely complete, since additional information may be necessary or desirable when particular or exceptional conditions or circumstances exist or because of applicable laws or government regulations.