

Type 8032 / SE32

Flowmeter / Flow transmitter / Flow threshold detector
Durchflussmessgerät / Durchflusstransmitter / Durchflussschwellendetektor
Débitmètre / Transmetteur de débit / Détecteur à seuil du débit



Operating Instructions

Bedienungsanleitung
Manuel d'utilisation

We reserve the right to make technical changes without notice.
Technische Änderungen vorbehalten.
Sous réserve de modifications techniques.

© Bürkert SAS, 2011-2017

Operating Instructions 1703/03_EU-ML 00560375 / Original_FR

1. ABOUT THESE OPERATING INSTRUCTIONS	6	6.1.3. Dimensions	11
1.1. Symbols used	6	6.1.4. Material data	11
1.2. Definition of the word "device"	6	6.1.5. Electrical data.....	12
2. INTENDED USE	7	6.2. Technical data of the 8032	13
3. BASIC SAFETY INFORMATION	7	6.2.1. Conditions of use	13
4. GENERAL INFORMATION	9	6.2.2. Compliance to standards and directives	13
4.1. Manufacturer's address and international contacts	9	6.2.3. Dimensions	14
4.2. Warranty conditions	9	6.2.4. Material data	14
4.3. Information on the Internet	9	6.2.5. Fluid data	14
5. DESCRIPTION	9	6.2.6. Electrical data of the 8032	15
5.1. Construction of the SE32	9	6.3. Technical data of the SE32 with S077 sensor-fitting ..	15
5.2. Construction of the 8032	9	6.3.1. Conditions of use	15
5.3. Construction of the SE32 with sensor-fitting S077	10	6.3.2. Compliance to standards and directives	15
5.4. Description of the name plate	10	6.3.3. Dimensions	16
6. TECHNICAL DATA	11	6.3.4. Material data	16
6.1. Technical data of the SE32	11	6.3.5. Fluid data	16
6.1.1. Conditions of use	11	6.3.6. Electrical data	17
6.1.2. Compliance to standards and directives	11	7. INSTALLATION AND WIRING	17
		7.1. Safety information	17

7.2. Fluid installation of the 8032	18	8. COMMISSIONING	32
7.2.1. Install the S030 sensor-fitting on the pipe	18	8.1. Safety information	32
7.2.2. Assemble the SE32 with the S030 sensor-fitting	20	9. ADJUSTMENT AND FUNCTIONS	33
7.2.3. Finalise the installation of the 8032	20	9.1. Safety information	33
7.3. Fluid installation of the SE32 with an S077 sensor-fitting	20	9.2. Operating levels	34
7.3.1. Install the S077 sensor-fitting on the pipe	20	9.3. Description of the display and the operating keys	35
7.3.2. Assemble the SE32 with the S077 sensor-fitting	21	9.4. Process level	35
7.3.3. Finalise the installation of the SE32 with S077 sensor-fitting	21	9.5. Configuration level - Parameters menu	37
7.4. Wiring	21	9.5.1. Selecting the unit of the flow rate	38
7.4.1. Data of the cables and wires	22	9.5.2. Entering the K-factor or having it determined by Teach-In	39
7.4.2. Assembling the connectors	22	9.5.3. Configuring the relay or transistor output	40
7.4.3. Wiring a version with transistor output and EN 175301-803 male fixed connector	23	9.5.4. Setting the flow rate range associated to the 4...20 mA output	42
7.4.4. Wiring a version with 2 transistor outputs and a 5-pin M12 male fixed connector	24	9.5.5. Choosing the filter of the flow rate.....	42
7.4.5. Wiring of the version with a single relay output	26	9.5.6. Entering the flow rate range related to the bar graph	43
7.4.6. Wiring of the version with a single current output	28	9.5.7. Adjusting the brightness of the backlight or deactivating the backlight	44
7.4.7. Wiring the version with both relay and current outputs (5-pin M12 male fixed connector).....	29	9.5.8. Activating and defining the access code to the Configuration level	44
7.4.8. Wiring the version with both relay and current outputs (8-pin M12 fixed connector).....	30	9.5.9. Saving the modified parameters	45

9.6. Configuration level - Test menu.....	46
9.6.1. Adjusting the 4...20 mA output	47
9.7. Default settings	48
9.8. Your settings for the 8032 / the SE32 with S077	48
10. MAINTENANCE AND TROUBLESHOOTING	49
10.1. Safety information	49
10.2. Maintenance and cleaning	49
10.3. If you encounter problems.....	50
11. SPARE PARTS AND ACCESSORIES	51
12. PACKAGING, TRANSPORT.....	52
13. STORAGE	52
14. DISPOSAL OF THE DEVICE	52

1. ABOUT THESE OPERATING INSTRUCTIONS

These Operating Instructions describe the entire life cycle of the device. Please keep these Operating Instructions in a safe place, accessible to all users and any new owners.

These Operating Instructions contain important safety information.

Failure to comply with these instructions can lead to hazardous situations. Pay attention in particular to the chapters [3. Basic safety information](#) and [2. Intended use](#).

- ▶ Whatever the version of the device, these Operating Instructions must be read and understood.

1.1. Symbols used



DANGER

Warns against an imminent danger.

- ▶ Failure to observe this warning will result in death or in serious injury.



WARNING

Warns against a potentially dangerous situation.

- ▶ Failure to observe this warning can result in serious injury or even death.



CAUTION

Warns against a possible risk.

- ▶ Failure to observe this warning can result in substantial or minor injuries.

NOTE

Warns against material damage.



indicates additional information, advice or important recommendations.



refers to information contained in these Operating Instructions or in other documents.

- ▶ Indicates an instruction to be carried out to avoid a danger, a warning or a possible risk.

→ Indicates a procedure to be carried out.

1.2. Definition of the word "device"

The word "device" used within these Operating Instructions refers to:

- the flowmeter / the flow threshold detector type 8032
or
- the flow transmitter / the flow threshold detector type SE32.

2. INTENDED USE

Use of a device that does not comply with the instructions could present risks to people, nearby installations and the environment.

The flowmeter / flow threshold detector type 8032 or the flow transmitter / flow threshold detector type SE32 are intended to measure the flow rate of liquids.

- ▶ Use this device in compliance with the characteristics and commissioning and use conditions specified in the contractual documents and in the Operating Instructions.
- ▶ Never use this device for security applications.
- ▶ Protect the device from electromagnetic perturbations, ultra-violet radiations and, when installed outside, from the effects of climatic conditions.
- ▶ Requirements for safe and proper operation are proper transport, storage and installation as well as careful operation and maintenance.
- ▶ Only operate a device in perfect working order.

3. BASIC SAFETY INFORMATION

This safety information does not take into account any contingencies or occurrences that may arise during installation, use and maintenance of the product.

The operating company is responsible for the respect of the local safety regulations including for the staff safety.



Danger due to high pressure in the installation.

Danger due to electrical voltage.

Danger due to high temperatures of the fluid.

Danger due to the nature of the fluid.



Various dangerous situations

To avoid injury:

- ▶ Do not use the device in explosive atmospheres.
- ▶ Do not use the device in an environment incompatible with the materials it is made of.
- ▶ Do not use fluid that is incompatible with the materials the device is made of.
- ▶ Do not make any modifications to the device.
- ▶ Do not subject the device to mechanical loads.
- ▶ Prevent any unintentional power supply switch-on.

Various dangerous situations (continued)

To avoid injury:

- ▶ Use the device only if in perfect working order and in compliance with the instructions provided in the Operating Instructions.
- ▶ Only qualified and skilled staff can carry out the installation and maintenance work.
- ▶ Guarantee a defined or controlled restarting of the process, after a power supply interruption.
- ▶ Observe the general technical rules.

NOTE

The device may be damaged by the fluid in contact with.

- ▶ Systematically check the chemical compatibility of the component materials of the device and the fluids likely to come into contact with them (for example: alcohols, strong or concentrated acids, aldehydes, alkaline compounds, esters, aliphatic compounds, ketones, halogenated aromatics or hydrocarbons, oxidants and chlorinated agents).

NOTE

Elements / Components sensitive to electrostatic discharges

This device contains electronic components sensitive to electrostatic discharges. They may be damaged if they are touched by an electrostatically charged person or object. In the worst case scenario, these components are instantly destroyed or go out of order as soon as they are activated.

- ▶ To minimise or even avoid all damage due to an electrostatic discharge, take all the precautions described in standard EN 61340-5-1.
- ▶ Also ensure that you do not touch any of the live electrical components.

4. GENERAL INFORMATION

4.1. Manufacturer's address and international contacts

To contact the manufacturer of the device, use following address:

Bürkert SAS

Rue du Giessen

BP 21

F-67220 TRIEMBACH-AU-VAL

You may also contact your local Bürkert sales office.

The addresses of our international sales offices are available on the internet at: www.burkert.com

4.2. Warranty conditions

The condition governing the legal warranty is the conforming use of the device in observance of the operating conditions specified in these Operating Instructions.

4.3. Information on the Internet

You can find the Operating Instructions and technical data sheets regarding the type 8032 and the type SE32 at: www.burkert.com

5. DESCRIPTION

5.1. Construction of the SE32

	<p>The SE32 is a flow transmitter / flow threshold detector with display.</p> <p>In a flow transmitter version, the SE32 has:</p> <ul style="list-style-type: none">- 1 current output and 1 relay output or- 1 current output <p>In a threshold detector version, the SE32 has 1 or 2 on/off outputs, i.e.:</p> <ul style="list-style-type: none">- 1 or 2 transistor output(s) NPN/PNP or- 1 relay output
--	---

5.2. Construction of the 8032

	<p>A: Sensor-fitting type S030 including the paddle-wheel flow sensor.</p> <p>B: Operating Instructions for the S030 sensor-fitting are available under www.burkert.com</p> <p>B : Flow transmitter / flow threshold detector type SE32 (see chap. 5.1).</p>
--	---

5.3. Construction of the SE32 with sensor-fitting S077

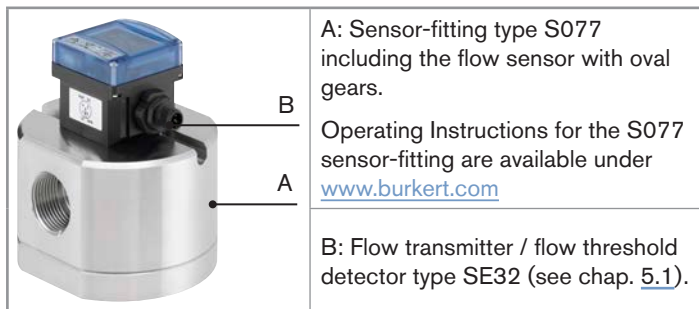

5.4. Description of the name plate

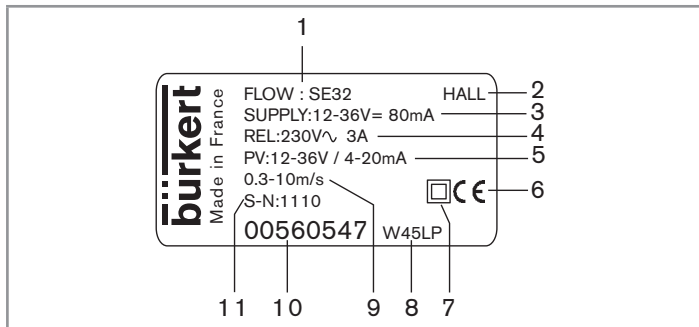

1. Measured process value and type of the device
2. Type of sensor
3. Power supply with maximum current consumption
4. Data of the on/off output
5. Data of the current output
6. Conformity marking
7. Symbol showing that the system is protected with a double insulation or a reinforced insulation
8. Manufacturing code
9. Measurement range of the flow rate
10. Order code
11. Serial number

Fig. 1 : Name plate (example)

6. TECHNICAL DATA

6.1. Technical data of the SE32

6.1.1. Conditions of use

Ambient temperature (in operation)	
▪ non-UL device	▪ -10...+60°C
▪ UL device	▪ 0...+40°C
Air humidity	< 80%, non condensated
Height above sea level	2000 m max.
Degree of pollution	Degee 2 acc. to EN 61010-1
Installation class	Class I acc. to UL 61010-1
Protection rating	IP65 acc. to EN 60529, device wired and connectors plugged-in and tightened or sealed



6.1.2. Compliance to standards and directives

The applied standards, which verify conformity with the EU Directives, can be found on the EU Type Examination Certificate and/or the EU Declaration of Conformity (if applicable).

UL-Certification

Finished products with variable key PU01 or PU02 are UL-certified products and comply also with the following standards:

- UL 61010-1
- CAN/CSA-C22.2 n°61010-1

Identification on the device	Certification	Variable key
	UL-recognized	PU01
 Measuring Equipment EXXXXXX	UL-listed	PU02

6.1.3. Dimensions

→ Please refer to the technical data sheet regarding the type SE32, available at: www.burkert.com

6.1.4. Material data

Part	Material
Housing / cover	PC, glass fiber reinforced
Front panel folio / Screws	Polyester / stainless steel
Cable plug / M12 connector	PA / PA or CuZn, nickel-plated
Name plate	Polyester

6.1.5. Electrical data

Power supply	12...36 V DC
Characteristics of the power source (not supplied)	<ul style="list-style-type: none"> ▪ Limited power source (in accordance with § 9.4 of the UL 61010-1 standard) ▪ or class 2 type power source (according to the 1310/1585 and 60950-1 standards)
Maximum current consumption	
▪ version with transistor output	▪ 50 mA
▪ version with 1 single relay output	▪ 70 mA
▪ version with 1 single current output	▪ 70 mA
▪ version with 1 relay and 1 current outputs	▪ 80 mA
▪ Drain current (UL device)	▪ 30...50 mA
Protection against polarity reversal	yes

Transistor output	<ul style="list-style-type: none"> ▪ NPN and/or PNP, 700 mA max., operation and thresholds can be parametered <ul style="list-style-type: none"> - NPN output: 0,2...36 V DC - PNP output: supply voltage ▪ protection against short circuits
Relay output (non-UL device)	<ul style="list-style-type: none"> ▪ single <ul style="list-style-type: none"> ▪ 3 A / 250 V AC or 3 A / 30 V DC, operation and thresholds can be parametered ▪ 3 A / 48 V AC or 3 A / 30 V DC, operation and thresholds can be parametered ▪ relay output + 4...20-mA-current output
Relay output (UL device)	<p>3 A / 30 V AC / 42 V_{peak} or 1 A / 60 V DC, operation and thresholds can be parametered</p> <p>To use the relay outputs in a wet location, observe the following safety instruction.</p>



DANGER

Danger due to the operation of the relay outputs of a UL device in a wet location.

- ▶ If a UL device is used in a wet location:
 - energize the relay outputs with an alternating voltage of max. 16 Vrms and 22,6 Vpeak.
 - or energize the relay outputs with a direct voltage of max. 35 V DC.

4...20-mA-current output
(for flow transmitter version)

- | | |
|---------------------------------|--|
| ▪ Accuracy | ▪ ±0,5% |
| ▪ Wiring | ▪ 4 wires |
| ▪ Loop resistance | ▪ 1300 Ω at 36 V DC,
1000 Ω at 30 V DC,
700 Ω at 24 V DC,
450 Ω at 18 V DC,
200 Ω at 12 V DC |
| ▪ Galvanically insulated | ▪ yes |
| ▪ 4 mA adjustment | ▪ between 3 and 5 mA |
| ▪ 20 mA adjustment | ▪ between 18,5 and 21,5 mA |
| ▪ Response time (10% up to 90%) | ▪ 3 s with filter 2 (default setting) |

6.2. Technical data of the 8032

6.2.1. Conditions of use

→ See conditions of use of the SE32, chap. [6.1.1, page 11](#).

6.2.2. Compliance to standards and directives

The applied standards, which verify conformity with the EU Directives, can be found on the EU Type Examination Certificate and/or the EU Declaration of Conformity (if applicable).



- Pressure: according to article 4§1 of the Pressure Equipment Directive 2014/68/EU, the device can only be used in the following cases (depending on the max. pressure, the DN of the pipe and the fluid):

Type of fluid	Conditions
Fluid group 1, art. 4 §1.c.i	DN ≤ 25
Fluid group 2, art. 4 §1.c.i	DN ≤ 32 or PNxDN ≤ 1000
Fluid group 1, art. 4 §1.c.ii	DN ≤ 25 or PNxDN ≤ 2000
Fluid group 2, art. 4 §1.c.ii	DN ≤ 200 or PN ≤ 10 or PNxDN ≤ 5000

UL-Certification

Finished products with variable key PU01 or PU02 are UL-certified products and comply also with the following standards:

- UL 61010-1
- CAN/CSA-C22.2 n°61010-1

Identification on the device	Certification	Variable key
	UL-recognized	PU01
 Measuring Equipment EXXXXXX	UL-listed	PU02

6.2.3. Dimensions

→ Please refer to the technical data sheets regarding the type 8032, available at: www.burkert.com

6.2.4. Material data

Part in contact with the medium	Material
▪ Sensor-fitting	▪ Refer to the Operating Instructions of the related sensor-fitting (S030)

→ Also see the material data of the type SE32, chap. [6.1.4.](#), page 11.

6.2.5. Fluid data

Pipe diameter	depends on the sensor-fitting used; The appropriate diameter of an S030 sensor-fitting is determined using the flow/DN/fluid velocity diagrams in chap. 7.2.1.
Type of fluid	Refer to the Operating Instructions of the related sensor-fitting (S030)
Rate of solid particles	max. 1%
Fluid temperature (see Fig. 2)	
▪ with S030 sensor-fitting in PVC	▪ 0...+50 °C
▪ with S030 sensor-fitting in PP	▪ 0...+80 °C
▪ with S030 sensor-fitting in stainless steel, brass or PVDF	▪ -15...+100 °C
Fluid pressure	
▪ with S030 sensor-fitting in metal	▪ PN16 max.
▪ with S030 sensor-fitting in plastic	▪ PN10 max.

Type 8032 - SE32

Technical data

Flow rate measurement	
▪ Measuring range	▪ 0,3...10 m/s,
▪ Measurement deviation	
- with standard K-factor of the S030 sensor-fitting	- $\pm 3\%$ of the measured value ¹⁾
- with K-factor determined with a Teach-In procedure	- $\pm 1\%$ of the measured value ¹⁾ (at the value of the Teach-In flow rate)
▪ Linearity ¹⁾	▪ $\pm 0,5\%$ of the full scale
▪ Repeatability ¹⁾	▪ $\pm 0,4\%$ of the measured value

¹⁾ These values were determined in the following reference conditions: medium = water, water and ambient temperatures 20°C, min. upstream and downstream distances respected, appropriate pipe dimensions

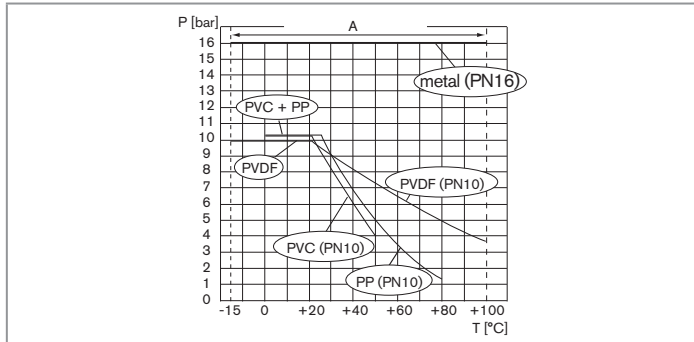

Fig. 2 : Fluid temperature / pressure dependency of the 8032, depending on the material the S030 sensor-fitting is made of

6.2.6. Electrical data of the 8032

→ See electrical data of the SE32, chap. 6.1.5, page 12.

6.3. Technical data of the SE32 with S077 sensor-fitting

6.3.1. Conditions of use

Ambient temperature (in operation)	
▪ non-UL device	▪ 0...+60°C
▪ UL device	▪ 0...+40°C
Air humidity	< 80%, non condensated
Height above sea level	2000 m max.
Degree of pollution	Degee 2 acc. to EN 61010-1
Installation class	Class I acc. to UL 61010-1
Protection rating	IP65 acc. to EN 60529, device wired and connectors plugged-in and tightened or sealed

6.3.2. Compliance to standards and directives

The applied standards, which verify conformity with the EU Directives, can be found on the EU Type Examination Certificate and/or the EU Declaration of Conformity (if applicable).



- Pressure: according to article 4§1 of the Pressure Equipment Directive 2014/68/EU, the device can only be used in the following cases (depending on the max. pressure, the DN of the pipe and the fluid):

Type of fluid	Conditions
Fluid group 1, art. 4 §1.c.i	forbidden
Fluid group 2, art. 4 §1.c.i	DN ≤ 32 or PNxDN ≤ 1000
Fluid group 1, art. 4 §1.c.ii	DN ≤ 25 or PNxDN ≤ 2000
Fluid group 2, art. 4 §1.c.ii	DN ≤ 200 or PN ≤ 10 or PNxDN ≤ 5000

UL-Certification

Finished products with variable key PU01 or PU02 are UL-certified products and comply also with the following standards:

- UL 61010-1
- CAN/CSA-C22.2 n°61010-1

Identification on the device	Certification	Variable key
	UL-recognized	PU01
 Measuring Equipment EXXXXXX	UL-listed	PU02

6.3.3. Dimensions

→ Please refer to the technical data sheets regarding the type SE32 associated with S077 sensor-fitting, available at: www.burkert.com

6.3.4. Material data

Part in contact with the medium	Material
▪ Sensor-fitting	▪ Refer to the Operating Instructions of the related sensor-fitting (S077)

→ Also see the material data of the type SE32, chap. [6.1.4](#), page 11.

6.3.5. Fluid data

Type of fluid	Refer to the Operating Instructions of the related sensor-fitting (S077)
Fluid temperature	
▪ with S077 sensor-fitting in aluminium	▪ -20...+80°C
▪ with S077 sensor-fitting in stainless steel	▪ -20...+120°C

Max. fluid pressure	
▪ DN15	▪ 55 bar (threaded process connection)
▪ DN25 / DN40 or DN50	▪ 55 bar ¹⁾ / 18 bar
¹⁾ (or in accordance to the value of the used flanges)	
▪ DN80 / DN100	▪ 12 bar / 10 bar
Flow rate measurement	
▪ Measuring range	
- viscosity > 5 mPa.s	- 2...1200 l/min
- viscosity < 5 mPa.s	- 3...616 l/min
▪ Measurement deviation	
- if "specific" K-factor is used (engraved on the sensor-fitting)	- ±0,5% of the measured value
- if "standard" K-factor is used	- ±1% of the measured value
▪ Repeatability	▪ ±0,03% of the measured value

6.3.6. Electrical data

→ See electrical data of the SE32, chap. [6.1.5, page 12](#).

7. INSTALLATION AND WIRING

7.1. Safety information



DANGER

Risk of injury due to high pressure in the installation

- ▶ Stop the circulation of fluid, cut off the pressure and drain the pipe before loosening the process connections.

Risk of injury due to high fluid temperatures.

- ▶ Use safety gloves to handle the device.
- ▶ Stop the circulation of fluid and drain the pipe before loosening the process connections.

Risk of injury due to the nature of the fluid.

- ▶ Respect the prevailing regulations on accident prevention and safety relating to the use of aggressive fluids.

Risk of injury due to electrical voltage.

- ▶ If a 12...36 V DC powered version is installed either in a wet environment or outdoors, all the electrical voltages must be of max. 35 V DC.
- ▶ Disconnect the electrical power for all the conductors and isolate it before carrying out work on the system.
- ▶ Do not unscrew the cover of a powered device.
- ▶ Observe all applicable accident protection and safety regulations for electrical equipment.



DANGER

Danger due to the operation of the relay outputs of a UL device in a wet location.

- ▶ If a UL device is used in a wet location:
 - energize the relay outputs with an alternating voltage of max. 16 Vrms and 22,6 Vpeak.
 - or energize the relay outputs with a direct voltage of max. 35 V DC.



WARNING

Risk of injury due to nonconforming installation.

- ▶ The electrical and fluid installation can only be carried out by qualified and skilled staff with the appropriate tools.
- ▶ Install appropriate safety devices (correctly rated fuse and/or circuit-breaker).
- ▶ Respect the assembly instructions for the sensor-fitting used.

Risk of injury due to unintentional switch on of power supply or uncontrolled restarting of the installation.

- ▶ Take appropriate measures to avoid unintentional activation of the installation.
- ▶ Guarantee a set or controlled restarting of the process subsequent to any intervention on the device.



Make sure that the device runs correctly, plug in and tighten the connectors.

7.2. Fluid installation of the 8032

The 8032 is inserted into an S030 sensor-fitting mounted on the pipe. The SE32 is assembled on the S030 sensor-fitting by a quarter-turn rotation system:

1. Install the S030 sensor-fitting on the pipe,
2. Assemble the SE32 with the S030 sensor-fitting,
3. Finalise the installation of the 8032.

7.2.1. Install the S030 sensor-fitting on the pipe

→ Select an S030 sensor-fitting suitable for the fluid in the pipes.

→ For thus, refer to the calculation tables [page 19](#).

These calculation tables are used to determine the DN of the sensor-fitting S030 appropriate to the application, according to the fluid velocity and the flow rate.



The names of the following norms have changed in the Operating Instructions:

- for the welding ends, norm BS 4825 is renamed BS 4825-1;
- for the clamp connections:
 - norme BS 4825 is renamed BS 4825-3
 - norm DIN 32676 is renamed DIN 32676 series A

Type 8032 - SE32

Installation and wiring

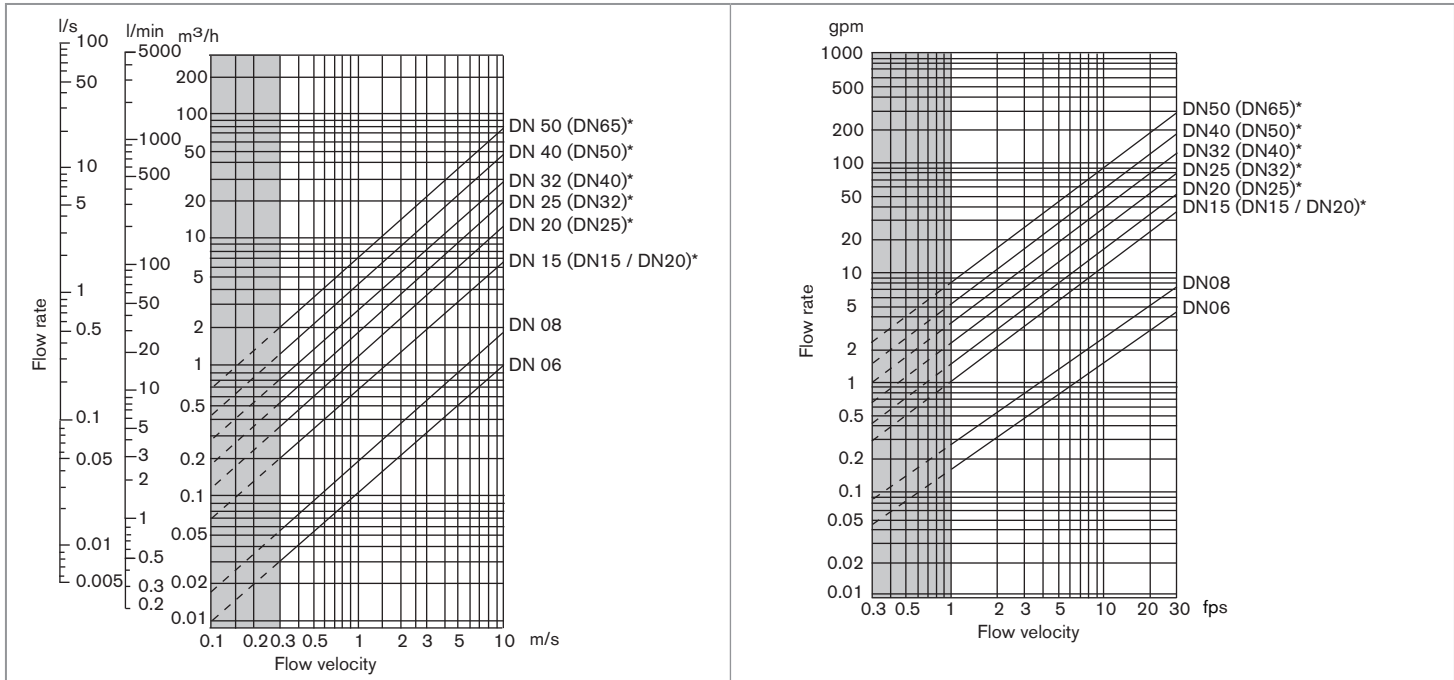

* for the following fittings:

- with external threads according to SMS 1145
- with weld ends according to SMS 3008, DIN 11866 series C / BS 4825-1 / ASME BPE, DIN 11850 series 2 / DIN 11866 series A / EN 10357 series A
- with clamp connections according to SMS 3017, BS 4825-3 / ASME BPE, DIN 32676 series A

7.2.2. Assemble the SE32 with the S030 sensor-fitting

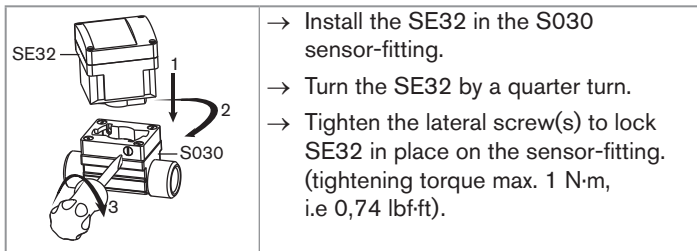

Fig. 3 : Installation of the SE32 in the S030 sensor-fitting

7.2.3. Finalise the installation of the 8032

- Wire the device and switch it on (see chap. 7.4).
- Set the K-factor or determine it with Teach-In (see chap 9.5.2)

7.3. Fluid installation of the SE32 with an S077 sensor-fitting

The SE32 is inserted into an S077 sensor-fitting mounted on the pipe. The SE32 is assembled on the S077 sensor-fitting by a quarter-turn rotation system:

1. Install the S077 sensor-fitting on the pipe,
2. Assemble the SE32 with the S077 sensor-fitting,
3. Finalise the installation.

7.3.1. Install the S077 sensor-fitting on the pipe

- Select an S077 sensor-fitting adapted to the viscosity of the fluid in the pipe.



To select a sensor-fitting, refer to the technical data sheet for the relevant sensor-fitting.



CAUTION

Risk of damage when installing the sensor-fitting.

- ▶ Follow the installation instructions given in the Operating Instructions for the sensor-fitting.
- Install the sensor-fitting S077 on the pipe in such a way that:
 - the spindles of the oval gears are set horizontally, as shown in Fig. 4.
 - the installation instructions given in the Operating Instructions of the sensor-fitting used are respected.

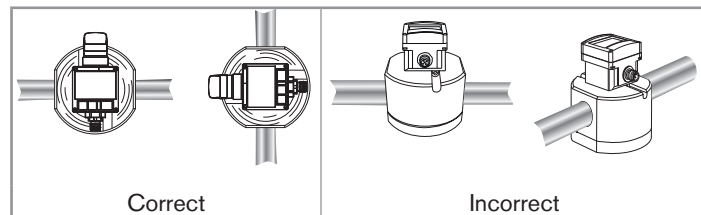

Fig. 4 : The spindles of the oval gears must be horizontal

7.3.2. Assemble the SE32 with the S077 sensor-fitting



The SE32 only detects one rotation direction of the oval gears of a S077 sensor-fitting.

- If the combination SE32 with sensor-fitting S077 does not run properly, once assembled and energized, do the following:
 - remove the SE32 from the S077 sensor-fitting,
 - turn the SE32 by 180°,
 - insert the SE32 back into the S077.

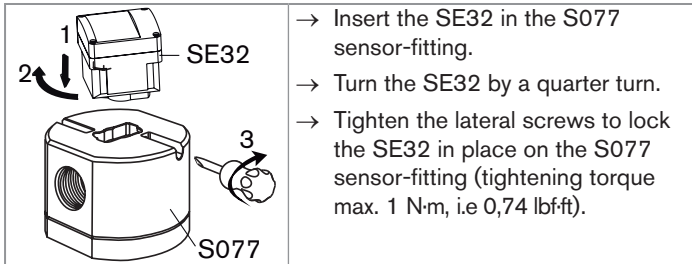

- Insert the SE32 in the S077 sensor-fitting.
- Turn the SE32 by a quarter turn.
- Tighten the lateral screws to lock the SE32 in place on the S077 sensor-fitting (tightening torque max. 1 N·m, i.e. 0,74 lbf·ft).

Fig. 5 : Installation of the SE32 in the S077 sensor-fitting

7.3.3. Finalise the installation of the SE32 with S077 sensor-fitting

- Wire the device and switch it on (see chap. 7.4).
- Set the K-factor or determine it with Teach-In (see chap 9.5.2)

7.4. Wiring



DANGER

Risk of injury due to electrical voltage

- ▶ If a 12...36 V DC powered version is installed either in a wet environment or outdoors, all the electrical voltages must be of max. 35 V DC.
- ▶ Disconnect the electrical power for all the conductors and isolate it before carrying out work on the system.
- ▶ Observe all applicable accident protection and safety regulations for electrical equipment.



- Use shielded cables with a temperature limit of 80°C minimum.
- Use a high quality electrical power supply, filtered and regulated.
- Protect the power supply by means of a 1 A fuse and a switch.
- Protect the power supply of each transistor by means of a 125 mA fuse.
- Protect the relays by means of a max. 3 A fuse and a circuit breaker (depending on the process).
- Do not apply both a dangerous voltage and a safety extra-low voltage to the relays.

7.4.1. Data of the cables and wires

Version	Type of connector
Detector with NPN transistor output	EN 175301-803 female connector (type 2508, supplied)
Detector with PNP transistor output	EN 175301-803 female connector (type 2508, supplied)
Detector with NPN/PNP transistor output	Female 5-pins M12 connector (not supplied)
Detector with relay output	EN 175301-803 female connector (type 2508, supplied) and female 5-pin M12 connector (not supplied)
Flowmeter with relay output	EN 175301-803 female connectors (type 2508 supplied) and female 8-pins M12 connector (not supplied) or female 5-pins M12 connector (not supplied)
Flowmeter without relay output	Female 5-pin M12 connector (not supplied)

Type of connector	Cable type
Female 5-pins M12 connector (order code 917 116)	<ul style="list-style-type: none"> ▪ shielded ▪ external diameter of wire: 3...6,5 mm ▪ cross section of wires: max. 0,75 mm²

Type of connector	Cable type
Female 8-pins M12 connector (order code 444 799)	<ul style="list-style-type: none"> ▪ shielded ▪ external diameter of wire: 5,9 mm ▪ cross section of wires: 0,25 mm²
Type 2508 (order code 438 811)	<ul style="list-style-type: none"> ▪ shielded ▪ external diameter of wire: 6...7 mm ▪ cross section of wires: 0,14...,5 mm²

7.4.2. Assembling the connectors

- Unscrew the nut [1] of the cable gland.
- Remove the terminal block [3] from the housing [2].
- Insert the cable through the nut [1] then through the gasket [4], through the cable gland and finally through the housing [2].
- Make the connections to the screw terminal block [3] (see chap. [7.4.3](#), [7.4.5](#), [7.4.7](#) or [7.4.8](#)).
- Position the terminal block [3] in steps of 90° then put it back into the housing [2], pulling gently on the cable so that the wires do not clutter the housing.
- Tighten the nut [1] of the cable gland.

Type 8032 - SE32

Installation and wiring

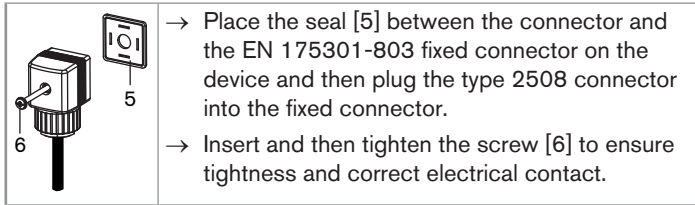

Fig. 6 : Assembling the female connector type 2508 (supplied)

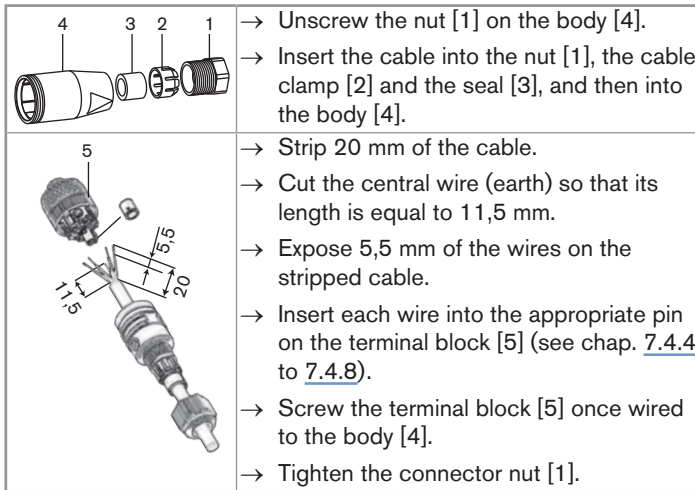

Fig. 7 : Assembling an female M12 connector (not supplied)

7.4.3. Wiring a version with transistor output and EN 175301-803 male fixed connector



DANGER

Risk of injury due to electrical voltage

- ▶ Always plug in and tighten the connectors correctly.



The device is not tight when the EN 175301-803 fixed connector is not wired:

- Unscrew the nut [1] (see Fig. 6) on the female connector type 2508 supplied with the device.
- Insert the plug with order code **444 509**, supplied with the device, into the cable gland.
- Screw the nut again.
- Plug the sealed type 2508 connector onto the EN 175301-803 fixed connector.

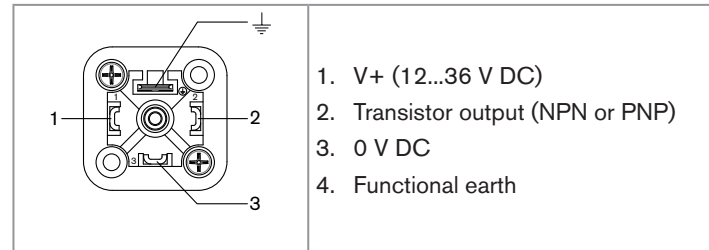

Fig. 8 : Pin assignment of the EN 175301-803 fixed connector

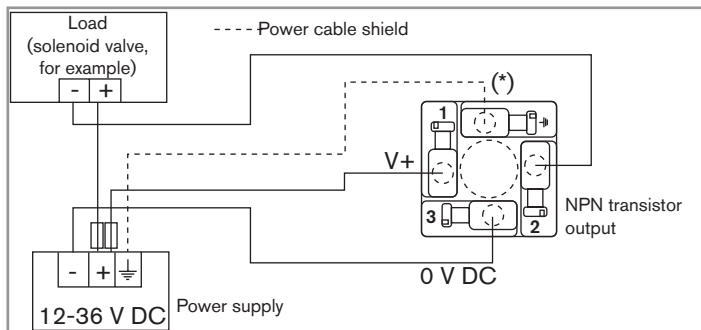

Fig. 9 : NPN wiring of the transistor output of a version with EN 175301-803 fixed connector

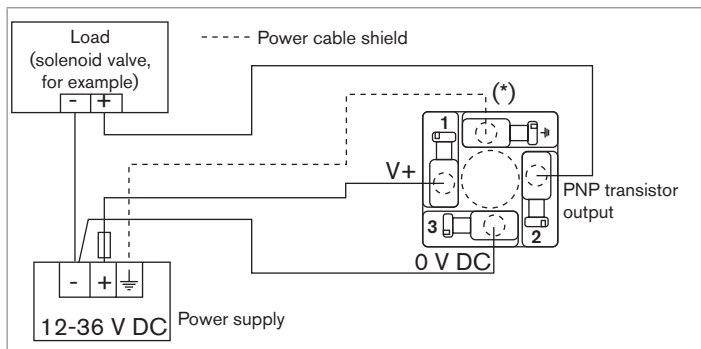

Fig. 10 : PNP wiring of the transistor output of a version with EN 175301-803 fixed connector

(*) Functional earth

7.4.4. Wiring a version with 2 transistor outputs and a 5-pin M12 male fixed connector



DANGER

Risk of injury due to electrical voltage

- ▶ Always plug in and tighten the connectors correctly.

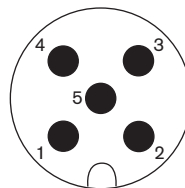

1. V+ (12...36 V DC)
2. NPN transistor output
3. 0 V DC
4. PNP transistor output
5. Functional earth

- The position of the 5-pin M12 fixed connector is adjustable:
- Unscrew the locknut.
- Turn the fixed connector to the desired position, by 360° max. to prevent the cables from twisting inside the housing.
- Tighten the locknut using a spanner, while keeping the fixed connector in the desired position.

Fig. 11 : Allocation of the pins on the 5-pin M12 male fixed connector

Type 8032 - SE32

Installation and wiring

Pin of the M12 female cable available as accessory equipment (order code 438 680)	Colour of the wire (signal)
1	brown (12...36 V DC)
2	white (NPN transistor output)
3	blue (0 V DC)
4	black (PNP transistor output)
5	grey (functional earth)

! When both transistor outputs are wired, they operate with the same settings made within the OUT function.

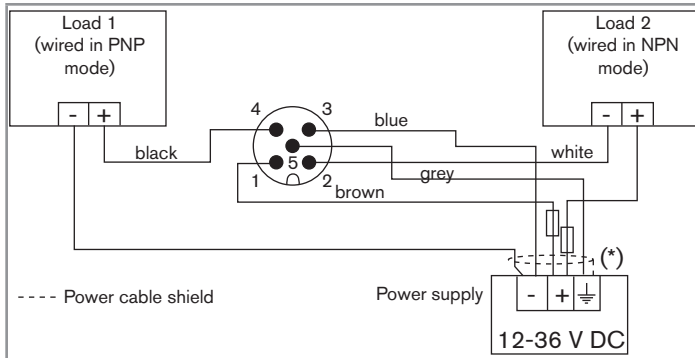

Fig. 12 : Wiring both transistor outputs on a version with a 5-pin M12 male fixed connector

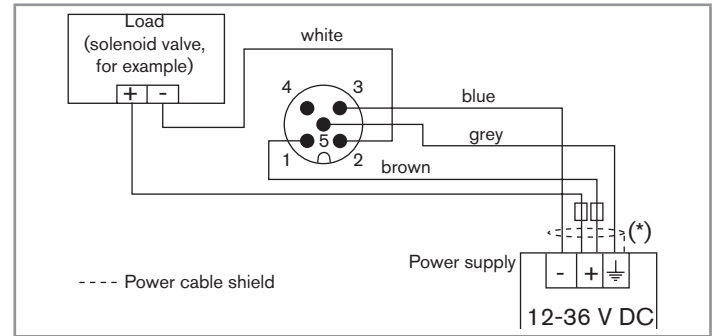

Fig. 13 : Wiring of the NPN transistor output of a version with a 5-pin M12 male fixed connector

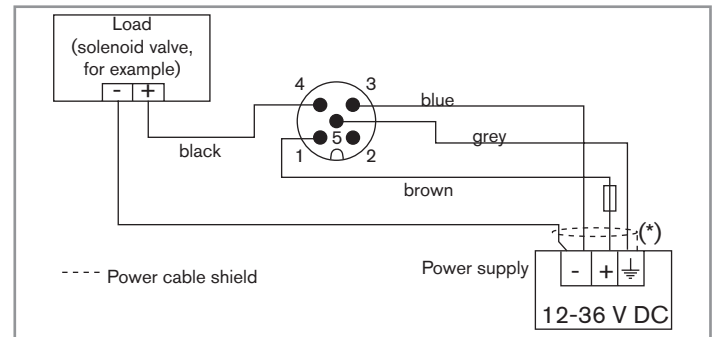

Fig. 14 : Wiring of the NPN transistor output of a version with a 5-pin M12 male fixed connector

(*) Functional earth

7.4.5. Wiring of the version with a single relay output

DANGER

Danger due to the operation of the relay outputs of a UL device in a wet location.

- ▶ If a UL device is used in a wet location:
 - energize the relay outputs with an alternating voltage of max. 16 Vrms and 22,6 Vpeak.
 - or energize the relay outputs with a direct voltage of max. 35 V DC.

WARNING

Shock hazard due to the voltage at the relay terminals, which is higher than 48 V.

- ▶ Before powering the device, always check that the connectors are correctly plugged-in and tightened.

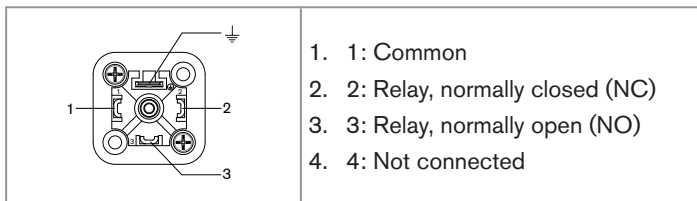

Fig. 15 : Pin assignment on the EN 175301-803 fixed connector



The device is not tight when the EN 175301-803 fixed connector is not wired:

- Unscrew the nut [1] (see Fig. 6) on the female connector type 2508 supplied with the device.
- Insert the plug with order code **444 509**, supplied with the device, into the cable gland.
- Screw the nut back.
- Plug the sealed type 2508 connector onto the EN 175301-803 fixed connector.

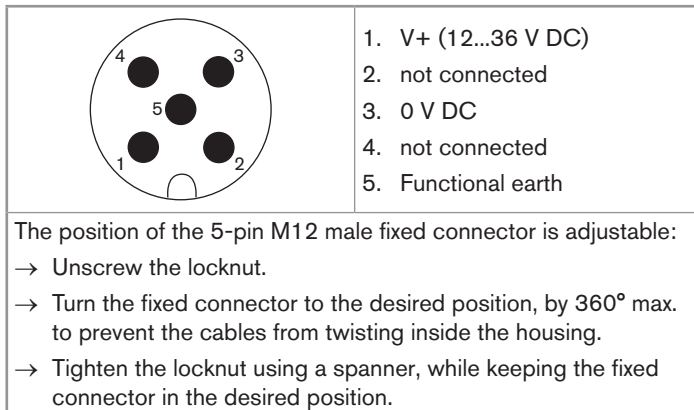

Fig. 16 : Pin assignment of the 5-pin M12 male fixed connector

Type 8032 - SE32

Installation and wiring

Pin of the M12 female cable available as accessory equipment (order code 438 680)	Colour of the wire (signal)
1	brown (V+)
2	not connected
3	blue (0 V DC)
4	not connected
5	grey (functional earth)

(1) Use a voltage limiter depending on the load selected, e.g. for the solenoid valve, an EN 175301-803 fixed connector with integrated varistor.

(*) Functional earth

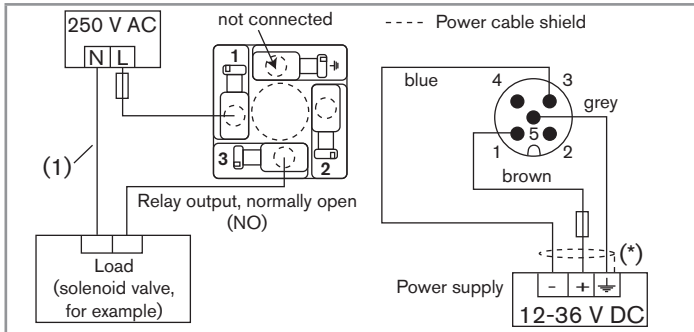

Fig. 17 : NO wiring of the relay output of a version with one 5-pin M12 and one EN 175301-803 fixed connectors

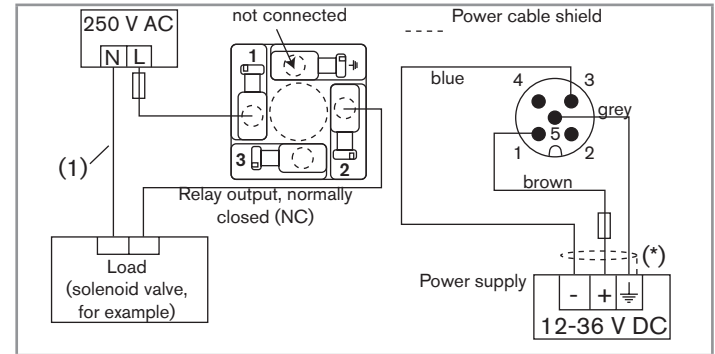
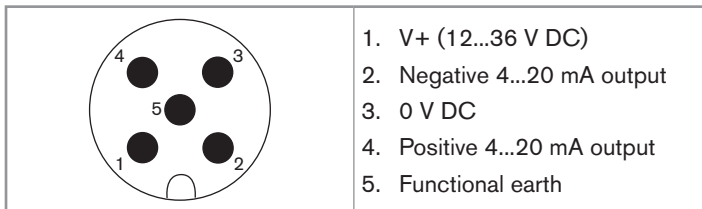

Fig. 18 : NC wiring of the relay output of a version with one 5-pin M12 and one EN 175301-803 fixed connectors

7.4.6. Wiring of the version with a single current output



The position of the 5-pin M12 male fixed connector is adjustable:

- Unscrew the locknut.
- Turn the fixed connector to the desired position, by 360° max. to prevent the cables from twisting inside the housing.
- Tighten the locknut using a spanner, while keeping the fixed connector in the desired position.

Fig. 19 : Pin assignment of the 5-pin M12 male fixed connector

Pin of the M12 female cable available as accessory equipment (order code 438 680)	Colour of the wire (signal)
1	brown (V+)
2	white (negative 4...20 mA output)
3	blue (0 V DC)
4	black (positive 4...20 mA output)
5	grey (functional earth)

The current output can be connected in either sourcing or sinking mode.

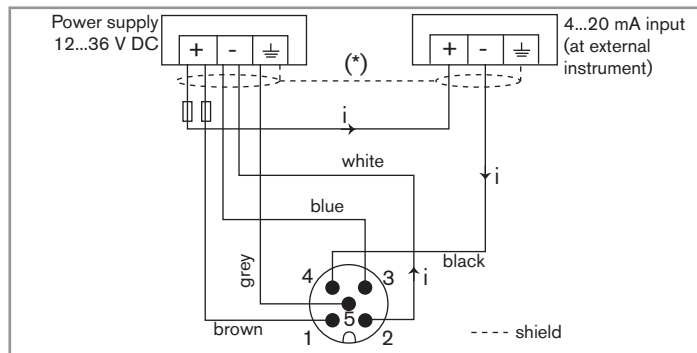

Fig. 20 : Wiring of the current output, in sinking mode, of a version with a single 5-pin M12 fixed connector

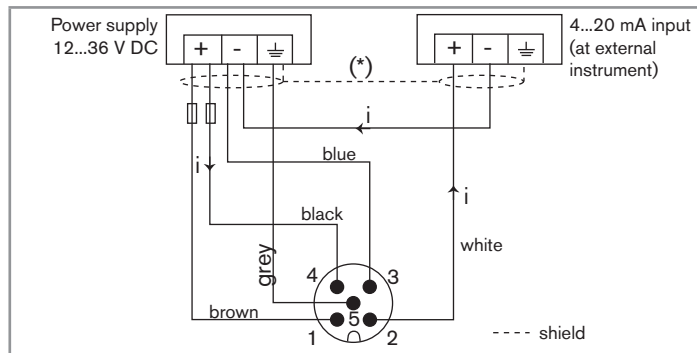

Fig. 21 : Wiring of the current output, in sourcing mode, of a version with a single 5-pin M12 male fixed connector

(*) Functional earth

7.4.7. Wiring the version with both relay and current outputs (5-pin M12 male fixed connector)

DANGER

Danger due to the operation of the relay outputs of a UL device in a wet location.

- ▶ If a UL device is used in a wet location:
 - energize the relay outputs with an alternating voltage of max. 16 Vrms and 22,6 Vpeak.
 - or energize the relay outputs with a direct voltage of max. 35 V DC.

WARNING

Shock hazard due to the voltage at the relay terminals, which is higher than 48 V.

- ▶ Before powering the device, always check that the connectors are correctly plugged-in and tightened.

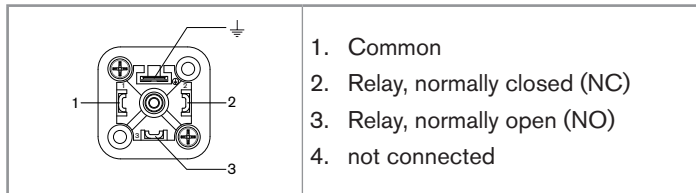
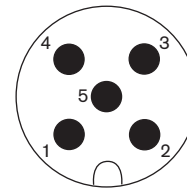

Fig. 22 : Pin assignment on the EN 175301-803 fixed connector



The device is not tight when the EN 175301-803 fixed connector is not wired:

- Unscrew the nut [1] (see Fig. 6) on the female connector type 2508 supplied with the device.
- Insert the plug with order code **444 509**, supplied with the device, into the cable gland.
- Screw the nut back.
- Plug the sealed type 2508 connector onto the EN 175301-803 fixed connector.



- | | |
|----|---------------------------|
| 1: | V+ (12...36 V DC) |
| 2: | Negative 4...20 mA output |
| 3: | 0 V DC |
| 4: | Positive 4...20 mA output |
| 5: | Functional earth |

The position of the 5-pin M12 male fixed connector is adjustable:

- Unscrew the locknut.
- Turn the fixed connector to the desired position, by 360° max. to prevent the cables from twisting inside the housing.
- Tighten the locknut using a spanner, while keeping the fixed connector in the desired position.

Fig. 23 : Pin assignment of the 5-pin M12 male fixed connector



The current output can be connected in either sourcing or sinking mode.

See [Fig. 26](#) and [Fig. 27](#) for the related wiring charts.

7.4.8. Wiring the version with both relay and current outputs (8-pin M12 fixed connector)



DANGER

Danger due to the operation of the relay outputs of a UL device in a wet location.

- ▶ If a UL device is used in a wet location:
 - energize the relay outputs with an alternating voltage of max. 16 Vrms and 22,6 Vpeak.
 - or energize the relay outputs with a direct voltage of max. 35 V DC.



WARNING

Shock hazard due to the voltage at the relay terminals, which is higher than 48 V.

- ▶ Before powering the device, always check that the connectors are correctly plugged-in and tightened.



The device is not tight when the EN 175301-803 fixed connector is not wired:

- Unscrew the nut [1] (see [Fig. 6](#)) on the female connector type 2508 supplied with the device.
- Insert the plug with order code **444 509**, supplied with the device, into the cable gland.
- Screw the nut back.
- Plug the sealed type 2508 connector onto the EN 175301-803 fixed connector.

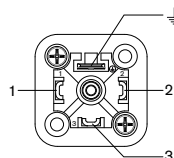

1. Common
2. Relay, normally closed (NC)
3. Relay, normally open (NO)
4. Not connected

Fig. 24 : Pin assignment on the EN 175301-803 fixed connector

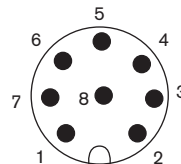

1. V+ (12...36 V DC)
2. Not connected
3. 0 V DC
4. Positive 4...20 mA output
5. Not connected
6. Negative 4...20 mA output
7. Not connected
8. Functional earth

Fig. 25 : Allocation of the pins on the M12, 8-pin fixed connector

Type 8032 - SE32

Installation and wiring

Pin of the 8-pin M12 female cable available as an accessory equipment (order code 444 800)	Colour of the wire (signal)
1	white (12...36 V DC)
2	not connected
3	green (0 V DC)
4	yellow (positive 4...20 mA output)
5	not connected
6	pink (negative 4...20 mA output)
7	not connected
8	grey (functional earth)

The current output can be connected in either sourcing or sinking mode.

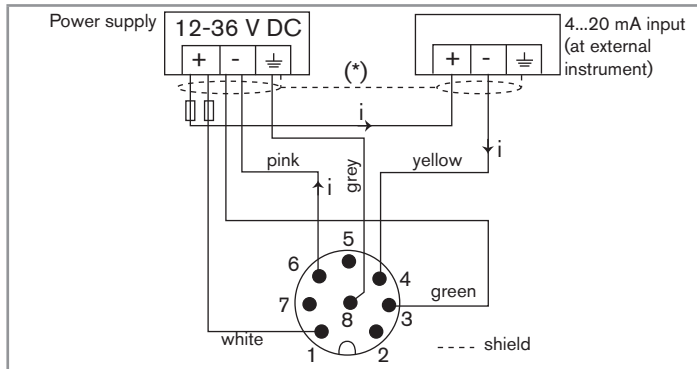

Fig. 26 : Wiring of the current output, in sinking mode, of a version with an 8-pin M12 fixed connector

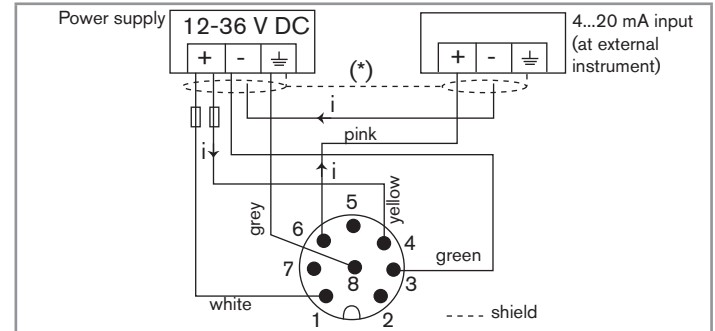

Fig. 27 : Wiring of the current output, in sourcing mode, of a version with an 8-pin M12 fixed connector

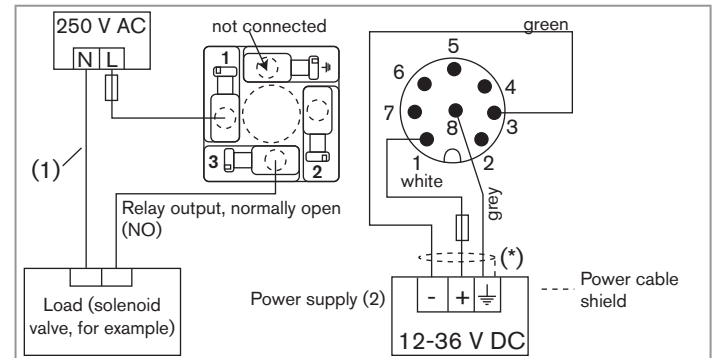

Fig. 28 : NO wiring of the relay output of a version with an 8-pin M12 fixed connector

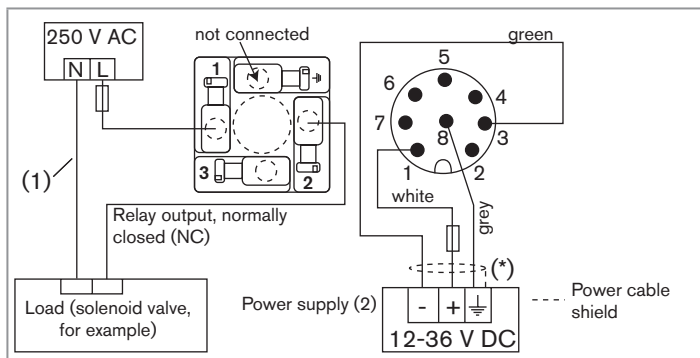

Fig. 29 : NC wiring of the relay output of a version with an 8-pin M12 fixed connector

(*) Functional earth

⁽¹⁾ Use a voltage limiter depending on the load selected, e.g. for the solenoid valve, an EN 175301-803 fixed connector with integrated varistor.

⁽²⁾ If the current output is needed, wire the 8-pin M12 connector acc. to Fig. 26 if the current output is wired in sinking mode, or acc. to Fig. 27 if the current output is wired in sourcing mode.

8. COMMISSIONING

8.1. Safety information



WARNING

Danger due to nonconforming commissioning.

Nonconforming commissioning could lead to injuries and damage the device and its surroundings.

- ▶ Before commissioning, make sure that the staff in charge have read and fully understood the contents of the manual.
- ▶ In particular, observe the safety recommendations and intended use.
- ▶ The device/installation must only be commissioned by suitably trained staff.
- ▶ Before commissioning the device, enter the K-factor of the fitting used. See chap. 9.4 and 9.5.

NOTE

Risk of damage to the device due to the environment

- ▶ Protect this device against electromagnetic interference, ultraviolet rays and, when installed outdoors, the effects of the climatic conditions.



- When the device is switched on and the cover is open, protection against electric shock is no longer guaranteed.
- Check the chemical compatibility between the fluid to be measured and the materials from which the device is made exposed to it.

9. ADJUSTMENT AND FUNCTIONS

9.1. Safety information



DANGER

Risk of injury due to electrical voltage

- ▶ If a 12...36 V DC powered version is installed either in a wet environment or outdoors, all the electrical voltages must be of max. 35 V DC.
- ▶ Observe all applicable accident protection and safety guidelines for electrical equipment.



WARNING

Risk of injury due to nonconforming adjustment.

- Nonconforming adjustment could lead to injuries and damage the device and its surroundings.
- ▶ The operators in charge of adjustment must have read and understood the contents of this manual.
 - ▶ In particular, observe the safety recommendations and intended use.
 - ▶ The device/installation must only be adjusted by suitably trained staff.

9.2. Operating levels



All settings may influence the correct running of the process.

- Note the values of the parameters set in the table at chap. 9.8.

The device has 2 operating levels:

- the Process level,
- the Configuration level.

The Configuration level comprises the Parameters and Test menus.

Operating level	Functions
Process	<ul style="list-style-type: none"> ▪ To read out: <ul style="list-style-type: none"> - the measured flow rate - the switching thresholds - the value of the 4...20 mA output (flowmeter only) ▪ To access the Parameters and Test menus of the Configuration level

Operating level	Functions
Configuration - Parameters menu	<ul style="list-style-type: none"> ▪ To make the settings needed for operation: <ul style="list-style-type: none"> - flow rate unit, - transistor or relay output, - filter, - bar graph, - K-factor, - 4...20-mA-current output (flowmeter only). ▪ To make the following additional settings: <ul style="list-style-type: none"> ▪ backlighting, ▪ access code to the Parameters and Test menus.
Configuration - Test menu	<ul style="list-style-type: none"> ▪ To test the configuration made in the Parameters menu with entering of a theoretical value. ▪ To read the frequency of the measured signal. ▪ To adjust the 4...20 mA output.

9.3. Description of the display and the operating keys

The display is used to:

- read the value of certain parameters such as the measured flow rate;
- parameterize the device by means of 3 keys;
- read the configuration of the device;
- get notification of some events.

		<ul style="list-style-type: none"> ▪ To change the value (0...9) of the selected digit; ▪ To go back to the previous function.
		<ul style="list-style-type: none"> ▪ To select the digit at the left; ▪ To go to the next function.
		<ul style="list-style-type: none"> ▪ To confirm the function displayed; ▪ To confirm the parameters set.

		Bar graph running in each mode, except during a Teach-In procedure.
		Shows the status of the on/off output (red LED).
		Shows if the relay is open or closed.
		Means that the access to the Parameters and Test menus is protected through a code.

Fig. 30 : Description of the keys and icons

9.4. Process level



The use and setting of the access code to the Parameters and Test menus are defined within the Parameters menu.

Display	displays...
Display A	...the measured flow rate
Display B (only flowmeters)	...the value of the 4...20 mA output.
Display C	...the value of the low switching threshold (<i>0 L0</i>).
Display D	...the value of the high switching threshold (<i>0 HI</i>).

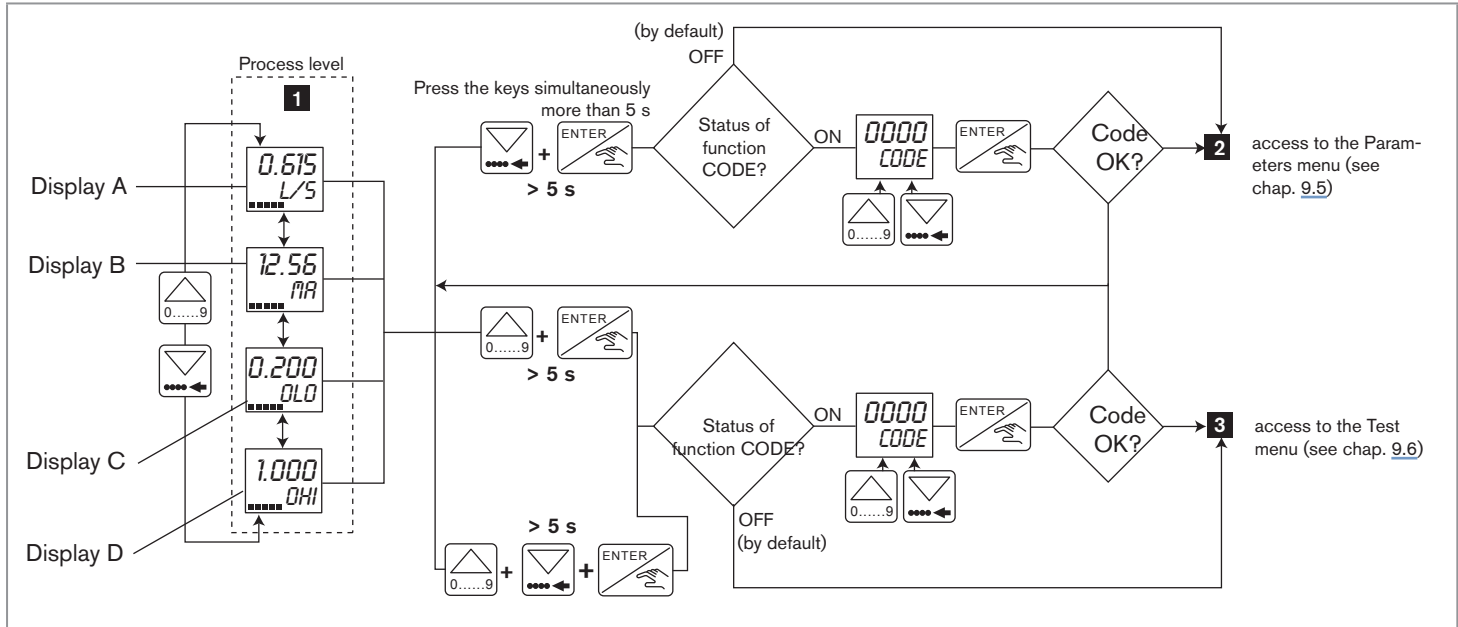

9.5. Configuration level - Parameters menu



All settings may influence the correct running of the process.

→ Note the values of the parameters set in the table at chap. [9.8](#).

Function	Description of the function
UNIT (see chap. 9.5.1)	To select the unit of the flow rate.
KFAC (see chap. 9.5.2)	To enter the K-factor of the sensor-fitting used or have it determined. The K-factor is specific to each sensor-fitting. It is used by the device to convert the measured signal into a flow rate.
OUT (see chap. 9.5.3)	<ul style="list-style-type: none"> ▪ To select: <ul style="list-style-type: none"> - the operation of the transistor or relay output (Hysteresis or Window); - whether the operation is inverted or not. ▪ To set: <ul style="list-style-type: none"> - the high (<i>0 HI</i>) and low (<i>0 LD</i>) switching thresholds; - the time delay before switching in seconds (<i>DEL</i>).
mA (see chap. 9.5.4)	To set the flow rate range associated to the 4...20 mA output.
FILT (see chap. 9.5.5)	<ul style="list-style-type: none"> ▪ To choose the filter of the displayed flow rate. Filter 0 means that flow rate variations are displayed. Filter 9 means that flow rate variations are attenuated to the maximum.
BRGR (see chap. 9.5.6)	To enter the flow rate range, minimum (<i>BG LD</i>) and maximum (<i>BG HI</i>) values, associated to the bar graph.
BKLG (see chap. 9.5.7)	To deactivate the backlighting of the display, or adjust its intensity and set the time-out after which it goes off.
CODE (see chap. 9.5.8)	To activate the use of the access code to the Parameters and Test menus. By default, the access code is not requested.
END (see chap. 9.5.9)	To go back to the Process level by saving or not the settings made.

9.5.1. Selecting the unit of the flow rate



WARNING

If the flow rate unit is modified, also modify the transistor or relay switching thresholds (function OUT), the threshold values of the bar graph (function BRGR) and the flow rate range associated to the current output (function mA).

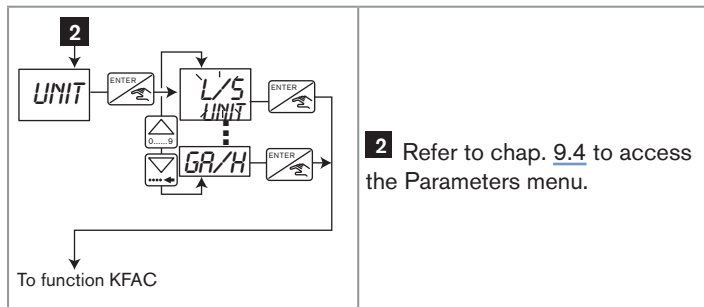

→ Select the desired unit of the flow rate.



9.5.2. Entering the K-factor or having it determined by Teach-In

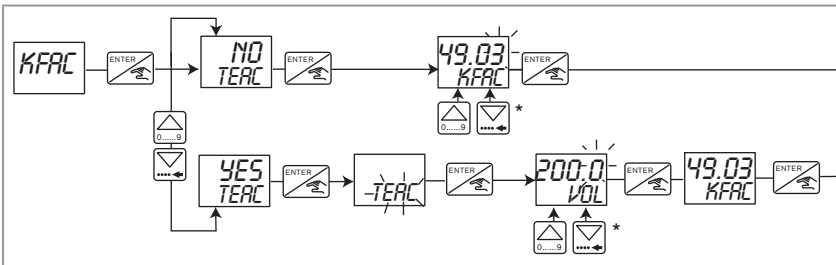

During the whole Teach-In procedure, the outputs are frozen to the status they had at the start of the Teach-In.



To function OUT

* to move the decimal point, simultaneously press keys  and 

- Entering the K-factor of the sensor-fitting used:
 - select "NO TEAC",
 - press key "ENTER",
 - In the KFAC parameter, enter the K-factor of the sensor-fitting used, in pulse/litre (value between 0,001 and 9999). Find the K-factor within the Operating Instructions of the sensor-fitting.
- Determining the K-factor by means of a Teach-In procedure:
 - install the device in series with a valve, for instance, then
 - fill a tank with x litres capacity (200 litres for example).
 - select "YES TEAC",
 - press key "ENTER",
 - open the valve: message "TEAC" blinks.
 - when the tank is full, press again key "ENTER".
 - enter the volume of liquid that has passed through the circuit (in the unit displayed alternately with the message "VOL"): the device calculates the K-factor and displays it.

9.5.3. Configuring the relay or transistor output

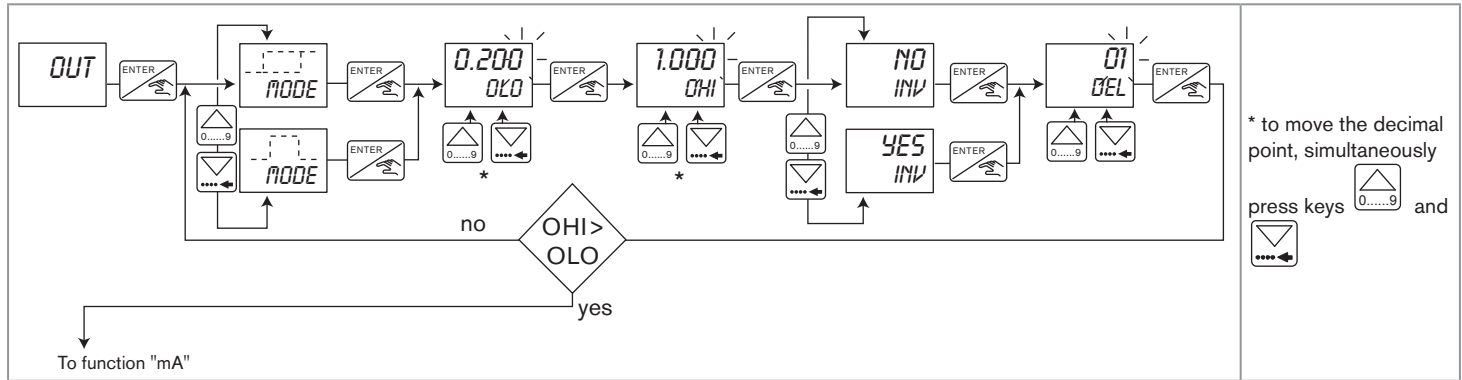

Type 8032 - SE32

Adjustment and functions

Hysteresis operation

The change of state is done when a threshold is detected (increasing flow rate: high threshold (OHI) to be detected, decreasing flow rate: low threshold (OLO) to be detected).

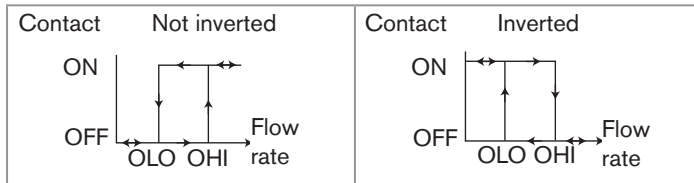

Fig. 31 : Hysteresis operation of the transistor output

Window operation

The change of state is done whenever one of the thresholds is detected.

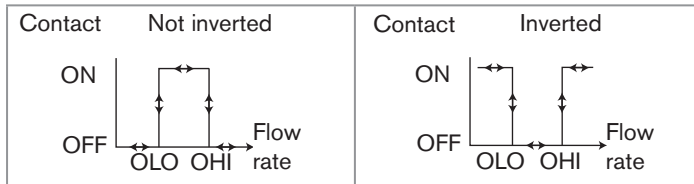

Fig. 32 : Window operation of the transistor output

The time delay (DEL) is valid for both output thresholds. switching is only done if one of the thresholds (OHI - OLO) is exceeded for a duration longer than this time delay.

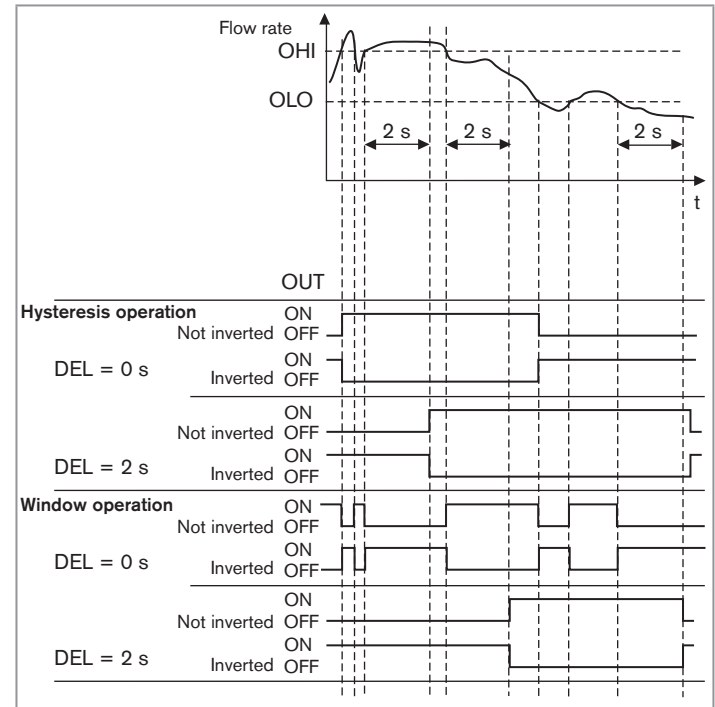

Fig. 33 : Examples for the behaviour of the transistor or relay output of a 8032 or a SE32 with S077, depending on the flow rate and the operation chosen.

9.5.4. Setting the flow rate range associated to the 4...20 mA output

The 4...20 mA output provides an electrical current, the value of which reflects the flow rate measured by the device.

- The signal may be inverted, i.e. the flow rate value associated to the 20-mA-current is lower than the one associated to the 4-mA-current.
- The current output gives a 22-mA-current when the device shows an operating error.

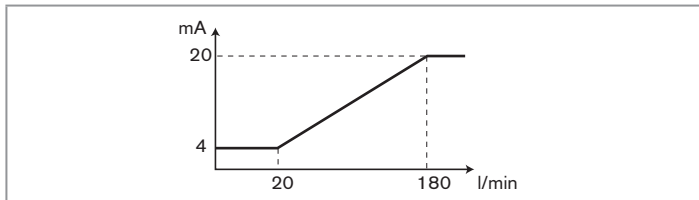
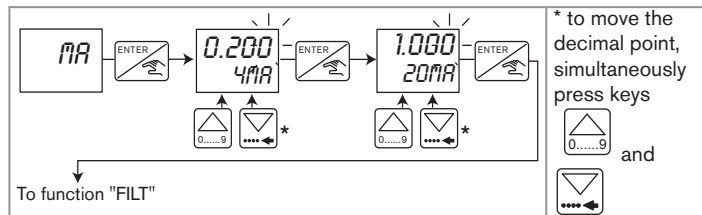
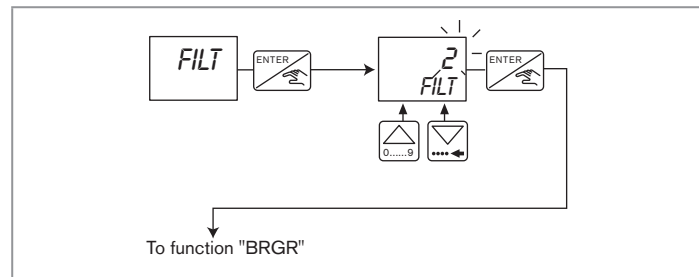

Fig. 34 : Example of relation between the measuring range and the current output



→ Enter the flow rate values, in the unit that has been chosen in the UNIT parameter, related to the 4...20-mA-current range.

9.5.5. Choosing the filter of the flow rate



The "Filter" function is used to attenuate the display and 4...20 mA output, if any, fluctuations when the flow rate varies in the process.

Ten attenuation levels, from 0 (means no attenuation) to 9 (maximum attenuation of the fluctuations) are available.

9.5.7. Adjusting the brightness of the backlight or deactivating the backlight

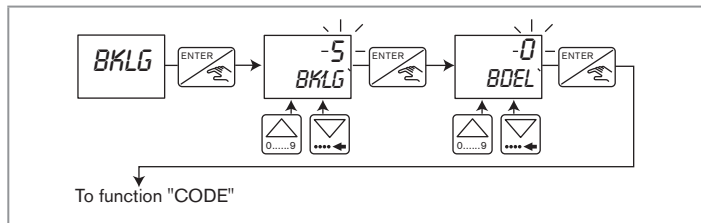

- Function "BKLG": to deactivate the backlight (choice "0") or to choose its intensity (choice "1" to "9").
- Function "BDEL": to have the backlight permanently activated (choice "00") or have it on for a constant duration (between "01" and "99" seconds) after a key press.
-

9.5.8. Activating and defining the access code to the Configuration level

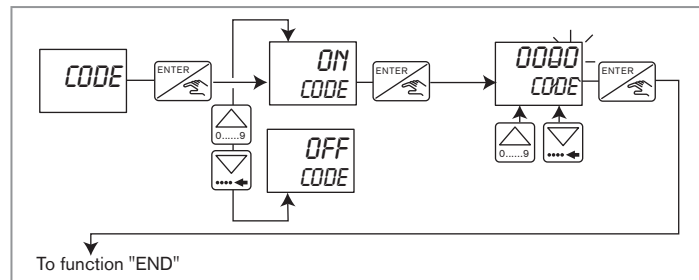

- Function "CODE ON": the access code to the Parameters and Test menu is required. Enter a 4-digit code.
- Function "CODE OFF": the access code to the Parameters and Test menu is not required.

9.5.9. Saving the modified parameters

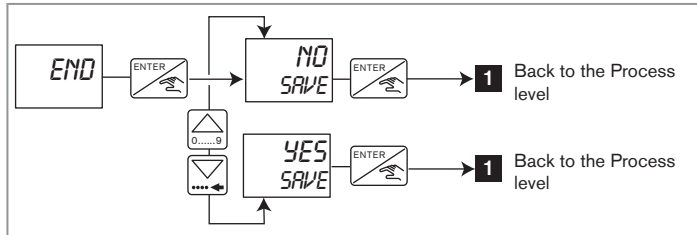

- Function "SAVE NO": the changes made within the Parameters menu are not saved. Is only displayed if any parameter has been changed.
- Function "SAVE YES": the changes made within the Parameters menu are saved. Is only displayed if any parameter has been changed.

9.6. Configuration level - Test menu

<p>3</p> <p>1 and 3: see chap. 9.4, Process level</p> <p>* to move the decimal point, simultaneously press keys and </p>	<p>FREQ</p> <p>To read the frequency of the measured signal.</p>
<p>SIM</p> <p>To test the switching thresholds set for the transistor output or the relay output and/or the conversion of the flow rate into mA, by entering a flow rate value.</p>	<p>SIM</p> <p>To test the switching thresholds set for the transistor output or the relay output and/or the conversion of the flow rate into mA, by entering a flow rate value.</p>
<p>mA</p> <p>see chap. 9.6.1</p> <p>MA</p> <p>To adjust the 4...20 mA output.</p>	<p>MA</p> <p>To adjust the 4...20 mA output.</p>
<p>END</p> <p>To go back to the Process level and display the flow rate measured.</p>	<p>END</p> <p>To go back to the Process level and display the flow rate measured.</p>

9.6.1. Adjusting the 4...20 mA output

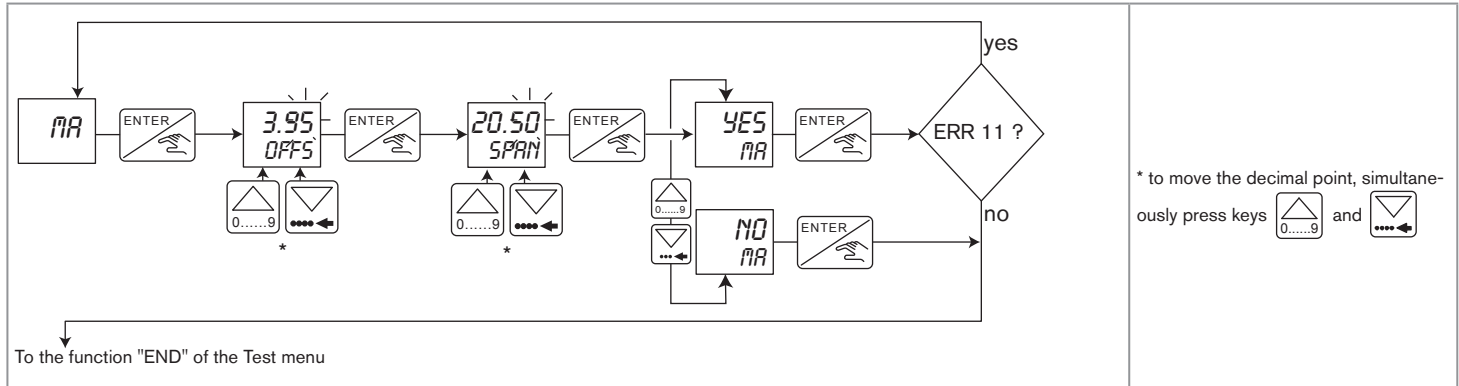

* to move the decimal point, simultaneously press keys and

- When the function "OFFS" is displayed, the device gives a 4-mA-current.
 - Measure the current given on the 4...20 mA output using a multimeter.
 - Enter this value in the function *OFFS*. The permitted offset range is 3 to 5 mA.
 - Press ENTER to confirm.

- When the function "SPAN" is displayed, the device gives a 20-mA-current.
 - Measure the current given on the 4...20 mA output using a multimeter.
 - Enter this value in the function *SPAN*. The permitted span range is 18,5...21,5 mA.
 - Confirm or do not confirm the values entered by choosing "YES MA" or "NO MA". When the message "ERR11" is displayed, at least one of the values entered is outside the permitted range: see chap. [10.3](#).

9.7. Default settings

At first power-up of the device, the configuration of the 8032 or the SE32 with S077 is the following:

Flow rate unit	K-factor	Relay or transistor output				Current output		Filter	Bar graph		Backlighting		Code
UNIT	KFAC	Operation	OLO threshold	OHI threshold	DEL	4 mA	20 mA	FILTER	BG LO	BG HI	BKLG	BDEL	CODE
l/s	1 imp./l	Hysteresis, inverted	0 ¹⁾	0 ¹⁾	0 s	0 ¹⁾	100 ¹⁾	2	0 ¹⁾	0 ¹⁾	5	0 s	0000 ²⁾

¹⁾ In the unit set within the UNIT function (l/s, by default).

²⁾ By default, the access code is not requested (CODE=OFF).

9.8. Your settings for the 8032 / the SE32 with S077

Flow rate unit	K-factor	Relay or transistor output				Current output		Filter	Bar graph		Backlighting		Code
UNIT	KFAC	Operation	OLO threshold	OHI threshold	DEL	4 mA	20 mA	FILTER	BG LO	BG HI	BKLG	BDEL	CODE

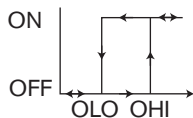

¹⁾ Hysteresis operation:

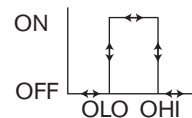

²⁾ Window operation:

10. MAINTENANCE AND TROUBLESHOOTING

10.1. Safety information



DANGER

Risk of injury due to high pressure in the installation

- ▶ Stop the circulation of fluid, cut off the pressure and drain the pipe before loosening the process connections.

Risk of injury due to electrical voltage

- ▶ Shut down the electrical power source of all the conductors and isolate it before carrying out work on the system.
- ▶ Observe all applicable accident protection and safety guidelines for electrical equipment.

Risk of injury due to high fluid temperatures

- ▶ Use safety gloves to handle the device.
- ▶ Stop the circulation of fluid and drain the pipe before loosening the process connections.
- ▶ Keep all easily flammable material and fluid away from the device.

Risk of injury due to the nature of the fluid

- ▶ Respect the regulations on accident prevention and safety relating to the use of aggressive fluids.



WARNING

Risk of injury due to non-conforming maintenance

- ▶ Maintenance must only be carried out by qualified and skilled staff with the appropriate tools.
- ▶ Guarantee a defined or controlled restarting of the process subsequent to any intervention on the device.

10.2. Maintenance and cleaning

NOTE

The device may be damaged by the cleaning product.

- ▶ Clean the device with a cloth slightly dampened with water or a cleaning liquid compatible with the materials the device is made of.

Please feel free to contact your Bürkert supplier for any additional information.

10.3. If you encounter problems

Message displayed	4...20 mA output, if present	Meaning	Recommended actio
ERR 2	22 mA	The Parameters menu cannot be accessed. Read fault of the menu: the process is not stopped.	→ Press the ENTER key to acknowledge the message. → If the failure occurs regularly, contact your retailer.
ERR 11	-	The span and/or offset values entered during adjustment of the 4...20 mA output are out of range: offset < 3 mA or > 5 mA and/or span < 18,5 mA or > 21,5 mA	→ Press the ENTER key to go back to the Test menu. The device operates with the previous adjustment values.

11. SPARE PARTS AND ACCESSORIES



CAUTION

Risk of injury and/or damage by the use of incorrect parts

Incorrect accessories and unsuitable spare parts may cause injuries and damage the device and the surrounding area.

- ▶ Use only original accessories and original spare parts from Bürkert.

Spare part	Order code
Complete unit ¹⁾ with NPN and PNP transistor outputs	563 103
Complete unit ¹⁾ with a single relay output	563 104
Complete unit ¹⁾ with a single current output	563 105
Complete unit ¹⁾ with both relay and 4...20 mA current outputs	563 106

¹⁾ Complete unit = cover, display and electronic board

Accessory	Order code
5-pin M12 female connector, to be wired	917 116
5-pin M12 female connector, moulded on shielded cable (2 m)	438 680
EN175301-803 female connector (type 2508) with cable gland	438 811
Plug for the cable gland of the type 2508 female connector	444 509
EN175301-803 female connector (type 2509) with NPT 1/2" reduction	162 673
8-pin M12 female connector, to be wired	444 799
8-pin M12 female connector, moulded on shielded cable (2 m)	444 800

12. PACKAGING, TRANSPORT

NOTE

Damage due to transport

Transport may damage an insufficiently protected device.

- ▶ Transport the device in shock-resistant packaging and away from humidity and dirt.
- ▶ Avoid the effects of heat and cold, which could cause the storage temperature range to be exceeded.
- ▶ Protect the electrical interfaces using protective plugs.

13. STORAGE

NOTE

Poor storage can damage the device.

- ▶ Store the device in a dry place away from dust.
- ▶ Ambient storage temperature: $-10...+60^{\circ}\text{C}$.

14. DISPOSAL OF THE DEVICE

→ Dispose of the device and its packaging in an environmentally-friendly way.

NOTE

Damage to the environment caused by parts contaminated by the fluid.

- ▶ Comply with the national and/or local regulations which concern the area of waste disposal.

www.burkert.com