

## NELES® TOP ENTRY, ROTARY CONTROL VALVE, SERIES TOP 5

Metso's Neles® T5 series top entry rotary ball valves are designed to meet the requirements of chemical, petro-chemical and refining industries with improved process safety and efficiency of plant. T5 series valves with famous trunnion mounted Stemball® design are suitable with wide rangeability for demanding heavy duty rotary control applications such as crude oil, hot residual oil, LPG and other hydrocarbon gases and vapors under medium and high pressures. Unique Stemball® design combined with anti-cavitation and low noise Q-trim technology are making the T5 series valve most suitable with wide rangeability for demanding control applications like anti surge and blow down services. The new high noise reduction Q2-trim is available for gas applications.

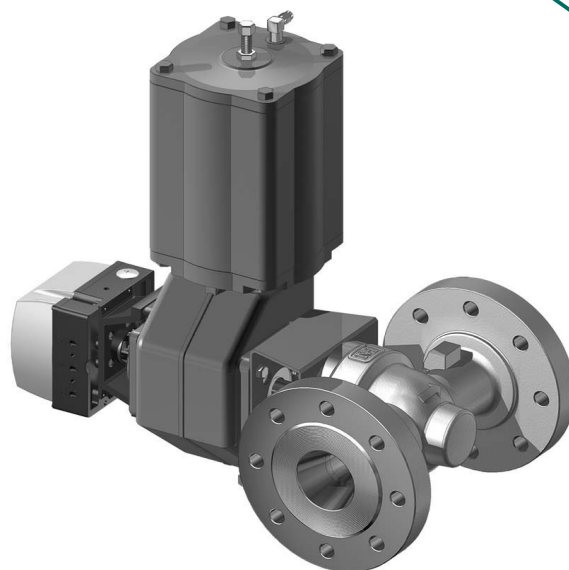

### FEATURES

#### Wide control rangeability

- Turndown ratio up to 150:1.

#### Alternative for globe control valves

- ASME globe valve face-to-face.
- Increased capacity.

#### Stable / accurate control

- Load caused by flow is carried by strong bearings.
- The single-piece Stemball® construction eliminates backlash, minimizing lost motion (deadband) in control applications.

#### Controls fluids with entrained solids

- Can handle fluids forming coke and crystallizing substances at high temperatures.
- Self cleaning trim design – scraping seat.

#### Tightness

- Long life metal to metal seats, for Class V tightness.
- Soft seated design for Class VI tightness.

#### Added security

- Fire-tested API 607.
- Stemball construction. – Anti-blow-out design.
- Rugged one-piece body resists pipe stresses.

#### Noise/cavitation abatement

- Patented Q-Trim design provides up to 18 dB(A) noise attenuation, self-flushing for impure fluids.
- Q-Trim + valve outlet attenuator plate construction extends Q-Trim performance for higher pressure drop ratios and provides extra noise attenuation.
- In severe applications – such as gas to flare or steam blow down – QX-Trim gives the best possible support to the seat by keeping spherical contact.
- High noise reduction Q2-trim for gas applications

#### Environmental design

- Rotary operation reduces emissions dramatically compared with most linear valves using standard packing.
- Packing constructions to meet ISO 15848 and US Clean Air Act requirements are available.
- Separate bonnet construction makes it possible to upgrade the valve to new requirements without modifying the valve body.
- Optional weld ends allow a 100% emission-free pipeline connection.

#### Options

- Oxygen construction for gaseous oxygen service.
- Low emission design construction to meet ISO 15848

### TECHNICAL SPECIFICATION

**Product type:** Top entry, trunnion mounted, single seated rotary control valve.

**Ratings:** See table below.

**Sizes:** See table below

**Type T5** Flanged, reduced bore 2" - 16", full bore 1" & 1 1/2", face-to-face acc. to ANSI/ISA-S75.03-1985 = IEC 534-3 part 3, (globe valve length).

**Type T4** Weld ends, reduced bore 2" - 16", full bore 1" & 1 1/2", face-to-face acc. to API 6D class 600.

**Temperature range:**  
 Seat A -50 ...+450 °C / -58...+840 °F  
 Seat E1-50 ...+450 °C / -58...+840 °F  
 Seat F -200 ...+400 °C / -320...+750 °F  
 Seat R -30 ...+100 °C / -22...+150 °F  
 Graphite packing must be used above 230 °C / +450 °F or in fire safe duty.

**Standard materials:** See table on page 5.

**Max. shut-off pressure:** See table on page 6 & 7.

**Max. control pressure:** See table on page 3.

**Flow characteristic:** Top 5 modified equal percentage. Q-Top 5 modified linear. See curves on page 3.

**Flow direction:** Flow from the seat side.

**Flow capacity:** See table on page 3.

**Rangeability:** 150:1.

**Valve ball rotation:** Clockwise to close.

**Fire safe:** API 607.

**Shut-off classification**  
**Standard tightness:** Metal seated; ASME/FCI 70.2 Class V. Soft seated; ASME/FCI 70.2 Class VI..

**Options**  
 Q-trim In sizes 8" and larger  
 QX-trim In sizes 01" - 06"  
 QXR-trim In sizes 01" - 06"  
 QA/QXA-trim (Q-trim + outlet attenuator) In all sizes  
 Q2G-trim In sizes 3" - 16"  
 V-port low CV trim In sizes 01" - 02".  
 For details see page 3.

### MAX. ALLOWABLE Δp IN CONTINUOUS THROTTLING CONTROL WITH COBALT BASED HARD FACING SEATS

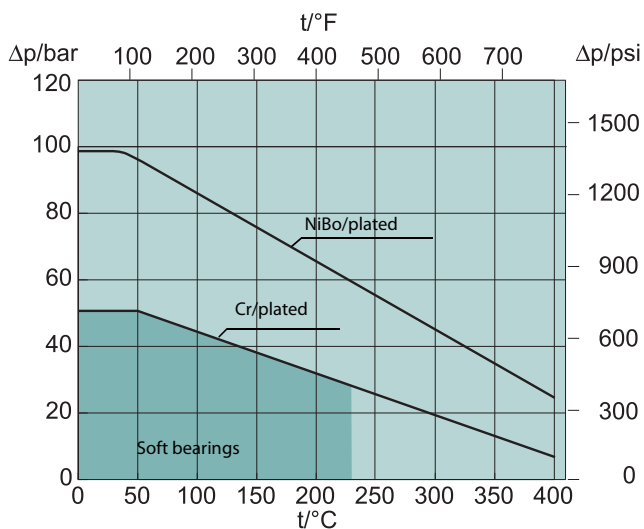

Note: Values given above are for pure fluids. For applications involving cavitation, impurities or excessive noise, contact Metso for max. Δp.

### INHERENT FLOW CHARACTERISTIC

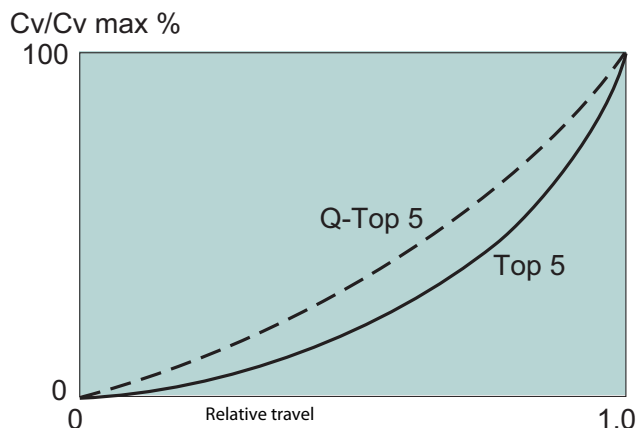

### NOISE ATTENUATION

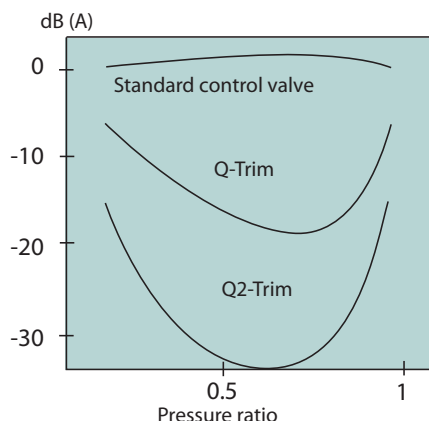

Maximum attainable noise attenuation.

**TRIM OPTIONS**

**Q-Trim®**

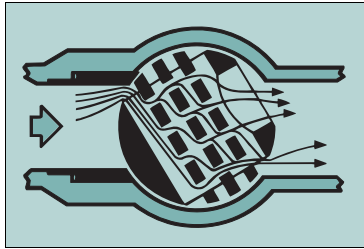

For noise and cavitation abatement.

**QX/QXR-Trim**

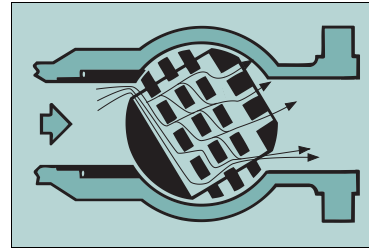

For noise and cavitation abatement. Drilled construction, no inserts.

QX = Full capacity

QXR = Reduced capacity

**V-port low  $C_v$  trim**

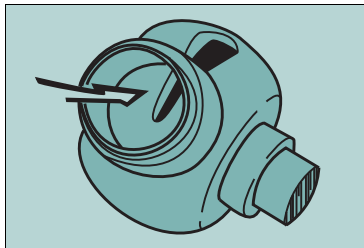

V-port for flow reduction.

For  $C_v$  values see table below (Maximum  $C_v$  values).

Reduction level is indicated after size.

**Q-Trim + attenuator plate**

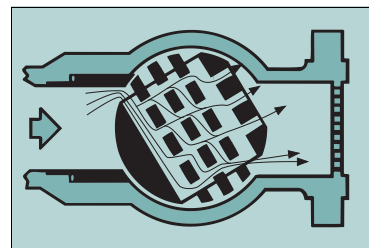

Attenuation plate construction extends Q- and QX-trim performance for higher pressure drop ratios and provides extra noise attenuation.

**MAXIMUM  $C_v$ -VALUES**

SIZE DN SIZE / red	SIZE INCH SIZE / red	T5/T4	Q/QX/QXR T5/T4
25	1	105	18
25/1	1/1	15	5
25/2	1/2	5	-
25/3	1/3	1.5	-
25/4	1/4	0.5	-
40	1.5	120	42
40/1	1.5/1	48.4	11
40/2	1.5/2	18.2	-
40/3	1.5/3	7.5	-
40/4	1.5/4	3.5	-
40/5	1.5/5	1.3	-
50	2	120	42
50/1	2/1	46.5	11
50/2	2/2	18	-
50/3	2/3	7.5	-
50/4	2/4	3.5	-
50/5	2/5	1.3	-
80	3	200	70
80/1	3/1	-	20
100	4	510	180
100/1	4/1	-	45
150	6	820	300
150/1	6/1	-	80
200	8	1150	470
250	10	1620	740
300	12	3000	1390
300	14	4600	2280
400	16	4600	2280

**Q2 Trim for gas applications**

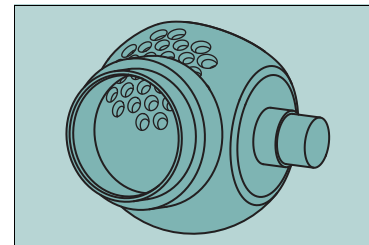

With new Q2-Trim technology, the noise reduction can be up to -30 dB(A). This creates the optimum solution for noise attenuation.

**STANDARD SEAT OPTIONS**

**A Metal seats**

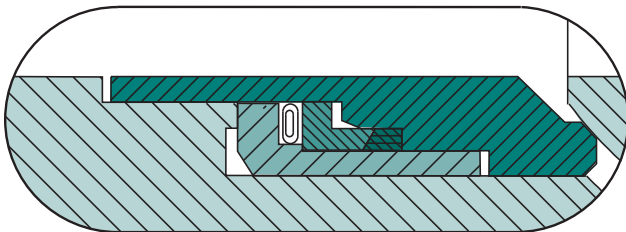

Ball seat: Stainless steel + cobalt based hard facing  
 Seat seal: Graphite  
 Back ring: 316 SS  
 Spring: Inconel® X-750  
 Temp. range: -50 .... +450 °C / -58....+840 °F  
 Size range: 01"....16" / DN 25....400  
 Service: General service and fire safe applications.

**E1 Metal seat for control service**

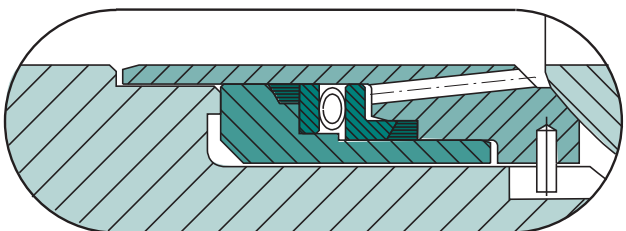

Ball seat: Stainless steel + cobalt based hard facing  
 Seat seal: Graphite  
 Back ring: 316 SS  
 Spring: Inconel® X-750  
 Temp. range: -50 .... +450 °C / -58....+840 °F  
 Size range: T5/T4 04"....16" / DN 100.... 400  
 Service: Control service, ejector style seat, lower torque in modulating control.

**F Bellows seat**

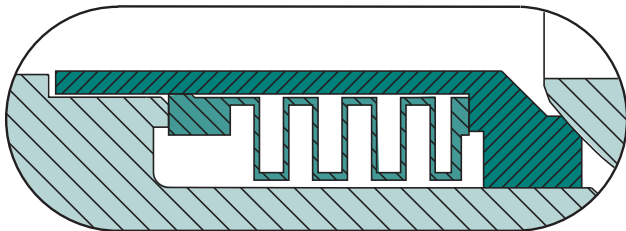

Ball seat: Stainless steel + cobalt based hard facing  
 Bellows: W.no 1.4418 = Avesta® 248 SV  
 Temp. range: -200 ... +400 °C / -330....+750 °F  
 Size range: T5/T4 01".... 8" / DN 25.... 200  
 Other sizes consult factory  
 Service: Control and shut-off applications at low and high temperatures.

**R63 Soft seat, fire safe design**

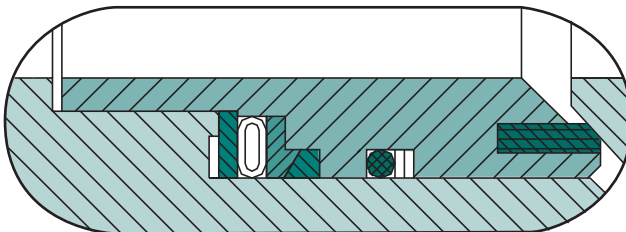

Ball seat: POM (Delrin®)  
 Seat seals: Viton® GF O-ring and Graphite  
 Back rings: 316 SS  
 Spring: Inconel® X-750  
 Temp. range: -30 ... +100 °C / -22....+150 °F  
 Size range: T5/T4 1 1/2".... 16" / DN 40.... 400  
 Service: Control and shut-off applications.

Delrin and Viton are registered trademarks of E.I. DuPont Co.  
 Avesta is a registered trademark of Avesta Stainless Co.  
 Inconel is a registered trademark of Inco.

**EXPLODED VIEW**

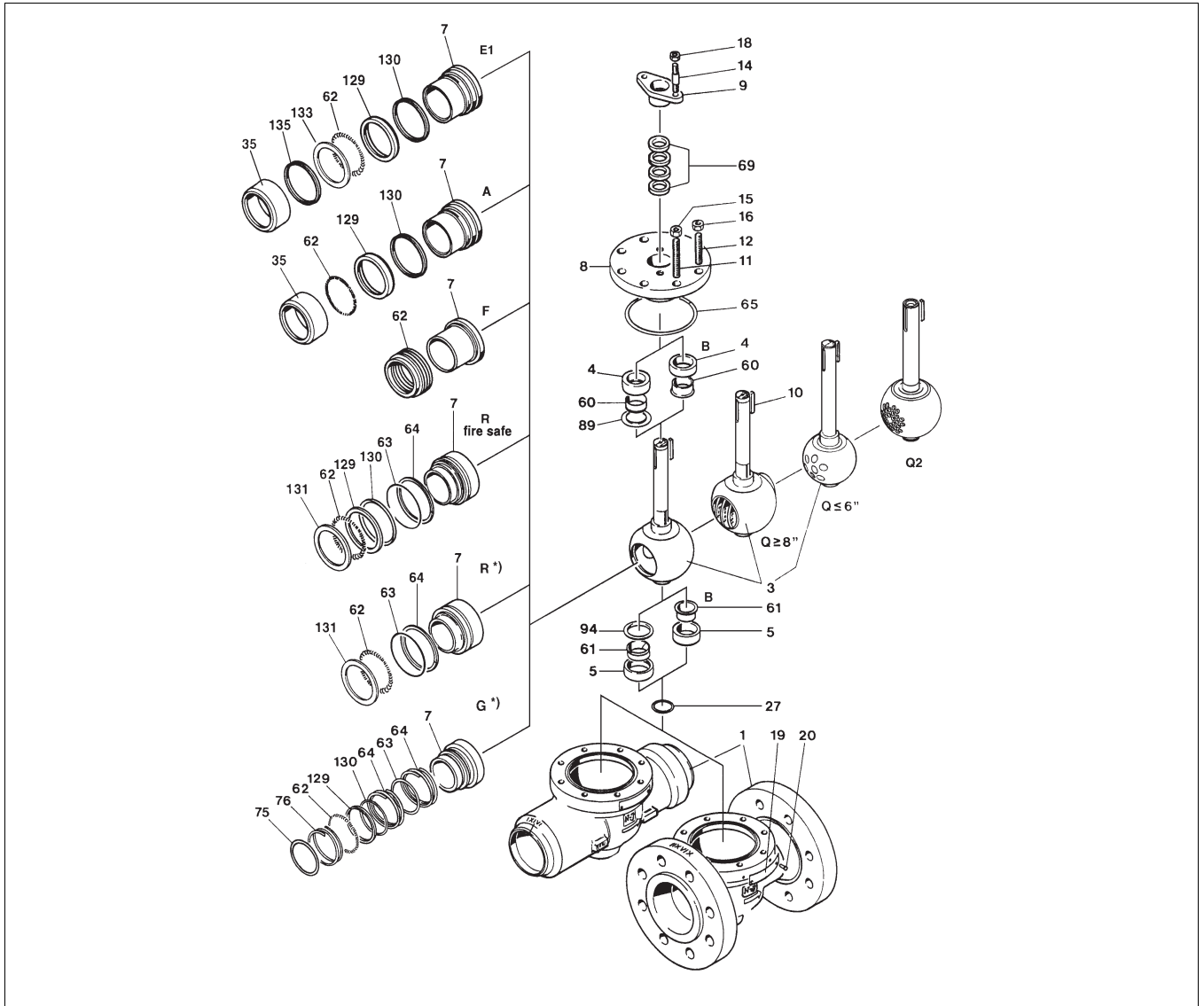

**BILL OF MATERIAL**

PART NO	DESCRIPTION	MATERIAL
1	Body	WCB / CF8M
3	Ball	CF8M with hard face
4	Thrust bearing	Stainless steel / Cobalt based alloy
5	Trunnion bearing	Stainless steel / Cobalt based alloy
7	Seat	Stainless steel + Cobalt based alloy / Stainless steel + Delrin®
8	Bonnet	WCB / CF8M
9	Gland	Stainless steel
10	Key	Stainless steel
11	Stud	Carbon steel / stainless steel
12	Stud	Carbon steel / stainless steel
14	Stud	Carbon steel / stainless steel
15	Hexagon nut	Carbon steel / stainless steel
16	Hexagon nut	Carbon steel / stainless steel
18	Hexagon nut	Carbon steel / stainless steel
19	Identification plate	Stainless steel

PART NO	DESCRIPTION	MATERIAL
20	Rivet	Carbon steel
27	Lock ring	Stainless steel Inconel X-750
35	Support ring	Stainless steel
60	Bearing bushing	PTFE on Stainless steel net / Nellalloy
61	Bearing bushing	PTFE on Stainless steel net / Nellalloy
62	Spring /bellows	Stainless steel Inconel X-750 / Avesta 248 SV
65	Gasket	Graphite
69	Gland packing	Graphite+PTFE / PTFE
89	Thrust bearing	PTFE on Stainless steel net
94	Thrust bearing	PTFE on Stainless steel net
129	Back seal	Graphite
130	Ring	Stainless steel

**DIMENSIONS**

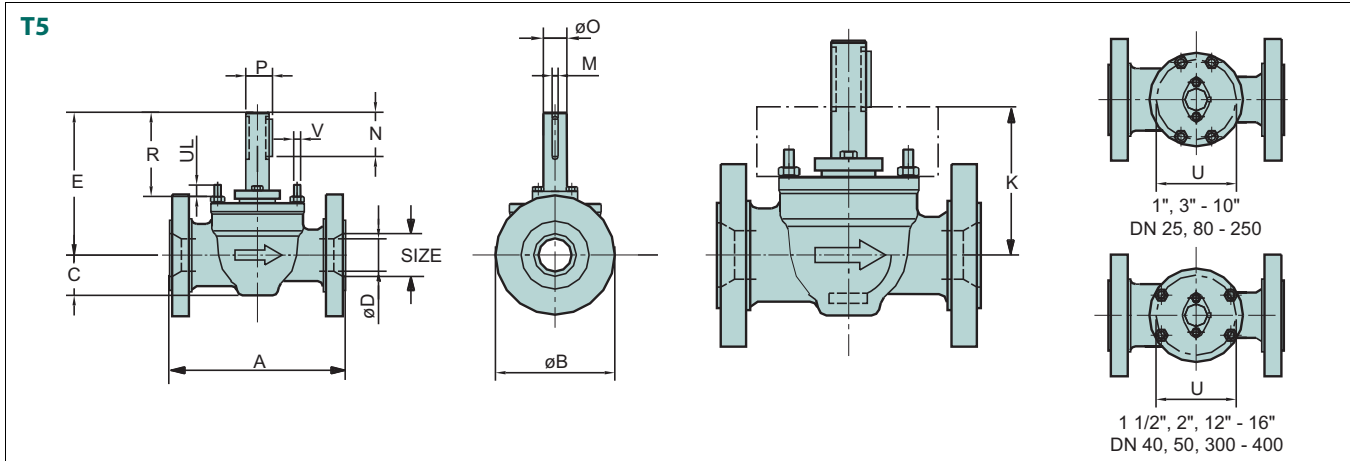

Type	DN	T5D/T5M		T5F/T5N/T5P			DIMENSIONS, mm														T5D/T5M	T5F/T5N/T5P
		A	B		A	B			C	$\phi D$	E	K	M	N	$\phi O$	P	R	U	UL	V	ASME 300 / PN 40	ASME 600 / PN 63, 100
			ASME 300	PN40		ASME 600	PN63	PN100													kg	kg
T5_01	25	197	124	115	210	124	140	140	38	25	158	133	4.76	25	15	16.96	89	84	22	3/8 UNC	10	11
T5_015	40	235	155	150	251	155	170	170	60	38	200	165	4.76	35	20	22.22	105	110	30	5/8 UNC	15	17
T5_02	50	267	165	165	286	165	180	195	60	38	200	165	4.76	35	20	22.22	105	110	30	5/8 UNC	19	21
T5_03	80	317	210	200	337	210	215	230	71	50	230	184	6.35	46	25	27.8	124	128	28	5/8 UNC	32	36
T5_04	100	368	254	235	394	273	250	265	90	76	280	222	9.52	58	35	39.1	138	173	43	3/4 UNC	56	69
T5_06	150	473	318	300	508	356	345	355	122	102	362	280	12.7	80	45	50.4	185	220	44	1 UNC	115	147
T5_08	200	568	381	375	610	419	415	430	140	125	415	325	12.7	90	55	60.6	208	272	44	1 UNC	239	287
T5_10	250	708	445	450	752	508	470	505	170	152	420	330	12.7	90	55	60.6	195	319	40	1 UNC	315	403
T5_12	300	775	521	515	819	559	530	585	210	202	520	401	19.05	119	70	78.2	235	400	56	1 1/4 UNC	530	613
T5_14	350	927	584	580	972	603	600	655	275	254	730	584	22.225	146	85	94.6	389	480	60	1 1/4 UNC	1050	1123
T5_16	400	1057	648	660	1108	686	670	-	275	254	730	584	22.225	146	85	94.6	389	480	60	1 1/4 UNC	1100	1228

Type	DN	T5D/T5M		T5F/T5N/T5P			DIMENSIONS, inch														T5D	T5F
		A	B		A	B			C	$\phi D$	E	K	M	N	$\phi O$	P	R	U	UL	V	ASME 300	ASME 600
			ASME 300	PN40		ASME 600	PN63	PN100													lbs	lbs
T5_01	1	7.76	4.88	4.53	8.27	4.88	5.51	5.51	1.50	0.98	6.22	5.24	0.19	0.98	0.59	0.67	3.50	3.31	0.87	3/8 UNC	22	24
T5_015	1.5	9.25	6.10	5.91	9.88	6.10	6.69	6.69	2.36	1.50	7.87	6.50	0.19	1.38	0.79	0.87	4.13	4.33	1.18	5/8 UNC	33	37
T5_02	2	10.51	6.50	6.50	11.26	6.50	7.09	7.68	2.36	1.50	7.87	6.50	0.19	1.38	0.79	0.87	4.13	4.33	1.18	5/8 UNC	42	46
T5_03	3	12.48	8.27	7.87	13.27	8.27	8.46	9.06	2.80	1.97	9.06	7.24	0.25	1.81	0.98	1.09	4.88	5.04	1.10	5/8 UNC	70	79
T5_04	4	14.49	10.00	9.25	15.51	10.75	9.84	10.43	3.54	2.99	11.02	8.74	0.37	2.28	1.38	1.54	5.43	6.81	1.69	3/4 UNC	123	152
T5_06	6	18.62	12.52	11.81	20.00	14.02	13.58	13.98	4.80	4.02	14.25	11.02	0.50	3.15	1.77	1.98	7.28	8.66	1.73	1 UNC	253	323
T5_08	8	22.36	15.00	14.76	24.02	16.50	16.34	16.93	5.51	4.92	16.34	12.80	0.50	3.54	2.17	2.39	8.19	10.71	1.73	1 UNC	526	631
T5_10	10	27.87	17.52	17.72	29.61	20.00	18.50	19.88	6.69	5.98	16.54	12.99	0.50	3.54	2.17	2.39	7.68	12.56	1.57	1 UNC	693	887
T5_12	12	30.51	20.51	20.28	32.24	22.01	20.87	23.03	8.27	7.95	20.47	15.79	0.75	4.69	2.76	3.08	9.25	15.75	2.20	1 1/4 UNC	1166	1349
T5_14	14	36.50	22.99	22.83	38.27	23.74	23.62	25.79	10.83	10.00	28.74	22.99	0.88	5.75	3.35	3.72	15.31	18.90	2.36	1 1/4 UNC	2310	2471
T5_16	16	41.61	25.51	25.98	43.62	27.01	26.38	-	10.83	10.00	28.74	22.99	0.88	5.75	3.35	3.72	15.31	18.90	2.36	1 1/4 UNC	2420	2702

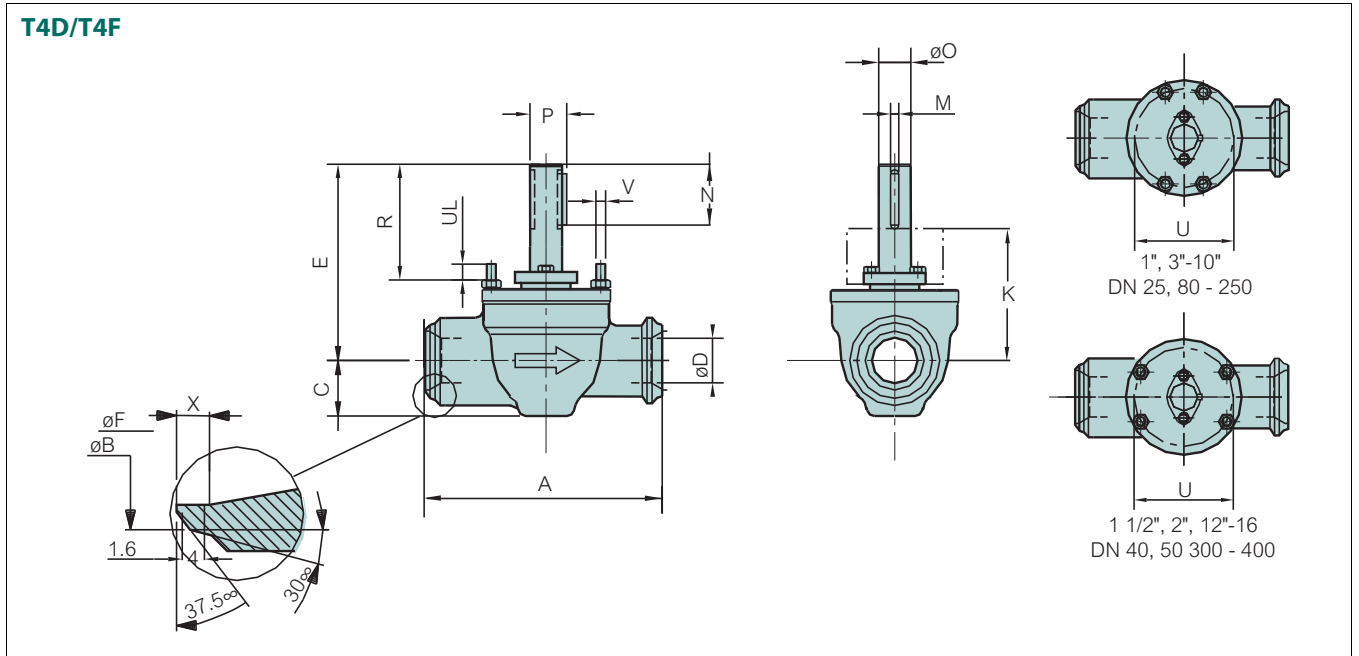

DIMENSIONS, mm																				
Type	DN	A	øB	C	øD	E	T4D	T4F	K	M	N	øO	P	R	U	V	UL	T4D	T4F	kg
							øF	øF										Xmin	Xmin	
T4_01	25	210	36	38	25	158	26.6	24.4	133	4.76	25	15	16.95	89	84	3/8 UNC	22	-	-	10
T4_015	40	251	52	60	38	200	40.6	37.8	165	4.76	35	20	22.22	105	110	5/8 UNC	30	-	-	15
T4_02	50	292	62	60	38	200	52.5	49.3	165	4.76	35	20	22.22	105	110	5/8 UNC	30	7	9.5	18
T4_03	80	356	91	71	50	230	77.9	73.7	184	6.35	46	25	27.8	124	128	5/8 UNC	28	10	13	32
T4_04	100	432	117	90	76	280	102.3	97.1	222	9.52	58	35	39.1	138	173	3/4 UNC	43	11	15	65
T4_06	150	559	172	122	102	362	154.1	146.3	280	12.7	80	45	50.4	185	220	1 UNC	44	13	20	125
T4_08	200	660	223	140	125	415	202.7	188.9	325	12.7	90	55	60.6	208	272	1 UNC	44	15.2	25.5	210
T4_10	250	787	278	170	152	420	254.4	242.8	330	12.7	90	55	60.6	195	319	1 UNC	40	17.7	26.5	275
T4_12	300	838	329	210	202	520	303.2	288.8	401	19.05	119	70	78.2	235	400	1 1/4-8 UN	56	19.3	30	475
T4_14	350	889	362	275	254	730	333.4	317.6	584	22.225	146	85	94.6	389	480	1 1/4-8 UN	60	30	30	930
T4_16	400	991	413	275	254	730	381	363.6	584	22.225	146	85	94.6	389	480	1 1/4-8 UN	60	35	30	960

DIMENSIONS, inch																				
Type	DN	A	øB	C	øD	E	T4D	T4F	K	M	N	øO	P	R	U	V	UL	T4D	T4F	lbs
							øF	øF										Xmin	Xmin	
T4_01	1	8.27	1.42	1.50	0.98	6.22	1.05	0.96	5.24	0.19	0.98	0.59	0.67	3.50	3.31	3/8 UNC	0.87	-	-	22
T4_015	1.5	9.88	2.05	2.36	1.50	7.87	1.60	1.49	6.50	0.19	1.38	0.79	0.87	4.13	4.33	5/8 UNC	1.18	-	-	33
T4_02	2	11.50	2.44	2.36	1.50	7.87	2.07	1.94	6.50	0.19	1.38	0.79	0.87	4.13	4.33	5/8 UNC	1.18	0.28	0.37	39.6
T4_03	3	14.02	3.58	2.80	1.97	9.06	3.07	2.90	7.24	0.25	1.81	0.98	1.09	4.88	5.04	5/8 UNC	1.10	0.39	0.51	70.4
T4_04	4	17.01	4.61	3.54	2.99	11.02	4.03	3.82	8.74	0.37	2.28	1.38	1.54	5.43	6.81	3/4 UNC	1.69	0.43	0.59	143
T4_06	6	22.01	6.77	4.80	4.02	14.25	6.07	5.76	11.02	0.50	3.15	1.77	1.98	7.28	8.66	1 UNC	1.73	0.51	0.79	275
T4_08	8	25.98	8.78	5.51	4.92	16.34	7.98	7.44	12.80	0.50	3.54	2.17	2.39	8.19	10.71	1 UNC	1.73	0.60	1.00	462
T4_10	10	30.98	10.94	6.69	5.98	16.54	10.02	9.56	12.99	0.50	3.54	2.17	2.39	7.68	12.56	1 UNC	1.57	0.70	1.04	605
T4_12	12	32.99	12.95	8.27	7.95	20.47	11.94	11.37	15.79	0.75	4.69	2.76	3.08	9.25	15.75	1 1/4-8 UN	2.20	0.76	1.18	1045
T4_14	14	35.00	14.25	10.83	10.00	28.74	13.13	12.50	22.99	0.88	5.75	3.35	3.72	15.31	18.90	1 1/4-8 UN	2.36	1.18	1.18	2046
T4_16	16	39.02	16.26	10.83	10.00	28.74	15.00	14.31	22.99	0.88	5.75	3.35	3.72	15.31	18.90	1 1/4-8 UN	2.36	1.38	1.18	2112

**VALVE + ACTUATOR**

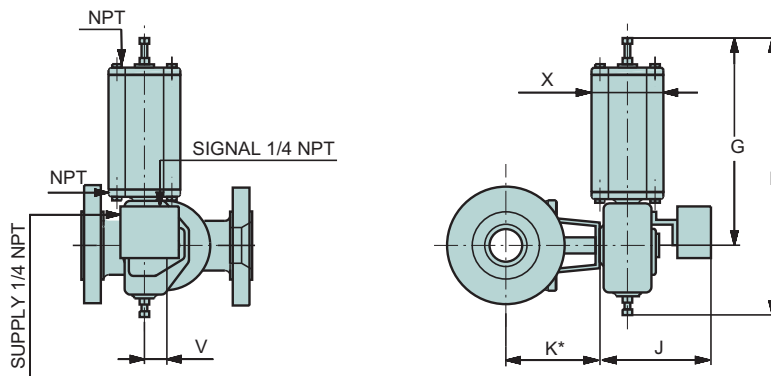

**VALVE + B1C ACTUATOR , DIMENSIONS, mm**

ACTUATOR	F	G	J	V	X	NPT	kg
B1C6	400	260	283	36	90	1/4	4,2
B1C9	455	315	279	43	110	1/4	9,6
B1C11	540	375	290	51	135	3/8	16
B1C13	635	445	316	65	175	3/8	31
B1C17	770	545	351	78	215	1/2	54
B1C20	840	575	385	97	215	1/2	73
B1C25	1040	710	448	121	265	1/2	131
B1C32	1330	910	525	153	395	3/4	256
B1C40	1660	1150	595	194	505	3/4	446
B1C50	1970	1350	690	242	610	1	830

**VALVE + B1J/B1JA ACTUATOR, DIMENSIONS, mm**

ACTUATOR	F	G	J	V	X	NPT	kg
B1J/B1JA6	485	368	273	36	110	3/8	13
B1J/B1JA8	560	420	279	43	135	3/8	17
B1J/B1JA10	650	490	290	51	175	3/8	30
B1J/B1JA12	800	620	316	65	215	1/2	57
B1J/B1JA16	990	760	351	78	265	1/2	100
B1J/B1JA20	1200	935	358	97	395	3/4	175
B1J/B1JA25	1530	1200	448	121	505	3/4	350
B1J/B1JA32	1830	1410	525	153	540	1	671

**VALVE + B1C ACTUATOR, DIMENSIONS, inch**

ACTUATOR	F	G	J	V	X	NPT	lbs
B1C6	15.75	10.24	11.14	1.42	3.54	1/4	9
B1C9	17.91	12.40	10.98	1.69	4.33	1/4	21
B1C11	21.26	14.76	11.42	2.01	5.31	3/8	35
B1C13	25.00	17.52	12.44	2.56	6.89	3/8	68
B1C17	30.31	21.46	13.82	3.07	8.46	1/2	119
B1C20	33.07	22.64	15.16	3.82	8.46	1/2	161
B1C25	40.94	27.95	17.64	4.76	10.43	1/2	288
B1C32	52.36	35.83	20.67	6.02	15.55	3/4	563
B1C40	65.35	45.28	23.43	7.64	19.88	3/4	981
B1C50	77.56	53.15	27.17	9.53	24.02	1	1826

**VALVE + B1J/B1JA ACTUATOR, DIMENSIONS, inch**

ACTUATOR	F	G	J	V	X	NPT	lbs
B1J/B1JA6	19.09	14.49	10.75	1.42	4.33	3/8	28
B1J/B1JA8	22.05	16.54	10.98	1.69	5.31	3/8	37
B1J/B1JA10	25.59	19.29	11.42	2.01	6.89	3/8	66
B1J/B1JA12	31.50	24.41	12.44	2.56	8.46	1/2	125
B1J/B1JA16	38.98	29.92	13.82	3.07	10.43	1/2	220
B1J/B1JA20	47.24	36.81	14.09	3.82	15.55	3/4	385
B1J/B1JA25	60.24	47.24	17.64	4.76	19.88	3/4	770
B1J/B1JA32	72.05	55.51	20.67	6.02	21.26	1	1476

\*) See K dimension from tables on pages 6 and 7.



## HOW TO ORDER

To specify a control valve, make a selection from each designation below. These codes create a complete valve model code. The valve model number expresses the standard product construction. An extensive range of unlisted options and variations are available. For options not shown, or to enter an order, contact your local Metso sales representative.

Example:

1.	2.	3.	4.	5.	6.	7.	8.	9.	10.	11.		
Q	-	T5	F	E	04	A	A	A	03	G	/	-

1. Sign	Trim options
Q	Low noise trim.
QA	Low noise trim + attenuator plate.
QX	Multichannel low noise trim.
Q2G-	Q2-trim for gas applications
QXA	Multichannel low noise trim + attenuator plate.
QXR	Reduced capacity multichannel low noise trim.
QRA	Reduced multichannel low noise trim + attenuator plate.
V--	V-port (only for T5/T4 1", 1 1/2", 2"/DN 25, 40, 50). See table on page 3.

2. Sign	Series
T5	Reduced bore 2" - 16", full bore 1" & 1 1/2", flanged.
T4	Reduced bore 2" - 16", full bore 1" & 1 1/2", weld-ends.

3. Sign	Pressure rating
D	ASME Class 300.
F	ASME Class 600.
M	PN 40.
N	PN 63.
P	PN 100.

4. Sign	Construction
E	PTFE bearings. Temperature range -50 ... +230 °C.
B	Metal bearings. Temperature range -50 ... +450 °C.
C	Cryogenic, metal or PTFE bearings F-seat only. Temperature below -50 °C.
Z	Oxygen construction BAM tested non-metallic materials - T = -50 ... +200 °C - Max pressure based on body rating - Metal bearings, cobalt based alloy - seat type F, WC-Co coated ball and seats (other seat types shall be consulted with Product Center) - Oxygen cleaning acc. to Metso internal procedure T-2115

5. Sign	Size (in inch)
	01, 1.5, 02, 03, 04, 06, 08, 10, 12, 14, 16.

6. Sign	Body	Studs
A	CF8M	B8M
D	WCB	L7M

7. Sign	Ball
A	CF8M + hard chrome with metal seats.
D	CF8M + NiBo.

8. Sign	Seat
A	Metal seat General service and fire safe applications.
E	Metal seat for control service. Ejector style seat, lower torque in modulating control.
F	Bellows seat Shut-off applications at low and high temperatures.
R	Soft seat Control and shut-off applications for high pressure gas.

9. Sign	Seat seal	Bonnet gasket	Gland packing	Seat	Construction	Bearing
02	Graphite	Graphite	Graphite	A, E1	E, C	PTFE
03	Graphite	Graphite	Graphite	A, F, E1	B, C	metal
63	Viton® GF	Graphite	Graphite	R	E, B	PTFE or metal

10. Sign	Gland packing options
G	Live loaded graphite packing
G1	Live loaded graphite packing, ISO 15848-1 certified

11. Sign	Flange facing
	Ra 3.2 - 6.3 / RMS 125 - 250
05	Ring joint.

Subject to change without prior notice.

**Metso Flow Control Inc.**

**Europe**, Vanha Porvoontie 229, P.O. Box 304, FI-01301 VANTAA, Finland.  
Tel. +358 20 483 150. Fax +358 20 483 151

**North America**, 44 Bowditch Drive, P.O. Box 8044, Shrewsbury, MA 01545, USA.  
Tel. +1 508 852 0200. Fax +1 508 852 8172

**South America**, Av. Independência, 2500- Iporanga, 18087-101, Sorocaba-São Paulo, Brazil.  
Tel. +55 15 2102 9700. Fax +55 15 2102 9748/49

**Asia Pacific**, Haw Par Centre #06-01, 180 Clemenceau Avenue, Singapore 239922.  
Tel. +65 6511 1011. Fax +65 6250 0830

**China**, 11/F, China Youth Plaza, No.19 North Rd of East 3rd Ring Rd, Chaoyang District,  
Beijing 100020, China. Tel. +86 10 6566 6600. Fax +86 10 6566 2583.

**Middle East**, Roundabout 8, Unit AB-07, P.O. Box 17175, Jebel Ali Freezone, Dubai,  
United Arab Emirates. Tel. +971 4 883 6974. Fax +971 4 883 6836

[www.metso.com/valves](http://www.metso.com/valves)

