

Type 2300

2/2-way angle-seat control valve
2/2-Wege-Schrägsitzregelventil
Vanne de réglage à siège incliné 2/2 voies

Operating Instructions

Bedienungsanleitung
Manuel d'utilisation



We reserve the right to make technical changes without notice.
Technische Änderungen vorbehalten.
Sous réserve de modifications techniques.

© Bürkert Werke GmbH & Co. KG, 2008 - 2018

Operating Instructions 1802/09_EU-ML_00805626 / Original DE

1	OPERATING INSTRUCTIONS	4	8	INSTALLATION	22
1.1	Symbols.....	4	8.1	Safety instructions.....	22
1.2	Definition of term / abbreviation.....	4	8.2	Before installation.....	23
2	INTENDED USE	5	8.3	Installation	24
3	BASIC SAFETY INSTRUCTIONS	5	8.4	Pneumatic connection.....	28
4	GENERAL INFORMATION	7	8.5	Start-up	29
4.1	Contact address.....	7	8.6	Removal	29
4.2	Warranty	7	9	ELECTRICAL CONTROL UNIT	29
4.3	Information on the internet	7	10	MAINTENANCE, CLEANING	30
5	PRODUCT DESCRIPTION	7	10.1	Safety instructions.....	30
5.1	General description	7	10.2	Maintenance work	30
5.2	Versions.....	7	10.3	Replacing the wearing parts.....	31
5.3	Properties	8	11	MALFUNCTIONS	40
5.4	Designated application area.....	9	12	REPLACEMENT PARTS	41
6	STRUCTURE AND FUNCTION	9	12.1	Replacement part sets	41
6.1	Structure.....	9	12.2	Installation tools	43
6.2	Function.....	10	13	PACKAGING, TRANSPORT, STORAGE	43
7	TECHNICAL DATA	12			
7.1	Conformity.....	12			
7.2	Standards.....	12			
7.3	Type label	12			
7.4	Operating conditions.....	12			
7.5	Flow values and characteristics	17			
7.6	General technical data.....	21			

1 OPERATING INSTRUCTIONS

The operating instructions describe the entire life cycle of the device. Keep these instructions in a location which is easily accessible to every user and make these instructions available to every new owner of the device.

The operating instructions contain important safety information!

Failure to observe these instructions may result in hazardous situations.

- ▶ The operating instructions must be read and understood.

1.1 Symbols



DANGER!

Warns of an immediate danger!

- ▶ Failure to observe the warning may result in a fatal or serious injury.



WARNING!

Warns of a potentially dangerous situation!

- ▶ Failure to observe the warning may result in serious injuries or death.



CAUTION!

Warns of a possible danger!

- ▶ Failure to observe this warning may result in a moderately severe or minor injury.

NOTE!

Warns of damage to property!

- ▶ Failure to observe the warning may result in damage to the device or the equipment.



Indicates important additional information, tips and recommendations.



Refers to information in these operating instructions or in other documentation.

- ▶ designates instructions for risk prevention.
- Designates a procedure which you must carry out.

1.2 Definition of term / abbreviation

The term “device” used in these instructions always stands for the angle-seat control valve Type 2300.

The abbreviation “Ex” used in these instructions always stands for “explosion-protected”.

2 INTENDED USE

Non-intended use of the angle-seat control valve Type 2300 may be a hazard to people, nearby equipment and the environment.

- ▶ The device is designed for the controlled flow of liquid and gaseous media. Operation is possible only in combination with a suitable control unit.
- ▶ In the potentially explosion-risk area the globe valve type 2300 may be used only according to the specification on the separate Ex type label. For use observe the additional information enclosed with the device together with safety instructions for the explosion-risk area.
- ▶ Devices without a separate Ex type label may not be used in a potentially explosive area.
- ▶ The admissible data, the operating conditions and conditions of use specified in the contract documents, operating instructions and on the type label are to be observed during use. These are described in the chapter entitled "[7 Technical data](#)".
- ▶ Protect device from damaging environmental influences (e.g. radiation, humidity, steam, etc.). If anything is unclear, consult the relevant sales office.
- ▶ The device may be used only in conjunction with third-party devices and components recommended and authorized by Bürkert.
- ▶ Correct transportation, correct storage and installation and careful use and maintenance are essential for reliable and faultless operation.
- ▶ Use the device only as intended.

3 BASIC SAFETY INSTRUCTIONS

These safety instructions do not make allowance for any

- contingencies and events which may arise during the installation, operation and maintenance of the devices.
- local safety regulations; the operator is responsible for observing these regulations, also with reference to the installation personnel.



DANGER!

Risk of injury from high pressure in the equipment or device!

- ▶ Before working on equipment or device, switch off the pressure and deaerate or drain lines.

Risk of injury from electric shock (when electrical component installed).

- ▶ Before reaching into the device, switch off the power supply and secure to prevent reactivation!
- ▶ Observe applicable accident prevention and safety regulations for electrical equipment!



WARNING!

Risk of injury when opening the actuator!

The actuator contains a tensioned spring. If the actuator is opened, there is a risk of injury from the spring jumping out!

- ▶ The actuator must not be opened.

Risk of injury from moving parts in the device!

- ▶ Do not reach into openings.

Danger due to loud noises.

- ▶ Depending on the operating conditions, the device may generate loud noises. More detailed information on the likelihood of loud noises is available from the relevant sales office.
- ▶ Wear hearing protection when in the vicinity of the device.



CAUTION!

Risk of burns!

The surface of the device may become hot during long-term operation.

- ▶ Do not touch the device with bare hands.

Leaking medium when the packing gland is worn.

- ▶ Regularly check relief bore for leaking medium.
- ▶ If the media is hazardous, protect the area surrounding the discharge point against dangers.

General hazardous situations.

To prevent injury, ensure that:

- ▶ That the system cannot be activated unintentionally.
- ▶ Installation and repair work may be carried out by authorized technicians only and with the appropriate tools.
- ▶ After an interruption in the power supply or pneumatic supply, ensure that the process is restarted in a defined or controlled manner.
- ▶ The device may be operated only when in perfect condition and in consideration of the operating instructions.
- ▶ Observe the safety regulations specific to the plant for application planning and operation of the device.
- ▶ The plant operator is responsible for the safe operation and handling of the plant.
- ▶ The general rules of technology apply to application planning and operation of the device.

To prevent damage to property of the device, ensure:

- ▶ Supply the media connections only with those media which are specified as flow media in the chapter entitled "7 Technical data".
- ▶ Do not put any loads on the valve (e.g. by placing objects on it or standing on it).
- ▶ Do not make any external modifications to the valves. Do not paint the body parts or screws.
- ▶ Do not transport, install or remove heavy devices without the aid of a second person and using suitable auxiliary equipment.
- ▶ The exhaust air may be contaminated with lubricants in the actuator.

4 GENERAL INFORMATION

4.1 Contact address

Germany

Bürkert Fluid Control System
Sales Centre
Christian-Bürkert-Str. 13-17
D-74653 Ingelfingen
Tel. + 49 (0) 7940 - 10 91 111
Fax + 49 (0) 7940 - 10 91 448
E-mail: info@burkert.com

International

Contact addresses are found on the final pages of the printed operating manual.

You can also find information on the Internet under:

www.burkert.com

4.2 Warranty

The warranty is only valid if the device is used as authorized in accordance with the specified application conditions.

4.3 Information on the internet

The operating instructions and data sheets for Type 2300 can be found on the Internet at: www.burkert.com

5 PRODUCT DESCRIPTION

5.1 General description

The 2/2-way angle-seat control valve Type 2300 is suitable for liquid and gaseous media.

It uses neutral gases or air (control media) to control the flow of water, alcohol, oil, fuel, hydraulic fluid, saline solution, lye, organic solvent and steam (flow media).

The operation of the angle-seat control valve Type 2300 is possible only in combination with an control unit. Possible control units are:

Positioner Type 8692, 8694 and 8696
Process controller Type 8693

5.2 Versions

There are 2 versions of the angle-seat control valve Type 2300.

- Standard version – **without** separate Ex type label.
The standard version must not be used in the potentially explosive area.
- Ex version – **with** separate Ex type label.
The Ex version may be used in the potentially explosive area. In doing so, observe the specifications on the separate Ex type label and the additional information enclosed with the device together with safety instructions for the Ex area.

5.3 Properties

- Direct installation of the positioners Type 8692 / 8694 / 8696 or the process controller Type 8693.
- High tightness by self-adjusting packing glands (spindle sealing element).
- Closes tightly when using the PTFE control cone.
- High flow values by the streamlined valve body made of stainless steel.
- Simple and fast replacement of the control cone.
- Actuator can be rotated steplessly through 360°.
- Maintenance-free under normal conditions.

5.3.1 Technical features

- Characteristic: modified equal-percentage flow characteristic.
- Theoretical setting ratio (Kv_S / Kv_0) 50:1; alternatively, other setting ratios can be realized.
- Kv_R value, i.e. the smallest Kv value at which the angularity tolerance according to DIN IEC 534-2-4 is still maintained:
 - ≤ DN20 Kv_R at 10 % of the stroke
 - > DN20 Kv_R at 5 % of the stroke

5.3.2 Options

Control unit: Depending on the requirement, control units in various designs are available.

- Positioner Type 8692, 8694 and 8696
- Process controller Type 8693

- Vacuum
- Food conformity FDA
- DVGW
- ATEX

5.3.3 Device versions

Pilot pressure

Designs with lower pilot pressure (reduced spring force) are available on request.

Contact your Bürkert sales office or our Sales Centre.
E-mail: info@de.buerkert.com

Actuator sizes

Depending on the orifice, the angle-seat control valve is available for the following actuator sizes:

Orifice DN	Available actuator size \varnothing [mm]			
15	50	70	-	-
20	50	70	-	
25	50	70	90	-
32	-	70	90	
40		90	130	
50		-	90	130
65		-	-	130

Tab. 1: Actuator sizes

5.4 Designated application area



Observe the maximum pressure range according to the type label!

- Neutral gases and liquids up to 16 bar.
- Steam up to 11 bar absolute / 185 °C for seat seal steel / steel.
Steam up to 2.7 bar absolute / 130 °C for seat seal PTFE / steel.
- Aggressive media.

5.4.1 Application areas

- e.g.
- Plant construction
 - Food processing
 - Chemical engineering
 - Sterilizer construction, temperature control
 - Gas dosing
 - Conveyor systems for various bulk material (also sensitive foodstuff)

6 STRUCTURE AND FUNCTION



The operation of the angle-seat control valve Type 2300 is possible only in combination with a control unit.

Possible control units are:
Positioner Type 8692, 8694 and 8696
Process controller Type 8693

6.1 Structure

The angle-seat control valve consists of a pneumatically operated piston actuator, a control cone and a 2/2-way angle-seat body.

Via a dowel pin, the control cone is modularly coupled to the actuator spindle for quick changeovers.

For the body, almost any line connections are possible. A threaded port and a welded end are offered as a standard version.

The valve seats are incorporated directly. The flow inlet is always under seat.



The description of the control function (CF) can be found in chapter entitled "[6.2.1 Control functions \(CF\)](#)".

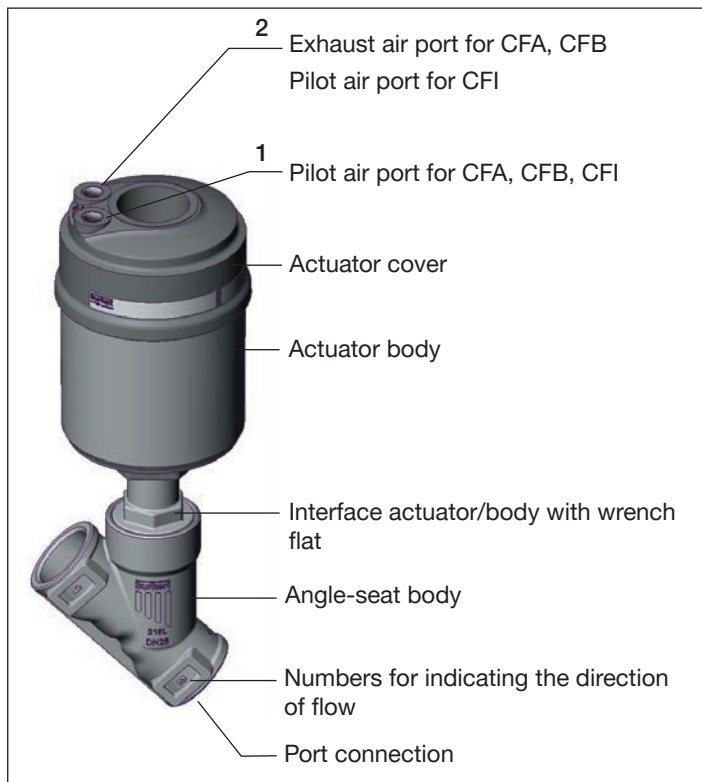

Fig. 1: Angle-seat control valve Type 2300, structure and description

6.2 Function

The seat of the valve is always closed against the medium flow. Spring force (CFA) or pneumatic pilot pressure (CFB and CFI) generates the closing force on the control cone. The force is transferred via a spindle which is connected to the actuator piston.

6.2.1 Control functions (CF)



WARNING!

For control function I – Danger if pilot pressure fails!

For control function I control and resetting occur pneumatically. If the pressure fails, no defined position is reached.

- ▶ To ensure a controlled restart, first pressurize the device with pilot pressure, then switch on the medium.

Control function A (CFA)

Normally closed by spring action.

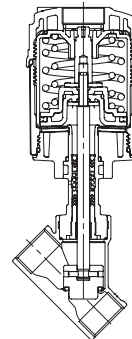
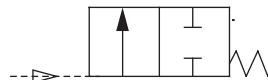

Control function B (CFB)

Normally open by spring action.

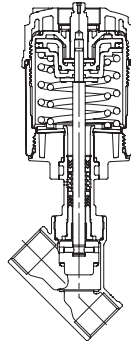
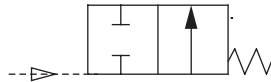

Control function I (CFI)

Actuating function via reciprocal pressurization.

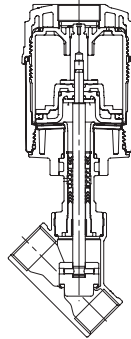
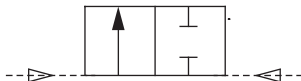

6.2.2 Flow direction below the seat

Depending on the version, the valve is closed against the medium flow with spring force (control function A, CFA) or with pilot pressure (control function B or I, CFB or CFI). As the medium pressure is under the control cone, this pressure contributes to the opening of the valve.



WARNING!

Medium may be discharged if minimum pilot pressure is too low or medium pressure too high!

If the minimum pilot pressure is too low for CFB and CFI or the permitted medium pressure is exceeded, leaks may occur.

- ▶ Observe minimum pilot pressure.
- ▶ Do not exceed medium pressure.
- ▶ See chapter entitled "[7.4.3 Pressure ranges](#)".

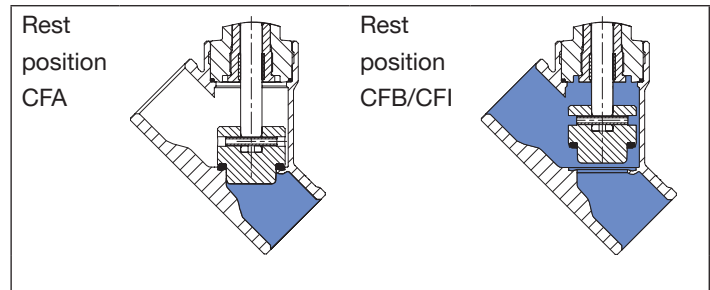

Fig. 2: Flow direction below the seat
(Rest open/closed, closing against medium)

7 TECHNICAL DATA

7.1 Conformity

Type 2300 conforms with the EU Directives according to the EU Declaration of Conformity.

7.2 Standards

The applied standards, which verify conformity with the EU Directives, can be found on the EU-Type Examination Certificate and / or the EU Declaration of Conformity.

According to Pressure Equipment Directive the following operating conditions must be observed:

Line connection orifice	Maximum pressure for compressible fluids of Group 1 (hazardous gases and vapors according to Art. 3 No. 1.3 Letter a first dash)
DN65	15 bar

7.3 Type label

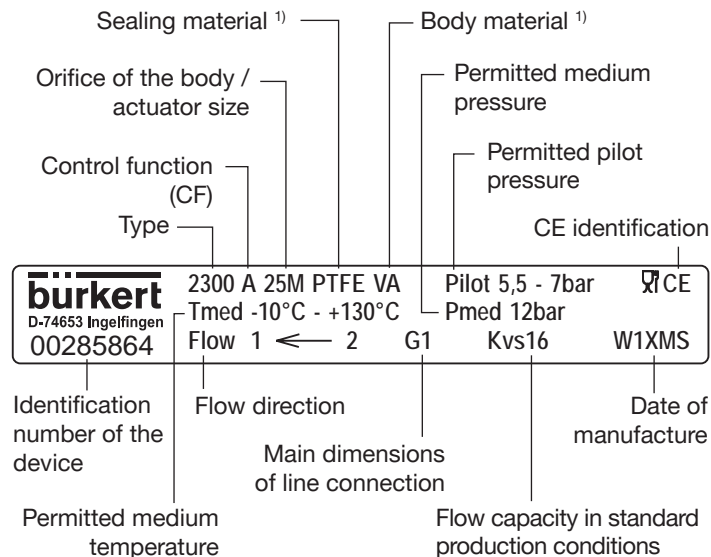

1) For description of versions see ["7.6 General technical data"](#)

7.4 Operating conditions



Observe permitted ranges on the type label of the device!

7.4.1 Temperature ranges

Actuator size [mm]	Actuator material	Medium		Environ-ment ²⁾
		Seat seal steel / steel	Seat seal PTFE / steel	
ø 50	PPS	-10...+185°C	-10...+130°C	-10...+60°C ³⁾ -10...+100°C ⁴⁾
ø 70				
ø 90				
ø 130				

Tab. 2: Temperature ranges



2) If a pilot valve/control unit is used, the max. ambient temperature is +55 °C.



The angle-seat control valve is suitable for steam sterilization.

7.4.2 Control medium

In conjunction with pneumatic control units (positioner or process controllers), pilot air according to DIN ISO 8573-1 must be used:

- Class 3 (for water content)
- Class 5 (for dust and oil content).



The specification is described in detail in the operating instructions of the respective positioner / process controller in the chapter entitled “Technical data”.

7.4.3 Pressure ranges

Pilot pressure range⁵⁾ on controlled operation

Actuator size	Orifice DN [mm]	Pilot pressure range ⁵⁾ [bar]	
		CFA	CFB
ø 50 mm	15 – 25	3.4 – 5.5	3.3 – 5.1
ø 70 mm	15 – 32	2.6 – 5.5	2.6 – 5.2
ø 90 mm	25 – 50	3.3 – 5.5	1.8 – 2.5
ø 130 mm	40 – 50	3.3 – 5.6	1.9 – 2.7
	65	4.6 – 5.6	1.9 – 2.7

Tab. 3: Pilot pressure range on controlled operation



5) To ensure reliable operation with pneumatic control units (positioner or process controller), observe the permitted minimum and maximum pilot pressure!

3) Pilot air ports with push-in connector
4) Pilot air ports with threaded bushing.

Maximum pilot pressure for valves without pneumatic control unit

Actuator size	Actuator material	max. permitted pilot pressure ⁶⁾
ø 50 mm	PPS	10 bar
ø 70 mm		
ø 90 mm		
ø 130 mm		7 bar

Tab. 4: Pilot pressure for valves without pneumatic control unit



6) Observe the maximum pressure range according to the type label!

Operating pressure for control function A⁷⁾

Actuator size	Orifice DN [mm]	Required pilot pressure [bar]	Max. sealed medium pressure [bar]
ø 50 mm	15	5.5	16
	20	5.5	10
	25	5.5	5
ø 70 mm	15	5.5	16
	20	5.5	16
	25	5.5	12
	32	5.5	6
ø 90 mm	25	5.5	16
	32	5.5	16
	40	5.5	12
	50	5.5	7
ø 130 mm	40	5.5	16
	50	5.5	16
	65	5.6	16 (15*)

Tab. 5: Operating pressure for control function A

* According to Pressure Equipment Directive for compressible fluids of Group 1 (hazardous gases and vapors according to Art. 3 No. 1.3 Letter a first dash)

7) The description of the control function (CF) can be found in chapter entitled "6.2.1 Control functions (CF)".

Pilot pressure for control function B⁸⁾

Actuator size	Orifice DN [mm]	Pilot pressure [bar]		Max. permitted medium pressure [bar]
		for medium pressure 0 bar	max	
ø 50 mm	15	4.6	6.6	16
	20	5.1	7.0	9
	25	5.1	7.0	5
ø 70 mm	15	4.4	5.3	16
	20	5.2	6.8	16
	25	5.2	7.0	12
	32	5.2	7.0	6
ø 90 mm	25	2.4	4.2	16
	32	2.4	5.3	16
	40	2.5	6.5	16
ø 130 mm	50	2.5	7.0	14
	40	2.7	4.5	16
	50	2.7	5.6	16
	65	2.7	7.0	16 (15*)

Tab. 6: Pilot pressure for control function B

* According to Pressure Equipment Directive for compressible fluids of Group 1 (hazardous gases and vapors according to Art. 3 No. 1.3 Letter a first dash)



Designs with lower pilot pressure (reduced spring force) are available on request.

8) The description of the control function (CF) can be found in chapter entitled "6.2.1 Control functions (CF)".

Required minimum pilot pressure depending on medium pressure for circuit function B

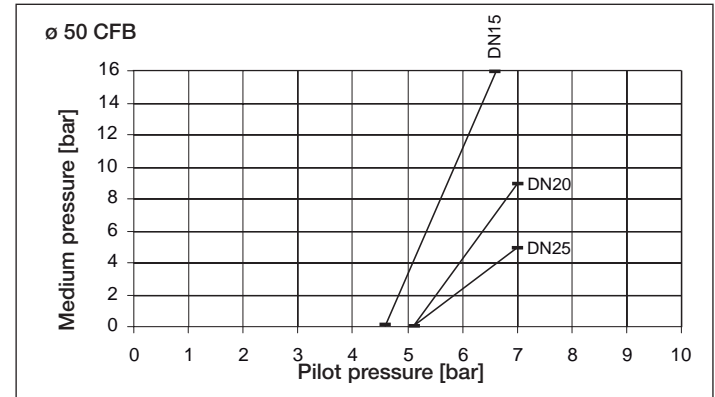

Fig. 3: Pressure graph, actuator ø 50 mm, control function B

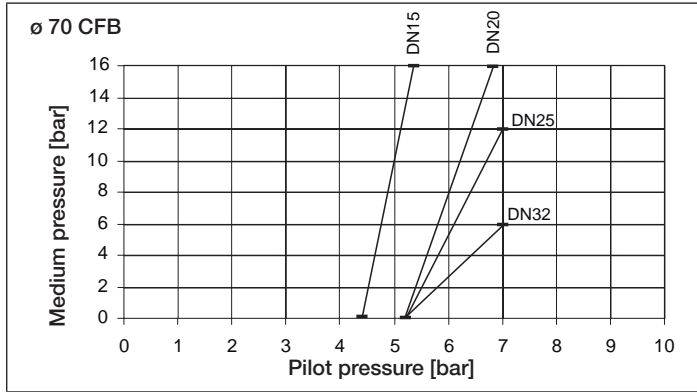

Fig. 4: Pressure graph, actuator ø 70 mm, control function B

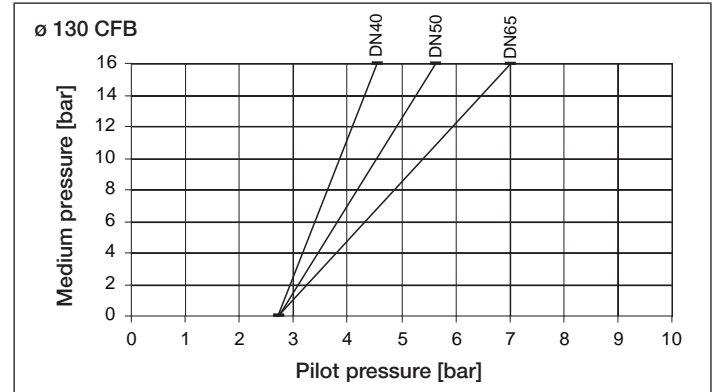

Fig. 6: Pressure graph, actuator ø 130 mm, control function B

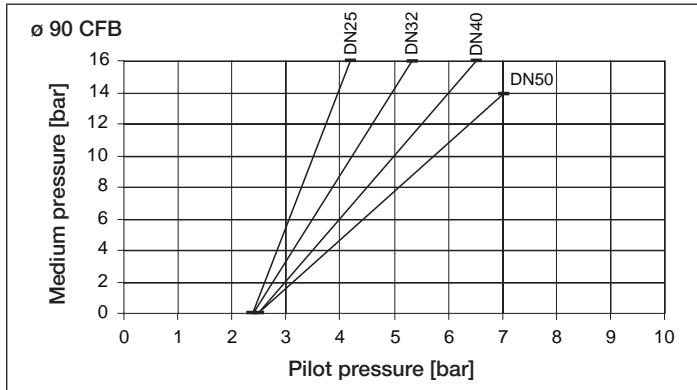

Fig. 5: Pressure graph, actuator ø 90 mm, control function B

7.5 Flow values and characteristics

Flow values for DN15

Stroke [%]	Kv value [m ³ /h]	Stroke [%]	Kv value [m ³ /h]
5	0.16	60	3.5
10	0.17	70	4.0
20	0.22	80	4.5
30	0.4	90	4.8
40	1.2	100	5.0
50	2.7		

Tab. 7: Flow values for DN15

Flow characteristics for DN15

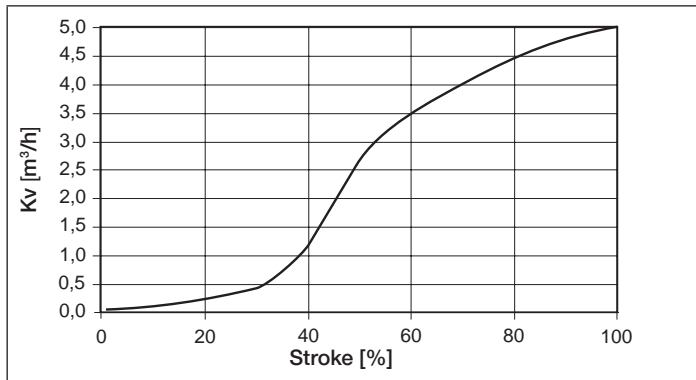

Fig. 7: Flow characteristics for DN15

Flow values for DN20

Stroke [%]	Kv value [m ³ /h]	Stroke [%]	Kv value [m ³ /h]
5	0.26	60	7.2
10	0.27	70	8.3
20	0.4	80	9.1
30	1.1	90	9.6
40	4.0	100	10.0
50	5.9		

Tab. 8: Flow values for DN20

Flow characteristics for DN20

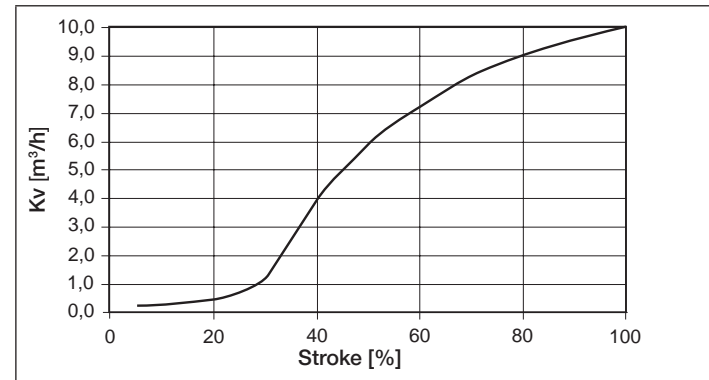

Fig. 8: Flow characteristics for DN20

Flow values for DN25

Stroke [%]	Kv value [m³/h]	Stroke [%]	Kv value [m³/h]
5	0.34	60	11.5
10	0.36	70	13.0
20	0.62	80	14.2
30	1.5	90	15.4
40	5.2	100	16.0
50	8.9		

Tab. 9: Flow values for DN25

Flow characteristics for DN25

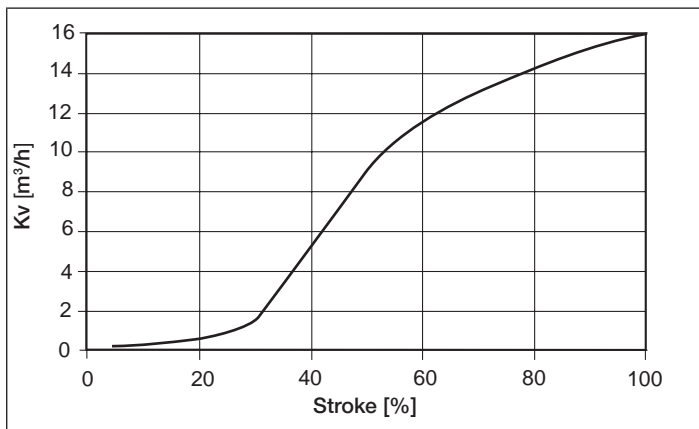

Fig. 9: Flow characteristics for DN25

Flow values for DN32

Stroke [%]	Kv value [m³/h]	Stroke [%]	Kv value [m³/h]
5	0.43	60	13.8
10	0.52	70	16.4
20	0.82	80	19.2
30	1.4	90	21.3
40	4.0	100	23.0
50	9.3		

Tab. 10: Flow values for DN32

Flow characteristics for DN32

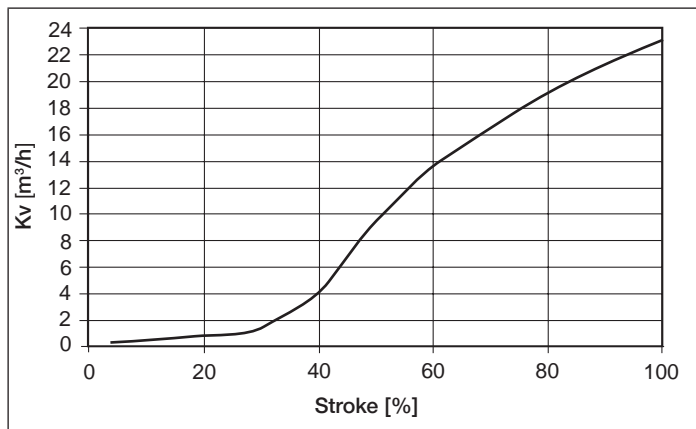

Fig. 10: Flow characteristics for DN32

Flow values for DN40 - Actuator size \varnothing 90

Stroke [%]	Kv value [m ³ /h]	Stroke [%]	Kv value [m ³ /h]
5	0.47	60	21.5
10	0.62	70	25.3
20	1.1	80	28.8
30	2.6	90	31.6
40	10.0	100	34.0
50	17.0		

Tab. 11: Flow values for DN40 - Actuator size \varnothing 90

Flow characteristics for DN40 - Actuator size \varnothing 90

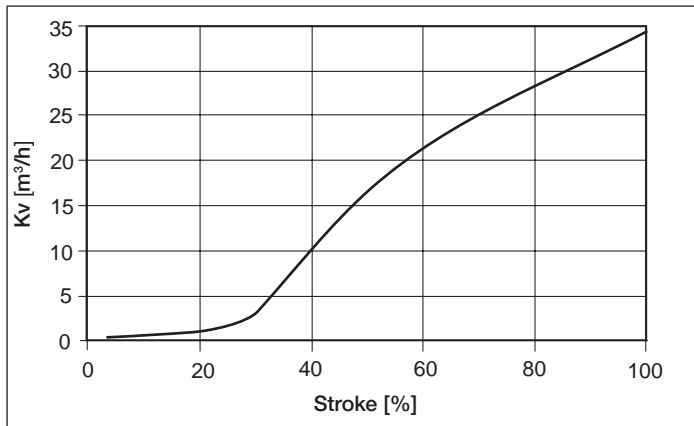

Fig. 11: Flow characteristics for DN40 - Actuator size \varnothing 90

Flow values for DN40 - Actuator size \varnothing 130

Stroke [%]	Kv value [m ³ /h]	Stroke [%]	Kv value [m ³ /h]
5	0.48	60	24.3
10	0.66	70	28.3
20	1.4	80	31.7
30	5.1	90	34.5
40	14.0	100	36.0
50	20.0		

Tab. 12: Flow values for DN40 - Actuator size \varnothing 130

Flow characteristics for DN40 - Actuator size \varnothing 130

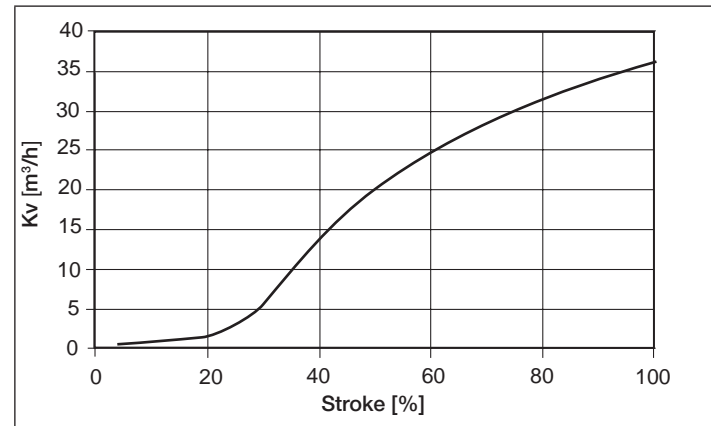

Fig. 12: Flow characteristics for DN40 - Actuator size \varnothing 130

Flow values for DN50 - Actuator size \varnothing 90

Stroke [%]	Kv value [m ³ /h]	Stroke [%]	Kv value [m ³ /h]
5	0.85	60	28.6
10	1.1	70	35.6
20	1.6	80	40.6
30	2.7	90	45.0
40	10.2	100	49.0
50	20.0		

Tab. 13: Flow values for DN50 - Actuator size \varnothing 90

Flow characteristics for DN50 - Actuator size \varnothing 90

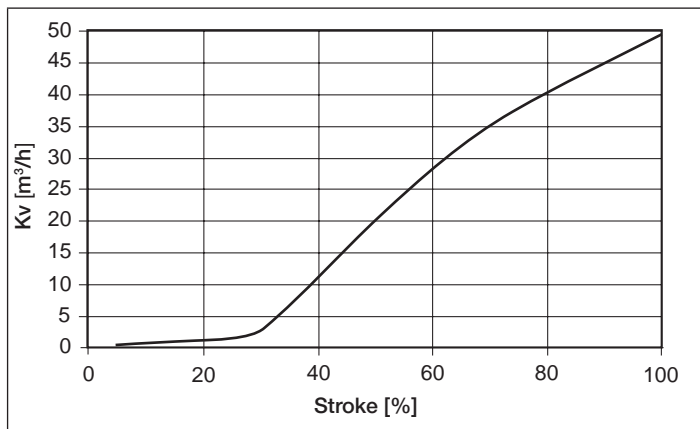

Fig. 13: Flow characteristics for DN50 - Actuator size \varnothing 90

Flow values for DN50 - Actuator size \varnothing 130

Stroke [%]	Kv value [m ³ /h]	Stroke [%]	Kv value [m ³ /h]
5	0.87	60	35.0
10	1.2	70	40.3
20	1.8	80	45.0
30	4.0	90	48.0
40	15.2	100	53.0
50	26.0		

Tab. 14: Flow values for DN50 - Actuator size \varnothing 130

Flow characteristics for DN50 - Actuator size \varnothing 130

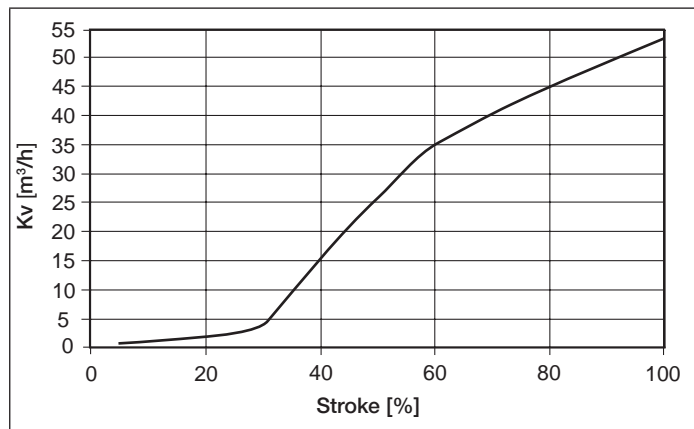

Fig. 14: Flow characteristics for DN50 - Actuator size \varnothing 130

Flow values for DN65 - Actuator size \varnothing 130

Stroke [%]	Kv value [m ³ /h]	Stroke [%]	Kv value [m ³ /h]
5	1.7	60	58.0
10	2.0	70	67.0
20	6.5	80	75.0
30	20.0	90	83.0
40	35.0	100	90.0
50	48.0		

Tab. 15: Flow values for DN65 - Actuator size \varnothing 130

Flow characteristics for DN65 - Actuator size \varnothing 130

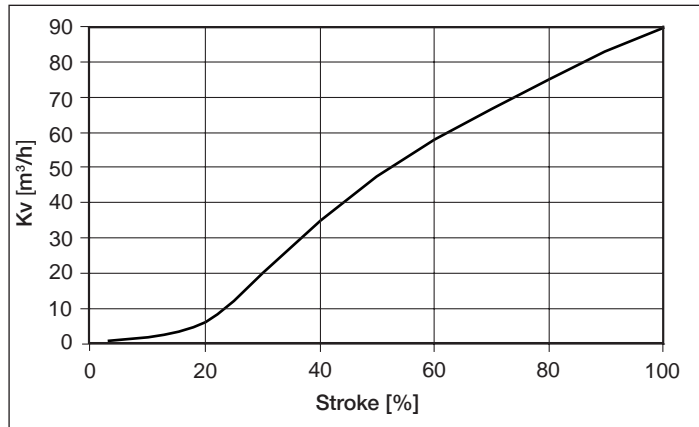

Fig. 15: Flow characteristics for DN65 - Actuator size \varnothing 130

7.6 General technical data

Control functions (CF) The valve seat is always closed against the medium flow

Control function A Normally closed by spring action

Control function B Normally open by spring action

Control function I Actuating function via reciprocal pressurization
 (not for actuator size \varnothing 50 mm in combination with Type 8696)

Actuator sizes \varnothing 50 mm
 \varnothing 70 mm
 \varnothing 90 mm
 \varnothing 130 mm

Materials

Valve body 316L

Actuator PPS and stainless steel

Sealing elements FKM and EPDM

Spindle sealing PTFE V rings with spring compensation (with silicone grease)

Control cone Control cone with PTFE seal
 Steel / steel seal

Spindle	1.4401 / 1.4404
Spindle guide	1.4401 / 1.4404 / 316L
Connections	
Pilot air port	prepared for direct connection
Medium connection	Threaded port: G ½ – G 2 ½ (NPT, RC on request) Welded connection: as per EN ISO 1127 (ISO 4200), DIN 11850 R2 Other connections on request
Media	
Control medium	neutral gases, air
Flow media	Water, Alcohol, Fuel, Hydraulic liquids, Saline solutions, Lyes, Organic solvents
Installation position	as required, preferably with actuator in upright position
Protection class	IP67 in accordance with IEC 529/EN 60529

8 INSTALLATION

8.1 Safety instructions



DANGER!

Danger – high pressure in the equipment!

- ▶ Before loosening the lines and valves, turn off the pressure and vent the lines.



WARNING!

Risk of injury from improper installation!

- ▶ Installation may be carried out by authorised technicians only and with the appropriate tools!

Risk of injury from unintentional activation of the system and an uncontrolled restart!

- ▶ Secure system from unintentional activation.
- ▶ Following assembly, ensure a controlled restart.

For control function I – Danger if pilot pressure fails!

For control function I control and resetting occur pneumatically.

If the pressure fails, no defined position is reached.

- ▶ To ensure a controlled restart, first pressurize the device with pilot pressure, then switch on the medium.

Risk of injury from moving parts in the device!

- ▶ Do not reach into openings.



CAUTION!

Risk of injury due heavy devices!

- ▶ During transport or during assembly, a heavy device may fall and cause injury.
- ▶ Do not transport, install or remove heavy devices without the aid of a second person and using suitable auxiliary equipment.
- ▶ Use appropriate tools.

8.2 Before installation

- The angle-seat control valve can be installed in any installation position, preferably with the actuator in upright position.
- Before connecting the valve, ensure the pipelines are flush.
- Make certain the flow direction is correct (Flow direction always below seat).

8.2.1 Preparatory work

- Clean pipelines (Sealing material, swarf, etc.).

Devices with welded body

NOTE!

For valves with installed control:

When welding the valve body into the pipeline, the control must not be installed.

- ▶ Remove control from the actuator described below.

Remove the control unit from the actuator (if present):

- Clamp the valve body in a holding device.
- Loosen the fastening screws (2x).
- Remove the control unit upwards.

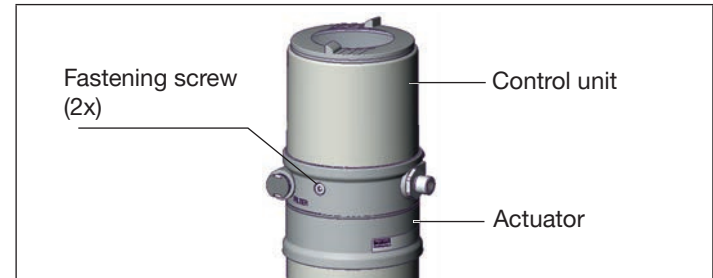

Fig. 16: Disassembly the control unit

Remove the actuator from the valve body.

- Install collet (white grommet) in pilot air port 1.

NOTE!

Damage to the seat seal or the seat contour!

- ▶ When removing the actuator, ensure that the valve is in open position.
- Control function A pressurize the pilot air port 1 with compressed air (5 bar): valve opens.
- Using a suitable open-end wrench, place the wrench flat on the pipe.

→ Unscrew the actuator from the valve body.

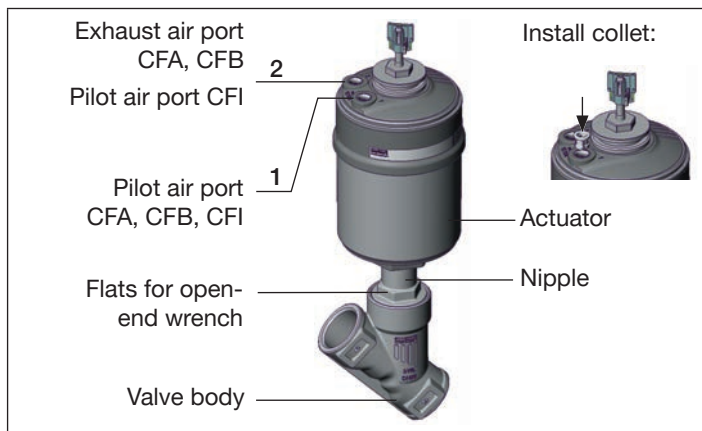

Fig. 17: Installation

Other device versions

- Do not remove actuator unless this is a customer-specific requirement.
- Procedure see [“Devices with welded body”](#).

8.3 Installation



WARNING!

Risk of injury from improper installation!

Assembly with unsuitable tools or non-observance of the tightening torque is dangerous as the device may be damaged.

- ▶ For installation use an open-end wrench, never a pipe wrench.
- ▶ Observe the tightening torque (see [“Tab. 16: Tightening torques of valve body / nipples”](#)).

Dirt trap for devices with authorisation in accordance with DIN EN 161

In accordance with DIN EN 161 “Automatic shut-off valves for gas burners and gas appliances” a dirt trap must be connected upstream of the valve and prevent the insertion of a 1 mm plug gauge.

- If the authorisation also applies to stainless steel bodies, the same type of dirt trap must be attached in front of the angle-seat control valve.

8.3.1 Installation of the valve body

Welded bodies

→ Weld valve body in pipeline system.

Other body versions

→ Connect body to pipeline.

8.3.2 Install actuator (welded body)

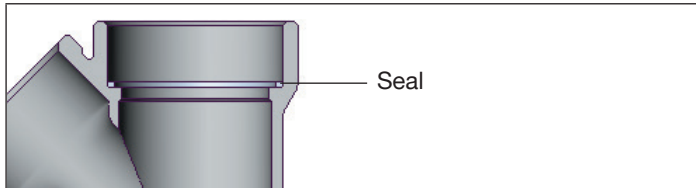

Fig. 18: Seal

→ Check the seal and if required, replace it.



WARNING!

Danger if incorrect lubricants used!

Unsuitable lubricant may contaminate the medium. In oxygen applications there is a risk of an explosion!

▶ In specific applications, e.g. oxygen or analysis applications, use appropriately authorized lubricants only.

→ Grease nipple thread before re-installing the actuator (e.g. with Klüber paste UH1 96-402 from Klüber).

NOTE!

Damage to the seat seal or the seat contour!

▶ When installing the actuator, ensure that the valve is in open position.

→ Control function A pressurize the pilot air port 1 with compressed air (5 bar): valve opens.

→ Screw actuator into the valve body. Observe tightening torque (see "Tab. 16").

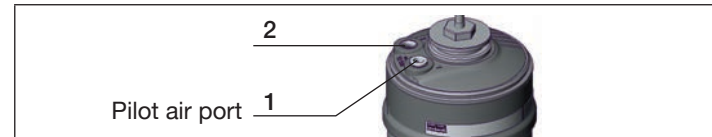

Fig. 19: Connections

Tightening torques of valve body / nipples

DN	Tightening torque [Nm]
15	45 ±3
20	50 ±3
25	60 ±3
32	65 ±3
40	
50	70 ±3
65	100 ±3

Tab. 16: Tightening torques of valve body / nipples

8.3.3 Install control unit



Before installation, check the position of the ports on the control unit and, if required, align the actuator. Description see chapter “8.3.4 Rotating the actuator”.

- Remove collet from pilot air port 1.
- Check that the O-rings are correctly positioned in the pilot air ports.
- Align the puck holder and the control unit until
 1. the puck holder can be inserted into the guide rail of the control unit and
 2. the supports of the control unit can be inserted into the pilot air ports of the actuator (see also “Fig. 21”).

NOTE!

Damaged printed circuit board or malfunction!

- ▶ Ensure that the puck holder is situated flat on the guide rail.

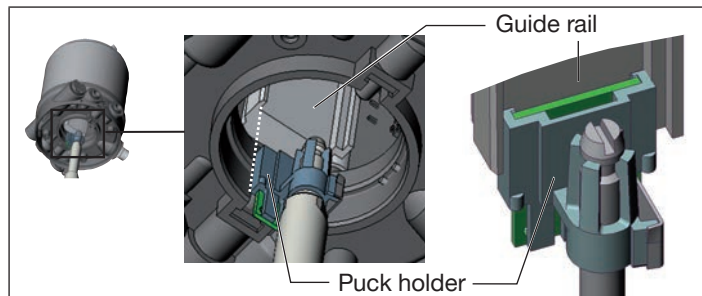

Fig. 20: Aligning the puck holder

- Push the control unit, without turning it, onto the actuator until no gap is visible on the form seal.

NOTE!

Too high torque when screwing in the fastening screw does not ensure protection class IP65 / IP67!

- ▶ The fastening screws may be tightened to a maximum torque of 1.5 Nm only.
- Attach the control unit to the actuator using the two side fastening screws. In doing so, tighten the screws only hand-tight (max. torque: 1.5 Nm).

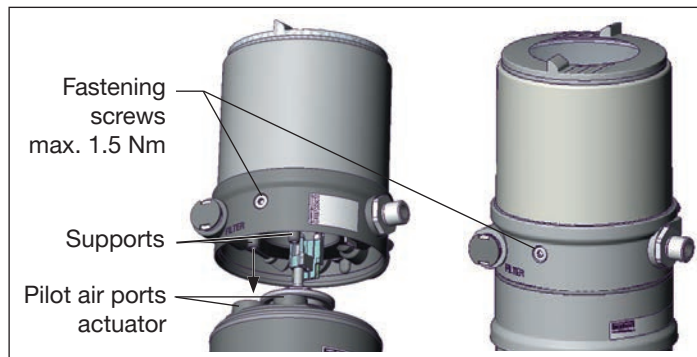

Fig. 21: Install control unit

8.3.4 Rotating the actuator

The position of the connections can be aligned steplessly by rotating the actuator through 360°.



Only the entire actuator can be rotated. The control unit cannot be rotated contrary to the actuator.

NOTE!

Damage to the seat seal or the seat contour!

- ▶ When rotating the actuator, ensure that the valve is in open position.

Procedure:

- Clamp the valve body in a holding device (applies only to valves which have not yet been installed).
- **Control function A:**
Without unit control: pressurize the pilot air port 1 with compressed air (5 bar): valve opens.
With unit control: open the valve according to the operating instructions for the control unit.
- Counter on the flats of the nipple with a suitable open-end wrench.



WARNING!

Risk of injury from discharge of medium and pressure!

If the direction of rotation is wrong, the body interface may become detached.

- ▶ Rotate the actuator module in the specified direction only (see [“Fig. 22”](#))!

Actuator with hexagon:

- Place suitable open-end wrench on the hexagon of the actuator.
- Rotate counter-clockwise (as seen from below) to bring the actuator into the required position.

Actuator without hexagon:

- Fit special wrench⁹⁾ exactly into the wrench contour on the underside of the actuator.
- Rotate clockwise (as seen from below) to bring the actuator into the required position.

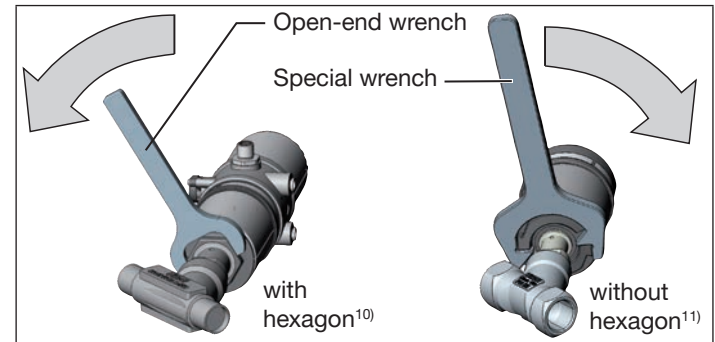

Fig. 22: Rotating with special key / open-end wrench

9) The special key (identification number 00 665 702) is available from your Bürkert sales office.

10) Series production status since middle of 2011

11) Series production status up to middle of 2011.

8.4 Pneumatic connection

DANGER!

Danger – high pressure in the equipment!

- ▶ Before loosening the lines and valves, turn off the pressure and vent the lines.

WARNING!

Risk of injury from unsuitable connection hoses!

Hoses which cannot withstand the pressure and temperature range may result in hazardous situations.

- ▶ Use only hoses which are authorized for the indicated pressure and temperature range.
- ▶ Observe the data sheet specifications from the hose manufacturers.

For control function I – Danger if pilot pressure fails!

For control function I control and resetting occur pneumatically.

If the pressure fails, no defined position is reached.

- ▶ To ensure a controlled restart, first pressurize the device with pilot pressure, then switch on the medium.

 The pneumatic connection of the angle-seat control valve can be carried out only in connection with the appropriate control unit.

Possible control units are:

Positioner Type 8692, 8694 and 8696

Process controller Type 8693

8.4.1 Connection of the control medium

- Connect the control medium to the pilot air port (1) (3 – 7 bar; instrument air, free of oil, water and dust).
- Fit the exhaust line or a silencer to the exhaust air port (3) and, if available, to the exhaust air port (3.1).



If used in an aggressive environment, we recommend conveying all free pneumatic connections into a neutral atmosphere with the aid of a pneumatic hose.

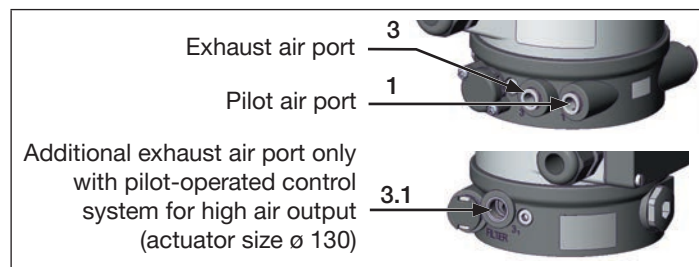

Fig. 23: Pneumatic connection

Control air hose:

6/4 mm or 1/4" pilot air hoses can be used.
A pilot air port via G 1/8 thread is available as an option.

8.5 Start-up

After installing the device, run the *X.TUNE* function. This function presets the control parameters.



Description – see operating instructions for the control.

8.6 Removal



DANGER!

Risk of injury from discharge of medium and pressure!

It is dangerous to remove a device which is under pressure due to the sudden release of pressure or discharge of medium.

- ▶ Before removing a device, switch off the pressure and vent the lines.

Procedure:

- Loosen the pneumatic connection.
- Remove the device.

9 ELECTRICAL CONTROL UNIT

The valve Type 2300 can be combined with following control units:

- Type 8692 Positioner
- Type 8694 Positioner
- Type 8696 Positioner
- Type 8693 Process controller



The electrical connection of the pilot valve or the control unit is described in the respective operating instructions for the pilot valve/control unit in the chapter titled [“Installation”](#).

10 MAINTENANCE, CLEANING

10.1 Safety instructions



DANGER!

Danger – high pressure in the equipment!

- ▶ Before loosening the lines and valves, turn off the pressure and vent the lines.

Risk of injury due to electrical shock!

- ▶ Before reaching into the system, switch off the power supply and secure to prevent reactivation!
- ▶ Observe applicable accident prevention and safety regulations for electrical equipment!



WARNING!

Risk of injury from improper maintenance!

- ▶ Maintenance may be performed by authorised technicians only!
- ▶ To screw on or unscrew valve body or actuator, use an open-end wrench, never a pipe wrench, and observe tightening torques.

Risk of injury from unintentional activation of the system and an uncontrolled restart!

- ▶ Secure system from unintentional activation.
- ▶ Following maintenance, ensure a controlled restart.



WARNING!

For control function I – Danger if pilot pressure fails!

For control function I control and resetting occur pneumatically.

If the pressure fails, no defined position is reached.

- ▶ To ensure a controlled restart, first pressurize the device with pilot pressure, then switch on the medium.

Risk of injury from moving parts in the device!

- ▶ Do not reach into openings.

10.2 Maintenance work

Actuator:

The actuator of the angle-seat control valve is maintenance-free provided it is used according to these operating instructions.

Wearing parts of the angle-seat control valve:

Parts which are subject to natural wear:

- Valve seat
- Control cone
- Seals

→ If leaks occur, replace the particular wearing part with an appropriate spare part.

(For spare-part sets see chapter entitled "[12 Replacement parts](#)").



The replacing of the wearing parts is described in chapter “10.3 Replacing the wearing parts”.

Visual inspection:

Perform regular visual inspections according to the application conditions:

- Check media connections for leaks.
- Check release bore on the tube for leaks.

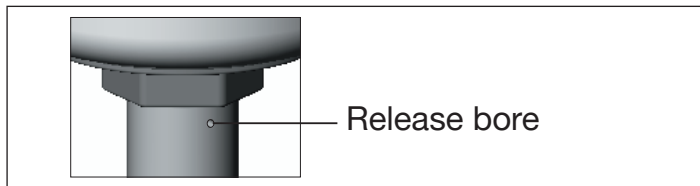

Fig. 24: Release bore

10.2.1 Cleaning

Commercially available cleaning agents can be used to clean the outside.

NOTE!

Avoid causing damage with cleaning agents.

- ▶ Before cleaning, check that the cleaning agents are compatible with the body materials and seals.

10.3 Replacing the wearing parts

10.3.1 Replacing the control cone set

The control cone set consists of

- Control cone
- Graphite seal
- Dowel pin
- Lubricant

Before the control cone set can be replaced, the actuator must be removed from the valve body.



DANGER!

Risk of injury from discharge of medium and pressure!

It is dangerous to remove a device which is under pressure due to the sudden release of pressure or discharge of medium.

- ▶ Before removing a device, switch off the pressure and vent the lines.



WARNING!

Risk of injury if the wrong tools are used!

It is dangerous to use unsuitable tools for installation work as the device may be damaged.

- ▶ To remove the actuator from the valve body, use an open-end wrench, never a pipe wrench.

Removing the actuator from the valve body

- Clamp the valve body in a holding device (applies only to valves which have not yet been installed).

NOTE!

Damage to the seat seal or the seat contour!

- ▶ When removing the actuator, ensure that the valve is in open position.

→ Control function A:

Without unit control: pressurize the pilot air port 1 with compressed air (5 bar): valve opens.

With unit control: open the valve according to the operating instructions for the control unit.

- Using a suitable open-end wrench, place the wrench flat on the pipe.
- Unscrew the actuator from the valve body.

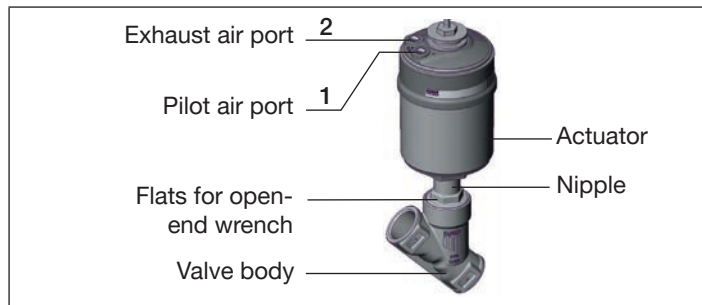

Fig. 25: Valve

Replace the control cone set

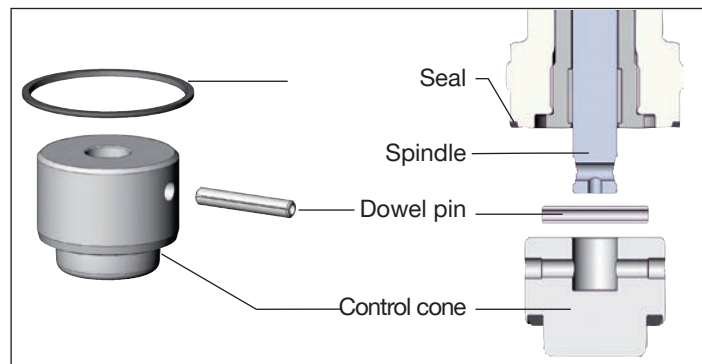

Fig. 26: Replacing the control cone set

NOTE!

Important information for the problem-free and safe functioning of the device!

The sealing face of the control cone must not be damaged.

Procedure:

- Knock out dowel pin with a suitable pin punch.
Pin punch \varnothing 4 mm, for spindle diameter 10 mm
Pin punch \varnothing 5 mm, for spindle diameter 14 mm
- Remove control cone.
- Attach new control cone to the spindle.
- Align bores of the control cone and spindle.

Type 2300

Maintenance, cleaning

- Support control cone on the cylindrical part with the aid of a prism or something similar.
- Put on dowel pin and carefully knock in with a hammer.
- Position the dowel pin in the centre of the spindle axis.

Install the actuator (with control unit) on the valve body

- Check the seal and if required, replace it.



WARNING!

Danger if incorrect lubricants used!

Unsuitable lubricant may contaminate the medium. In oxygen applications there is a risk of an explosion!

- ▶ In specific applications, e.g. oxygen or analysis applications, use appropriately authorised lubricants only.

- Grease nipple thread before re-installing the actuator (e.g. with Klüber paste UH1 96-402 from Klüber).

NOTE!

Damage to the seat seal or the seat contour!

- ▶ When installing the actuator, ensure that the valve is in open position.

→ Control function A:

Without unit control: pressurize the pilot air port 1 with compressed air (5 bar): valve opens.

With unit control: open the valve according to the operating instructions for the control unit.

- Screw actuator into the valve body.
Observe tightening torque (see "[Tab. 17](#)").

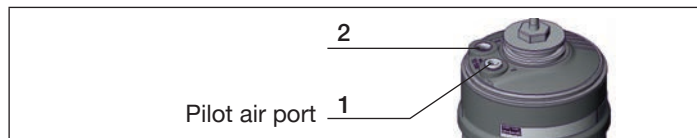

Fig. 27: Connections

Tightening torques of valve body / nipples

DN	Tightening torques [Nm]
15	45 ±3
20	50 ±3
25	60 ±3
32	65 ±3
40	
50	70 ±3
65	100 ±3

Tab. 17: Tightening torques of valve body / nipples





If the position of the pilot air ports for installation of the hoses is unfavorable, these can be aligned steplessly by rotating the actuator through 360°.

The procedure is described in the chapter entitled "[8.3.4 Rotating the actuator](#)".

10.3.2 Replacing the packing gland

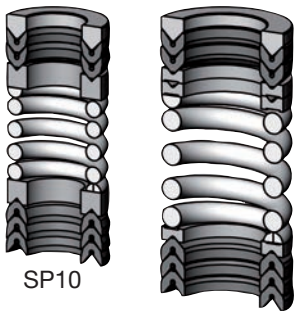
The seal set for the packing gland contains

<p>SP10 / SP14</p> <ul style="list-style-type: none"> • 1 support ring • 5 chevron seals • 2 or 3 pressure rings¹²⁾ • 1 pressure spring • 1 seal • Lubricant 	 <p style="text-align: center;">SP10 SP14</p>
<p>SP22</p> <ul style="list-style-type: none"> • 1 support ring • 7 chevron seals • 2 pressure rings • 1 pressure spring • 1 spacer • 1 seal • Lubricant 	

Tab. 18: Seal set for packing gland

¹²⁾ depending on the spindle diameter (10 or 14 mm)



DANGER!

Risk of injury from discharge of medium and pressure!

It is dangerous to remove a device which is under pressure due to the sudden release of pressure or discharge of medium.

- ▶ Before removing a device, switch off the pressure and vent the lines.



WARNING!

Risk of injury if the wrong tools are used!

It is dangerous to use unsuitable tools for installation work as the device may be damaged.

- ▶ To remove the actuator from the valve body, use an open-end wrench, never a pipe wrench.
- ▶ To replace the packing gland, use a special installation wrench, modified socket wrench or a socket wrench.
- ▶ Observe tightening torques.

Before the packing gland can be replaced, the actuator must be removed from the valve body and the control cone removed.

Type 2300

Maintenance, cleaning

Removing the actuator from the valve body

- Clamp the valve body in a holding device (applies only to valves which have not yet been installed).

NOTE!

Damage to the seat seal or the seat contour!

- ▶ When removing the actuator, ensure that the valve is in open position.

→ Control function A:

Without unit control: pressurize the pilot air port 1 with compressed air (5 bar): valve opens.

With unit control: open the valve according to the operating instructions for the control unit.

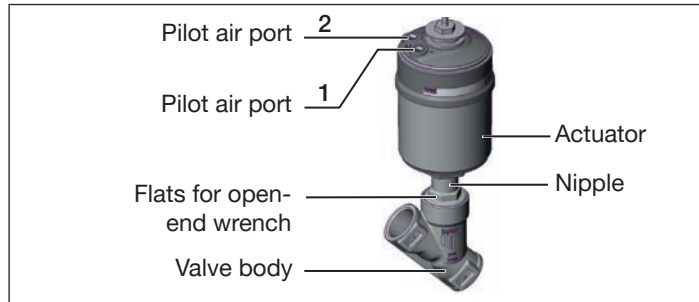

Fig. 28: Valve

- Using a suitable open-end wrench, place the wrench flat on the pipe.
- Unscrew the actuator from the valve body.

Removing the control cone set

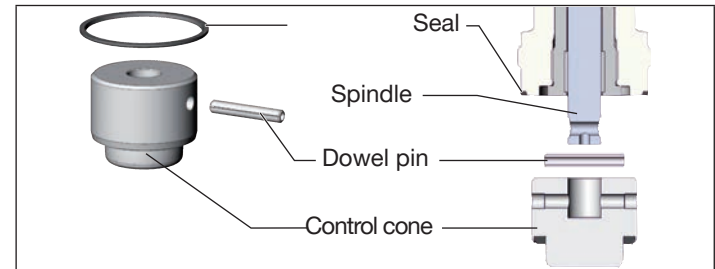

Fig. 29: Replacing the control cone set

NOTE!

Important information for the problem-free and safe functioning of the device!

The sealing face of the control cone must not be damaged.

Procedure:

- Knock out the dowel pin with a suitable pin punch.
Pin punch \varnothing 4 mm, for spindle diameter 10 mm.
Pin punch \varnothing 5 mm, for spindle diameter 14 mm.
- Remove control cone.

Replacing packing gland

PEEK spindle guide (series production status up to April 2012):

→ Unscrew the spindle guide with the aid of the installation wrench¹³⁾ and an open-end wrench.

VA spindle guide (Series production status since April 2012):

→ Unscrew spindle guide using a modified socket wrench¹³⁾.

SP22:

→ Unscrew the VA spindle guide with the aid of an open-end wrench.

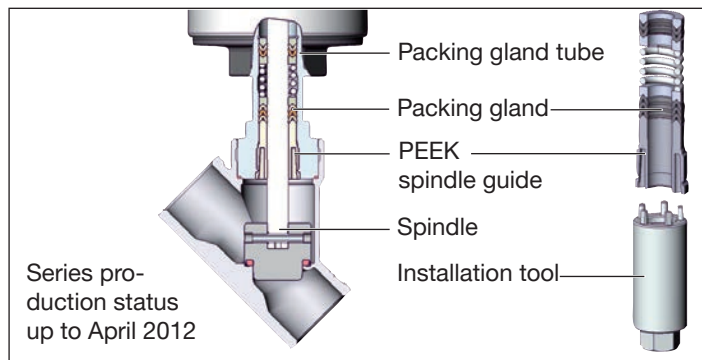

Fig. 30: Replacing packing gland (PEEK spindle guide)

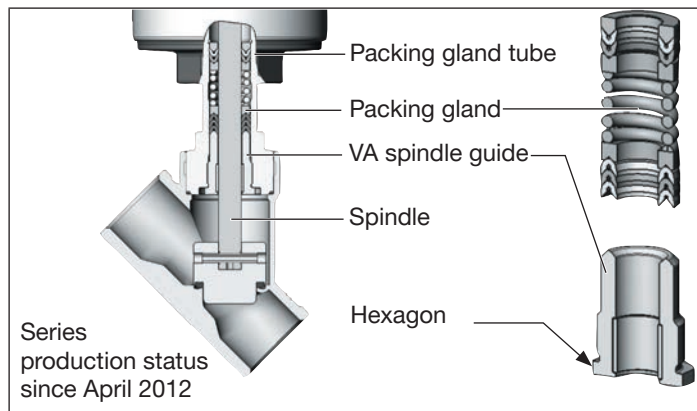

Fig. 31: Replacing packing gland (VA spindle guide)

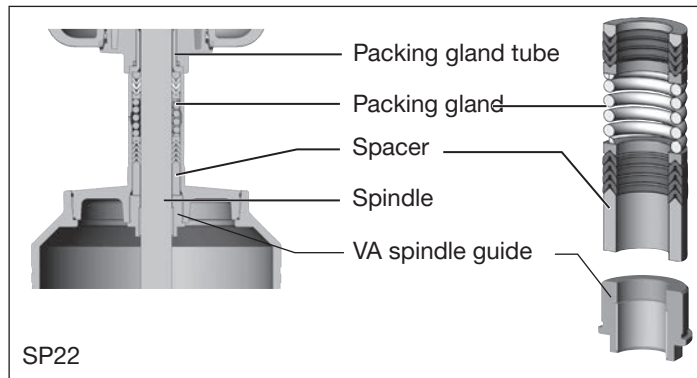

Fig. 32: Replacing packing gland SP22

13) The installation wrench or modified socket wrench is available from your Bürkert sales office.



WARNING!

Risk of injury from parts jumping out!

When the spindle opening is exposed, the individual parts of the packing gland are pressed out at an undefined speed when the pilot air ports is pressurized.

- ▶ Before pressurizing with control air, safeguard the ambient area of the discharge opening (e.g. place spindle on a firm base).

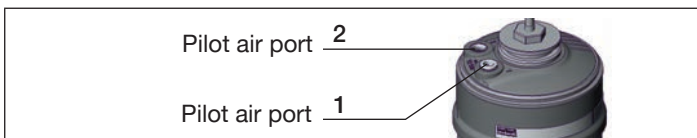

Fig. 33: Connections

- Press out packing gland:
Control function A and I Pressurize pilot air port 1 with 6 – 8 bar.
Control function B Pressurize pilot air port 2 with 6 – 8 bar.
- Grease the individual parts of the new packing gland with the applied lubricant.
- Connect the individual parts to the spindle in the specified direction and sequence (as illustrated in “Fig. 34” or “Fig. 35”).
- Push packing gland into the packing gland tube.



If the valve features a PEEK spindle guide (series production status up to April 2012), we recommend replacing it with a VA spindle guide (see “Tab. 25: VA spindle guide for packing gland”, page 42)

- Grease thread of the spindle guide (Klüber paste UH1 96-402).
- Screw spindle guide back in using the installation tool. Observe torque (see “Tab. 19: Tightening torques of spindle”!)

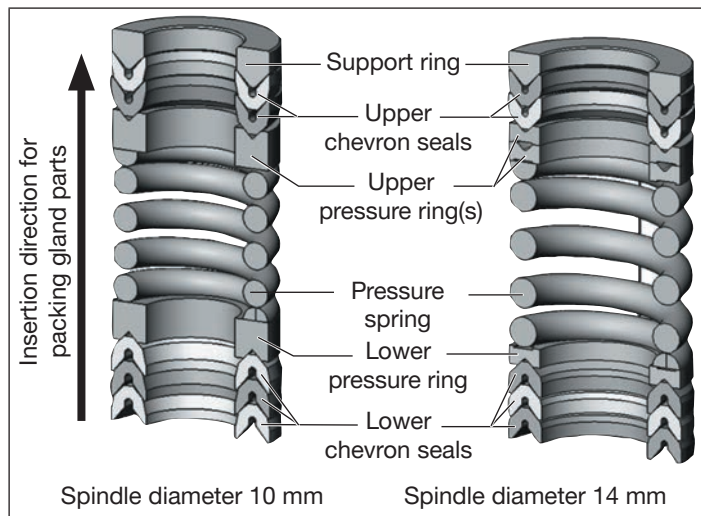

Fig. 34: Seal set for packing gland SP10 / SP14

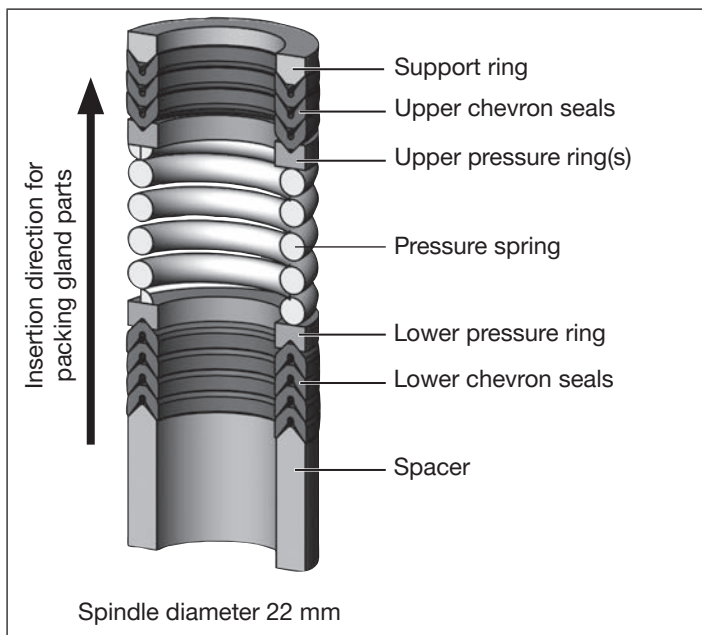

Fig. 35: Seal set for packing gland SP22

Tightening torques of spindle			
Spindle diameter	Orifice body	Material of spindle guide	Tightening torque [Nm]
10 mm		PEEK	6
	15	1.4401 / 1.4404 / 316L	15
	20 – 25		25
	32		50
14 mm		PEEK	15
	25	1.4401 / 1.4404 / 316L	25
	32 – 50		60
22 mm	65	1.4401 / 1.4404	60

Tab. 19: Tightening torques of spindle

Installing the control cone

- Attach new control cone to the spindle.
- Align bores of the control cone and spindle.
- Support control cone on the cylindrical part with the aid of a prism or something similar.
- Put on dowel pin and carefully knock in with a hammer.
- Position the dowel pin in the centre of the spindle axis.

Type 2300

Maintenance, cleaning

Install the actuator (with control unit) on the valve body

→ Check the seal and if required, replace it.



WARNING!

Danger if incorrect lubricants used!

Unsuitable lubricant may contaminate the medium. In oxygen applications there is a risk of an explosion!

▶ In specific applications, e.g. oxygen or analysis applications, use appropriately authorised lubricants only.

→ Grease nipple thread before re-installing the actuator (e.g. with Klüber paste UH1 96-402 from Klüber).

NOTE!

Damage to the seat seal or the seat contour!

▶ When installing the actuator, ensure that the valve is in open position.

→ **Control function A:**

Without unit control: pressurize the pilot air port 1 with compressed air (5 bar): valve opens.

With unit control: open the valve according to the operating instructions for the control unit.

→ Screw actuator into the valve body.

Observe tightening torque (see "[Tab. 20](#)").

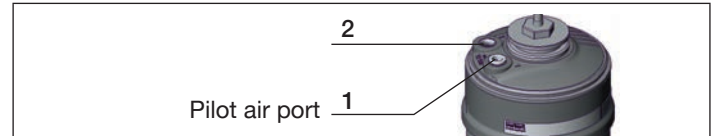

Fig. 36: Connections

Tightening torques of valve body / nipples

DN	Tightening torques [Nm]
15	45 ±3
20	50 ±3
25	60 ±3
32	65 ±3
40	
50	70 ±3
65	100 ±3

Tab. 20: Tightening torques of valve body / nipples



If the position of the pilot air ports for installation of the hoses is unfavorable, these can be aligned steplessly by rotating the actuator through 360°.

The procedure is described in the chapter entitled "[8.3.4 Rotating the actuator](#)".

11 MALFUNCTIONS

Malfunction	Remedial action
Actuator does not switch.	Pilot air port interchanged ¹⁴⁾ CFA: Connecting pilot air port 1 CFB: Connecting pilot air port 1 CFI Pilot air port 1: Open Pilot air port 2: Close
	Pilot pressure too low See pressure specifications on the type label.
	Medium pressure too high See pressure specifications on the type label.
	Flow direction reversed See direction arrow on the type label.

Tab. 21: Malfunctions - 1

Malfunction	Remedial action
Valve is not sealed.	Dirt between seal and valve seat → Installing dirt trap
	Seat seal worn → Installing a new control cone
	Flow direction reversed See direction arrow on the body.
	Medium pressure too high See pressure specifications on the type label.
Valve is leaking on the release bore.	Pilot pressure too low See pressure specifications on the type label.
	Packing gland worn → Replacing packing gland.

Tab. 22: Malfunctions - 2

¹⁴⁾ See [“Fig. 23: Pneumatic connection”](#) .

12 REPLACEMENT PARTS



WARNING!

Risk of injury when opening the actuator!

The actuator contains a tensioned spring. If the actuator is opened, there is a risk of injury from the spring jumping out!

- ▶ The actuator must not be opened.



CAUTION!

Risk of injury and/or damage by the use of incorrect parts!

Incorrect accessories and unsuitable replacement parts may cause injuries and damage the device and the surrounding area.

- ▶ Use only original accessories and original replacement parts from Bürkert.

12.1 Replacement part sets

Replacement part sets for the angle-seat control valve Type 2300:

- Control cone set consisting of control cone, dowel pin, seal and lubricant.
- Sealing set for packing gland consisting of the individual parts of the packing gland, seal and lubricant (the (modified) socket wrench is not included in the sealing set).
- Spindle guide for packing gland consisting of VA spindle guide, seal and lubricant.

Control cone set			
DN	Actuator size [mm]	Order no.	
		PTFE / Steel	Steel / Steel
15	∅ 50, ∅ 70	170 315	170 322
20	∅ 50, ∅ 70	170 316	170 323
25	∅ 50, ∅ 70, ∅ 90	170 318	170 324
32	∅ 70	170 319	170 325
	∅ 90, ∅ 130	226 941	226 925
40	∅ 90, ∅ 130	226 945	225 423
50	∅ 90, ∅ 130	226 948	225 426
65	∅ 130	226 950	225 427

Tab. 23: Control cone set

Sealing set for packing gland			
Spindle ∅ [mm]	DN	Actuator size [mm]	Order no.
10	15 – 32	∅ 50	216 436
		∅ 70	
14	25 – 50	∅ 90	216 438
		∅ 130	
22	65	∅ 130	252 545

Tab. 24: Sealing set for packing gland

VA spindle guide for packing gland			
Spindle \varnothing	DN	Actuator size	Order no.
10	15	$\varnothing 50, \varnothing 70$	246 577
	20 / 25	$\varnothing 50, \varnothing 70$	246 578
	32	$\varnothing 70$	246 582
14	25	$\varnothing 90$	246 579
	32	$\varnothing 90, \varnothing 130$	246 583
	40	$\varnothing 90, \varnothing 130$	246 593
	50	$\varnothing 90, \varnothing 130$	246 594
22	65	$\varnothing 130$	252 544

Tab. 25: VA spindle guide for packing gland

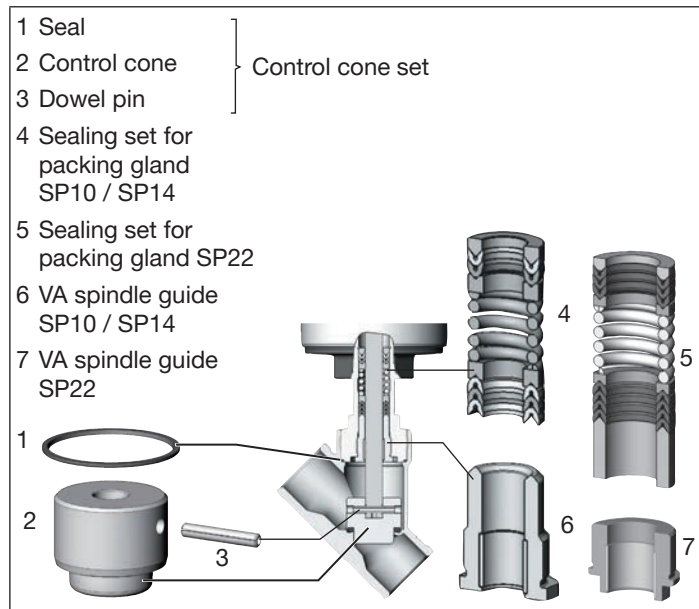

Fig. 37: Replacement parts

12.2 Installation tools

Only for PEEK spindle guide: Installation wrench for packing gland (Series-production status until April 2012)	
Installation wrench	Order no.
Spindle diameter 10 mm	665 700
Spindle diameter 14 mm	665 701

Tab. 26: Installation wrench for PEEK spindle guide

Modified socket wrench for packing gland (Series production status since April 2012)				
	Socket wrench	Orifice DN	AF	Order no.
	Spindle Ø 10 mm	15	19	683 220
	Spindle Ø 10 mm	20 – 32	21	683 222
	Spindle Ø 14 mm	25 – 50	21	683 223

Tab. 27: Modified socket wrench

Only for actuator without hexagon: Special wrench for rotating the actuator (Series-production status until end of 2011)	
Order no.	665 702

Tab. 28: Special wrench for actuator without hexagon



If you have any queries, please contact your Bürkert sales office.

13 PACKAGING, TRANSPORT, STORAGE

NOTE!

Transport damages!

Inadequately protected equipment may be damaged during transport.

- During transportation protect the device against wet and dirt in shock-resistant packaging.
- Avoid exceeding or dropping below the permitted storage temperature.

Incorrect storage may damage the device.

- Store the device in a dry and dust-free location!
- Storage temperature -20...+65 °C.

Damage to the environment caused by device components contaminated with media.

- ▶ Dispose of the device and packaging in an environmentally friendly manner.
- ▶ Observe applicable regulations on disposal and the environment.



Note:

Observe national waste disposal regulations.

www.burkert.com