

## Quick Reference Guide

# WAV252 Heated Wind Vane

## Installation and Maintenance

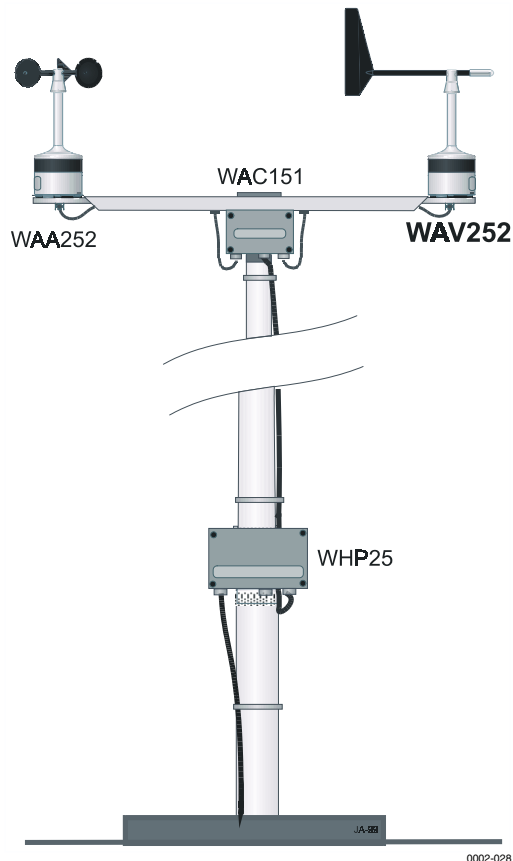

## INSTALLATION

### Initial Check

Prior to the installation check that the WAV252 is not damaged during transportation. Check also that the shaft rotates smoothly without any detectable noise. It is recommended to mount the sensor body when the vane assembly is removed. Be careful not to cause damage to the shaft of the sensor body or to the connector pins.

### Mechanical

The Heated Wind Vane WAV252 is preferably installed into the WAC151 sensor cross arm. On bottom of the WAV252 there is a special button-shaped temperature sensor (diameter 22 mm), elastically attached to the bottom plate. This is for sensing the ambient temperature and should therefore be set in good thermal contact with the mounting support.

**NOTE** The three mounting screws properly tightened will force the temperature sensor button firmly enough against the support.

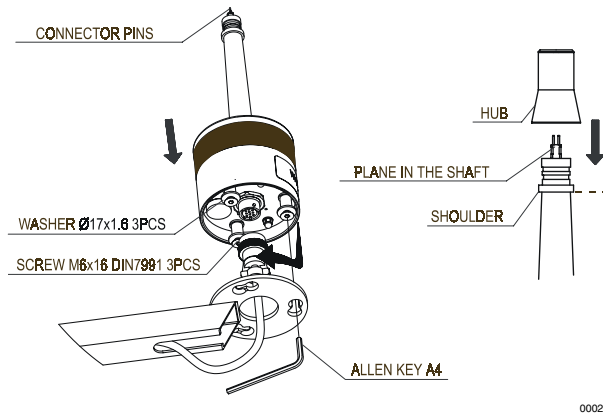

Figure 1. Mounting of the Wind Sensor and the Hub

When installed to the WAC151 cross arm, the WAV252 is mounted at the northern end, the southern end is reserved for the WAA252 Heated Anemometer.

1. First pre-assemble the three mounting screws, with plastic pre-washers, to the anemometer's mounting legs.
2. Fit the 10-pin cable plug through the mounting flange and connect it to the sensor.

3. Mount the sensor to the flange by twisting, and tighten the screws.
4. Finally, mount the cup assembly. Align the planes in the shaft and inside the hub. The bottom edges of the hub and the shoulder should reach approximately the same level (see Figure 1). Tighten the set screw.

### WAC151 Wiring

The wiring diagram for the WA252 system to the WAC151 Sensor Crossarm is presented in the Figure 2. The power input wire connections are highlighted, since they differ from those for regular wind sensors.

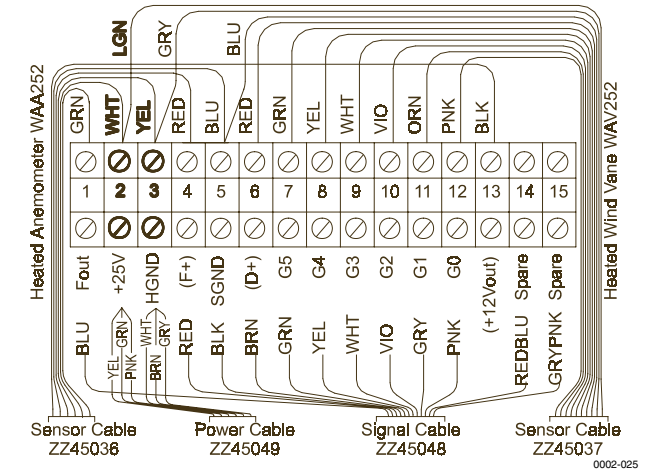

Figure 2. WAC151 Standard Wiring for WAA252 and WAV252

When using standard power and signal cables ZZ45049 and ZZ45048 the connections are following:

1. For power supply, connect the YEL, GRN, and PNK colored wires to the screw terminal #2 and the WHT, BRN, and GRY colored wires to the terminal #3.
2. For signal output connect wires GRN, YEL, WHT, VIO, GRY, and PNK to terminals #7 ... #12. For signal grounding, connect BLK to the terminal #5.
3. For the optional sensor power input connect BRN to the terminal #6.

As a power source use the Vaisala WHP25 Mains Power Supply, which has a mast mountable, all-weather enclosure. For a typical installation see the figure on the front page.

## MAINTENANCE AND REPAIR

Ball bearings must be checked once a year visually and by rotating the sensor shaft. To do this, remove first the vane assembly as instructed below (A1). The shaft should spin smoothly and should not create any detectable noise.

Replacement of the bearings should be done only by a trained technician. Steps A1 to A15 are for disassembling and steps B1 to B10 are for reassembling. The numbers in parenthesis refer to Figure 3.

- A1.** Loosen the set screw (use allen key) and carefully remove the vane assembly.

**CAUTION** Be careful with the connector pins, do not bend them.

- A2.** Loosen the hex nut of the green MIL-connector at the bottom of the sensor body (use 22 mm tool).  
**A3.** Loosen the three capnuts (1) at the bottom of the sensor body (use 7 mm tool).  
**A4.** Remove the body cover and the O-rings (2).  
**A5.** Release the connector (3) of two white wires from the power supply board (4).  
**A6.** Loosen the three nuts (5) at the bottom of the power supply board (4) and remove it (use 7 mm tool).  
**A7.** Loosen the shaft heating foil (6) (use pliers).  
**A8.** Loosen the set screw of the rotating transformer assembly (7) (use allen key).  
**A9.** Loosen the spacer screws (8) (use 6 mm tool).  
**A10.** Remove the sensor board (9) together with the rotating transformer assembly (7).

**CAUTION** Handle the rotating transformer carefully, do not drop or hit.

- A11.** Remove the retaining ring (10) (use narrow-pointed pliers) and the bushing from the shaft tunnel.  
**A12.** Remove the upper bearing (12) after pulling out the shaft.

**CAUTION** Handle the shaft carefully, do not drop or hit.

- A13.** Remove the retaining ring (13) at the shaft.  
**A14.** Remove the lower bearing (14).

For reassembling the sensor:

- B1.** Install the bearings in reverse order.

**NOTE** Be careful when assembling the bearings.

- B2.** The rotating transformer assembly (7) is reinstalled together with the sensor board (9). Its (7) set screw is not fastened until in step **B7**, when the power supply board has been reinstalled and the gap adjusted.  
**B3.** In assembling, push the transformer (7) as far up as possible towards the shaft tunnel.  
**B4.** Reassemble the spacer screws (8), the power supply board (4) and tighten the nuts (5).

**NOTE** Make sure the four pin connector (15) installs properly.

- B5.** For adjusting the gap, place a 0.4 mm feeler gauge between ferrite coils (parts 4 and 7) (preferably use 30 mm wide feeler gauge).  
**B6.** Place a screwdriver tip into the slot between the top end of rotating transformer assembly (7) and the shaft tunnel, and pry until the air gap between ferrite coils is 0.4 mm (0.016") (use feeler gauge for measuring).

**CAUTION** The ferrite coils are breakable, do not try to adjust the gap by prising them.

- B7.** When the gap is right, fasten the set screw of the rotating transformer assembly (7).

**CAUTION** Make sure the rotating transformer assembly rotates freely without touching the lower part at any rotary position of the shaft.

- B8.** Reconnect the shaft heating foil (6) and the connector of two white wires (3).  
**B9.** Reassemble the body cover (2) with new O-rings.  
**B10.** Tighten the three capnuts (1) and the connector nut.  
**B11.** Install the vane as instructed in mechanical section.

Spare parts:	Order number:
Vane assembly for WAV252	WA35336
Set of bearings and gasket	16644WA

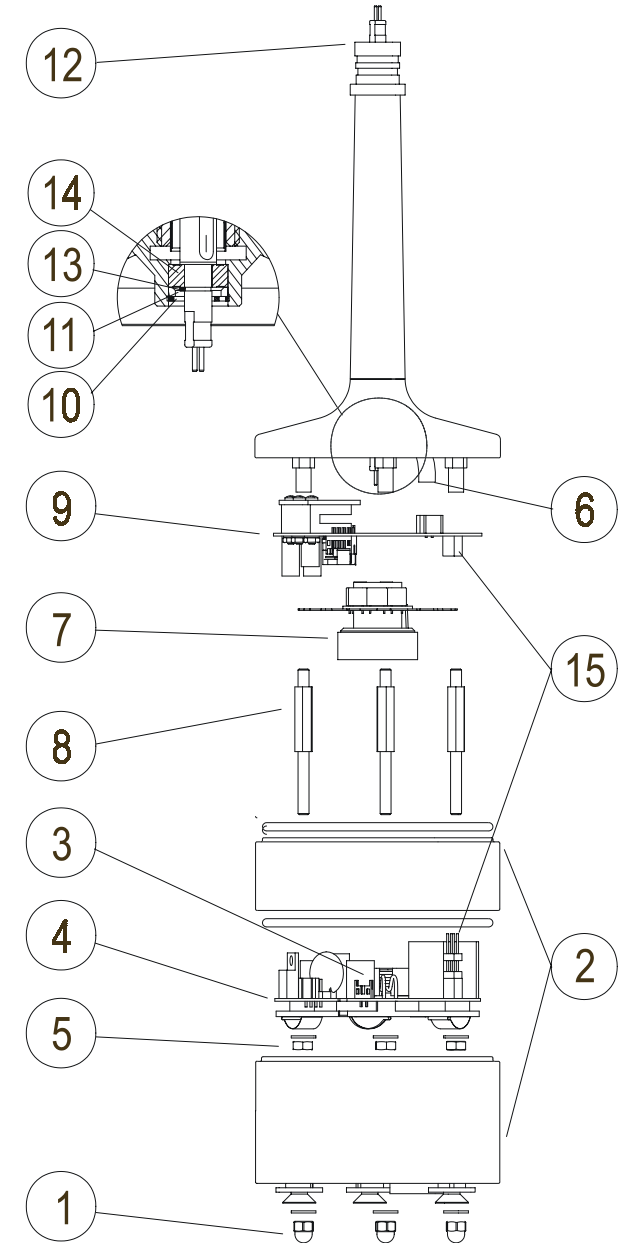

Figure 3. WAV252 Assembly