



# Remote Display Panel RDP100

## for Cleanrooms



### Features

- Displays one or two selected environmental parameters
- Recessed, slim design makes the device easy to clean – ideal for cleanrooms
- Front panel materials are resistant to most commonly used cleaning agents
- Easy to install and configure without special tools
- Digital data communication from sensor – no calibration needed for the display
- Supported Vaisala instruments: HMDW110 series transmitters, HMP60/63/110/113, DMT132, DMT143, DPT146, DMT152, and MMT162

Vaisala Remote Display Panel RDP100 is a digital display that shows one or two selected environmental measurement parameters.

The display can be used in combination with several Vaisala humidity, temperature, dew-point, pressure, and moisture-in-oil instruments. RDP100 can be easily installed in selected locations, allowing easy review of measurement data wherever it is most needed. The thin front panel and chemically-resistant materials make it ideal for use in demanding environments such as cleanrooms.

### Measurement Data Always Visible

Measuring instruments are commonly installed in locations where data is difficult to read, such as ventilation ducts or confined spaces. Instruments equipped with an integrated display are difficult to use and not ideal for data viewing and collection. RDP100 is connected to the measuring instrument with a cable. The display can then be installed in the most convenient location, such as on a wall – making data easier to read.

### Thin Front Panel is Easy to Clean

Cleanroom equipment and instruments need to generate minimal contamination and be easy to clean. RDP100's recessed design and very thin front panel (8 mm) minimize the surface area and amount of cleaning needed. The instrument's smooth surface does not have any holes or grooves, making it easier to keep clean and free of contamination. In addition, the front panel is made of stainless steel and glass, both of which have excellent resistance to the most commonly used detergents and disinfectants, as well as hydrogen peroxide decontamination.

### Fast and Easy Installation and Setup

Remote displays can be difficult to install in the desired location due to complex wiring or wall structures. The display may also need a power supply, meaning additional wiring and changes in, for example, cleanroom wall structures. When RDP100 is used together with a

Vaisala HMDW110 series transmitter, the power is provided by the transmitter to the display with a single cable. This allows for quick and easy installation in various locations, as additional wiring to a power supply is not needed.

A maximum of two measurement parameters can be displayed, depending on the sensors used. Selecting parameters is fast and easy using a DIP switch, with no special tools or PC needed for setup.

### Calibration Free

The measurement data is digitally transmitted by the sensor to the display, meaning the display itself never needs removing for calibration. This is especially advantageous in a cleanroom, where any changes in wall mounting may cause a risk of contamination. In addition, since the signal of the transmitter is generic, measurement instruments are fully interchangeable and can be rotated for calibration, allowing gap-free measurement during calibration periods.

# Technical Data

## Operating Environment

Operating temperature	+10 ... +40 °C
Storage temperature	-40 ... +60 °C
Operating humidity	0 ... 95 %RH
EMC compliance	EN61326-1, Industrial Environment

## Inputs and Outputs

Supply voltage	External power supply 12 ... 28 VDC or supplied by HMD110/112, HMW110/112, HMS110/112
----------------	---

Current consumption	1 mA typical
Data input	RS-485, Vaisala proprietary protocol
Supported transmitters	HMD110/112, HMW110/112, HMS110/112, HMP60/63, HMP110/113, DMT132/143/152, DPT145/146, MMT162

Output voltage	Can supply regulated power for HMP60/63/110/112 from external power supply Power for DMT132/143/152, DPT145/146, and MMT162 can pass through the RDP100
----------------	--

### Connector

Type	Screw terminals
Max wire size	1.5 mm <sup>2</sup> (AWG 16)

## Mechanical Specifications

Weight	125 g
--------	-------

### Materials

Cover	Stainless steel AISI304
Display window	Glass
Display window adhesive	Acrylic foam AFTC5046
Mounting box	Polypropylene

### Display

Type	LCD monochrome (128x64)
Displayed measurements	One or two simultaneously
Selection of quantities and units	Via DIP switches

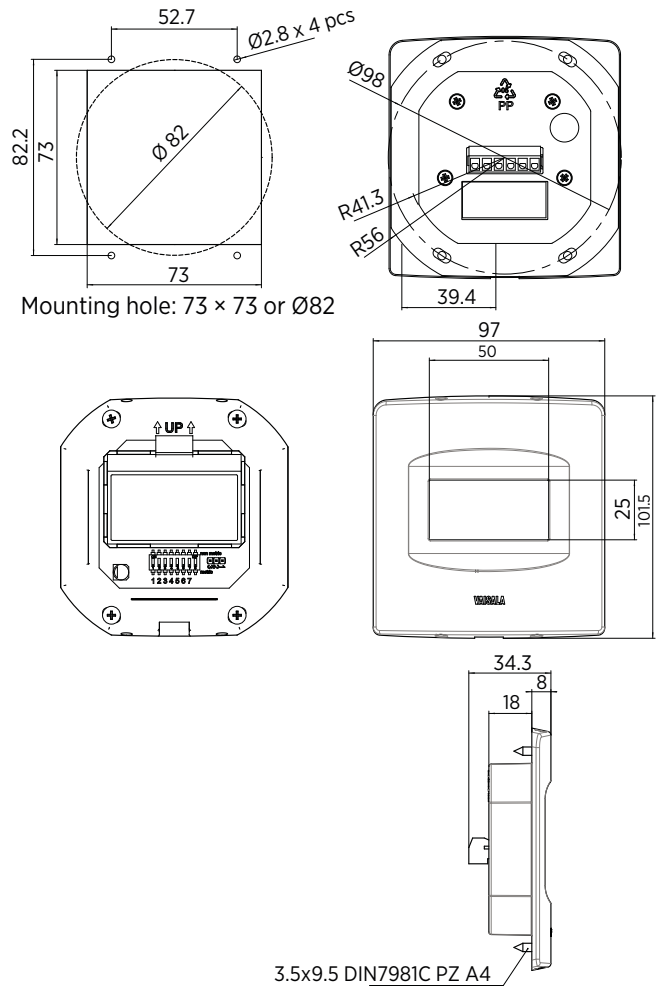

Dimensions in mm



**VAISALA**

www.vaisala.com

Published by Vaisala | B211361EN-B © Vaisala 2017

All rights reserved. Any logos and/or product names are trademarks of Vaisala or its individual partners. Any reproduction, transfer, distribution or storage of information contained in this document is strictly prohibited. All specifications – technical included – are subject to change without notice.