

Series SPL 35-150

12 BAR (170 PSI)

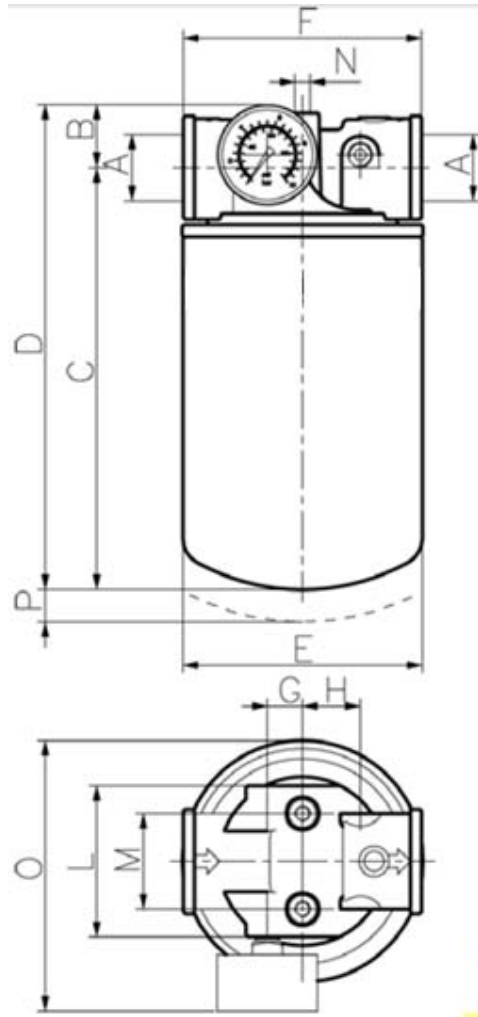

Dimensions:

type	A	B	C	D	E	F	G	H	L	M	N	O	P
SPL 35	3/4"	22 [0.87]	168 [6.61]	190 [7.48]	96 [3.78]	95 [3.74]	14 [0.55]	23 [0.91]	60 [2.36]	38 [1.5]	M6	63 [2.48]	20 [0.79]
SPL 55	3/4"	22 [0.87]	233 [9.17]	255 [10.04]	96 [3.78]	95 [3.74]	14 [0.55]	23 [0.91]	60 [2.36]	38 [1.5]	M6	63 [2.48]	20 [0.79]
SPL 75	1 1/4"	30 [1.18]	211 [8.31]	241 [9.49]	127 [5.00]	133 [5.24]	16 [0.63]	35 [1.38]	94 [3.70]	50 [1.97]	M8	80 [3.15]	25 [0.98]
SPL 150	1 1/4"	31 [1.22]	344 [13.54]	375 [14.76]	138 [5.43]	140 [5.51]	16 [0.63]	35 [1.38]	105 [4.13]	68 [2.68]	M8	80 [3.15]	40 [1.57]

Dimensions: mm [inches]

Designs and performance values are subject to change.

Spin-On Filter

Series SPL 35-150

12 BAR (170 PSI)

Description:

Eaton's spin-on filters are designed to provide one of the highest cleanliness levels for hydraulic systems, featuring cartridges that are engineered to fit into many leading filter systems on the market.

Series SPL filters are available with the following features:

- Compatible with a variety of mediums such as oils, fuels, emulsions, glycol water and synthetic fluids
- Cartridge pressure is 12 bar (170 psi)
- Cartridge replacement does not require any tooling or equipment to optimize maintenance efficiency
- Other configurations are available upon request

Eaton's spin-on filters are manufactured and tested according to ISO 2941, ISO 3723 and ISO 2942.

1. Type index:

1.1. Complete filter: (ordering example)

SPL.	35.	10VG.	G.	4.	R.	-
1	2	3	4	5	6	7

1 | series:

SPL = low pressure spin-on filter

2 | Nominal size: 35, 55, 75, 150

3 | filter-material:

25VG, 10VG, 6VG, 3VG microglass

4 | process connection:

G = BSPP thread connection

NPT = NPT thread connection

5 | process connection size:

4 = 3/4" (SPL 35/55)

6 = 1 1/4" (SPL 75/150)

6 | bypass valve:

- = without

R = bypass valve filter Δp 1.75 BAR (25 PSI)

7 | clogging indicator:

- = without

O3 = visual return

1.2. Filter element: (ordering example)

01SL. 35. 10VG

1	2	3
---	---	---

1 | series

SL = spin-on cartridge for low pressure filter

2 | nominal size: 35, 55, 75, 150

3 | filter-material:

25VG, 10VG, 6VG, 3VG microglass

Technical data:

operating temperature:	-25°C to +110°C (-13°F to +230°F)
operating medium	mineral oil, other media on request
max. operating pressure:	12 BAR (170 PSI)
opening pressure by-pass valve:	Δp 1.75 BAR (25 PSI)
pressure gauge:	0-10 BAR (0-150 PSI)
gasket:	Nitrile (NBR)

Classified under the Pressure Equipment Directive 2014/68/EC for mineral oil (fluid group 2), Article 4, Para. 3.
Classified under ATEX Directive 2014/34/EC according to specific application (see questionnaire sheet-no. 34279-4).

Pressure drop flow curves:

Curves are calculated in accordance with ISO 3968 and are valid for clean filtering elements.

ΔP changes along with the density in presence of an eddy flow, and along with the dynamic viscosity in presence of a laminar flux.

Curves are valid for mineral oils with density of 0,86 kg/dm³ and a kinematic viscosity of 30 mm²/sec (cSt) (139 SUS).

When choosing the filtering medium consider the pressure losses deriving from the flow rate:

Between 0,05-0,1 bar (0,73 – 1,45 psi) for suction line.

Up to 0,3-0,5 bar (4,35 – 7,25 psi) for filters fitted on return line.

(The total pressure drop of assembly is to be calculated by sum of housing Δp and the element Δp)

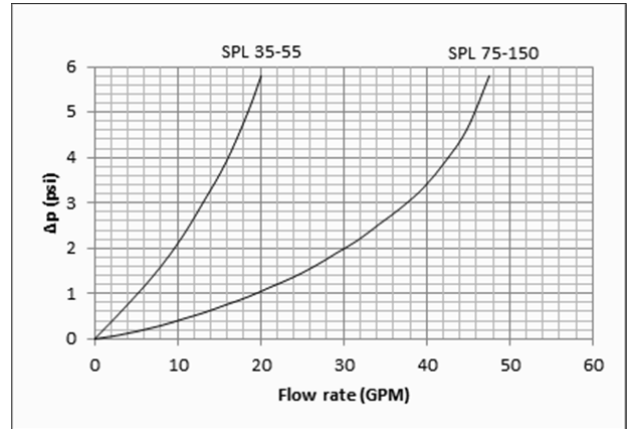
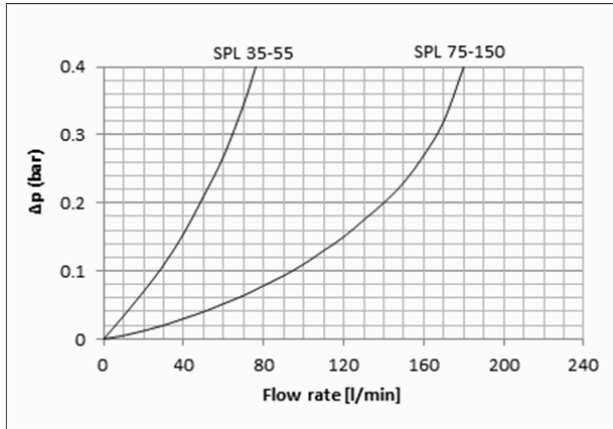

Clogging Indicator:

Dimensions: mm [inches]

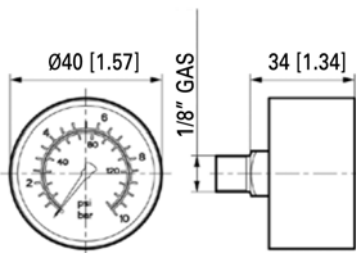

Type:	O3	(visual return)
Housing:	black plastic	
Measuring element:	copper spring	
Precision rate:	1,6	
Protection rate:	IP31	
Threaded:	Axial type	
Setting:	0-10 bar (0-150 psi)	

Symbols:

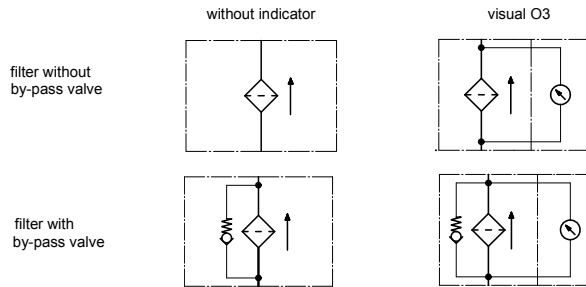

Test methods:

Filter elements are tested according to the following ISO standards:

ISO 2941	Verification of collapse/burst resistance
ISO 2942	Verification of fabrication integrity
ISO 2943	Verification of material compatibility with fluids
ISO 3723	Method for end load test
ISO 3724	Verification of flow fatigue characteristics
ISO 3968	Evaluation of pressure drop versus flow characteristics
ISO 16889	Multi-pass method for evaluating filtration performance

North America

44 Apple Street
Tinton Falls, NJ 07724
Toll Free: 800 656-3344
(North America only)
Tel: +1 732 212-4700

Europe/Africa/Middle East

Auf der Heide 2
53947 Nettersheim, Germany
Tel: +49 2486 809-0

Friedensstraße 41
68804 Altlußheim, Germany
Tel: +49 6205 2094-0

An den Nahewiesen 24
55450 Langenlonsheim, Germany
Tel: +49 6704 204-0

China

No. 3, Lane 280,
Linhong Road
Changning District, 200335
Shanghai, P.R. China
Tel: +86 21 5200-0099

Singapore

4 Loyang Lane #04-01/02
Singapore 508914
Tel: +65 6825-1668

Brazil

Av. Julia Gaioli, 474 – Bonsucesso
07251-500 – Guarulhos, Brazil
Tel: +55 11 2465-8822

For more information, please

email us at filtration@eaton.com

or visit www.eaton.com/filtration

© 2016 Eaton. All rights reserved. All trademarks and registered trademarks are the property of their respective owners. All information and recommendations appearing in this brochure concerning the use of products described herein are based on tests believed to be reliable. However, it is the user's responsibility to determine the suitability for his own use of such products. Since the actual use by others is beyond our control, no guarantee, expressed or implied, is made by Eaton as to the effects of such use or the results to be obtained. Eaton assumes no liability arising out of the use by others of such products. Nor is the information herein to be construed as absolutely complete, since additional information may be necessary or desirable when particular or exceptional conditions or circumstances exist or because of applicable laws or government regulations.