

Stability of the Vaisala CARBOCAP® Carbon Dioxide Probe GMP231

The Vaisala GMP231 is an infrared CO₂ probe designed especially for heat sterilizable incubators. It measures CO₂ in the range of 0 ... 20% and is durable to incubator heat sterilization up to 195 °C. This paper describes the stability of the Vaisala GMP231 in two conditions: heat sterilization cycles and typical incubator atmosphere. The results show very stable behavior in all the tested cases.

Introduction CO₂ Incubators

Many life science applications, such as growing and storing cell cultures, require the carbon dioxide (CO₂) concentration to be measured and controlled. The required CO₂ atmosphere, along with the temperature and humidity, is commonly generated with a special climate chamber called a CO₂ incubator. In a typical CO₂ incubator, the CO₂ concentration is 5 %, temperature is 37 °C, and humidity is above 90 %RH.

Incubators are regularly sterilized, for example before new samples are put inside. A typical sterilization interval is once a month but they can vary greatly depending on the application. A common sterilization method is heat sterilization (hot air sterilization) in which the incubator is heated to 160 ... 190 °C for 30 ... 120 minutes, depending on the applied standard. CO₂ is not measured during sterilization.

The two most common CO₂ measurement techniques used in incubators are infrared absorption (IR) measurement and thermal conductivity (TC) measurement. The infrared method is generally considered better in terms

of accuracy, reliability, and insensitivity to humidity and temperature changes; its main disadvantage has been the inability of its measuring components to tolerate high sterilization temperatures. It has therefore been necessary to remove the infrared CO₂ sensor for the duration of the sterilization cycle and clean the removed CO₂ sensor separately by some other method. This increases the risk of contamination in CO₂ incubator use.

The Vaisala CO₂ Probe

The Vaisala GMP231 is the first commercially available infrared CO₂ probe that can withstand heat sterilization up to 195 °C. Because it is not necessary to remove the probe from the CO₂ incubator, the probe is easily and reliably sterilized with the incubator. The measurement range of GMP231 is 0 ... 20 % CO₂ and it has compensations for pressure, temperature, humidity, and oxygen concentration. The probe includes an internal pressure sensor for the pressure compensation and a heater to avoid sensor head condensation. For the CO₂ measurement, the probe has a Vaisala CARBOCAP® sensor

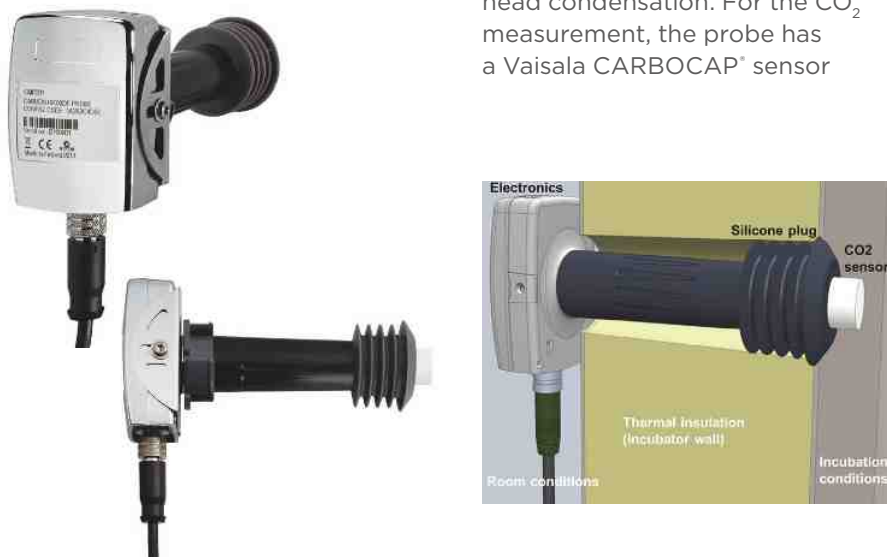

Figure 1. Typical installation of GMP231.

featuring single-beam, dual-wavelength infrared measurement using a silicon-based microglow infrared source and a Fabry-Pérot filter. The probe and its typical installation into an incubator are shown in [Figure 1](#).

Stability is one of the most critical sensor characteristics: a stable sensor provides reliable readings with a long calibration interval. This in turn makes the measured data more useful and decreases the maintenance costs. For each new sensor, stability needs to be properly investigated. This paper describes the stability of the Vaisala GMP231 probe in two conditions that are of particular importance for the incubator application: heat sterilization cycles (40 ... 195 °C) and typical incubator damp heat conditions (37 °C, 93 % RH).

Stability in Heat Sterilization Methods

The stability of the Vaisala GMP231 in heat sterilization was tested with six probes adjusted and calibrated before the test according to the normal manufacturing procedure. The probes were installed into a life science temperature chamber through the side walls (three probes per wall). The installation is shown in [Figure 2](#). In order to simulate the incubator heat sterilization, the test chamber was programmed to perform thermal cycling between 40 and 195 °C. Each cycle consisted of a rapid heating phase, a four-hour high-temperature phase at 195 °C, and a 3.3-hour cooling phase; the total duration of the cycle was about eight hours.

[Figure 3](#) shows the temperature inside the chamber measured with two Pt-100 sensors; one in the center of the chamber and the other near the CO₂ sensor and



Figure 2. GMP231 probes installed for the heat sterilization test. The PTFE filter covering the sensor head and the silicone installation plug can be seen in the inside view (left). The outside view (right) shows the wall feed-through.

minutes' data (300 points). The gas measurement setup and an example of the recorded data are presented in [Figure 4](#). Changes in the ambient pressure were compensated by using the internal pressure sensor of the probe. The pressure compensation is needed for accurate CO₂ concentration measurement because the density of gas, and thereby the number of CO₂ molecules in the absorption path of the sensor, depends on the ambient pressure. After the gas measurements, the probes were re-installed into the chamber to continue the high-temperature cycling.

During the high-temperature phase, the temperature at the center was about 195 °C and near the CO₂ sensor about 191 °C. The lower temperature was probably caused by thermal conduction via the probe installed in the feed-through. After each ~20 cycles, the probes were removed from the chamber and their reading was measured at four CO₂ concentrations (0, 5, 10, and 20 % CO₂) by using certified reference gas cylinders (AGA, relative uncertainty 0.5 %) at room temperature. At each concentration, the reading was calculated as an average of five

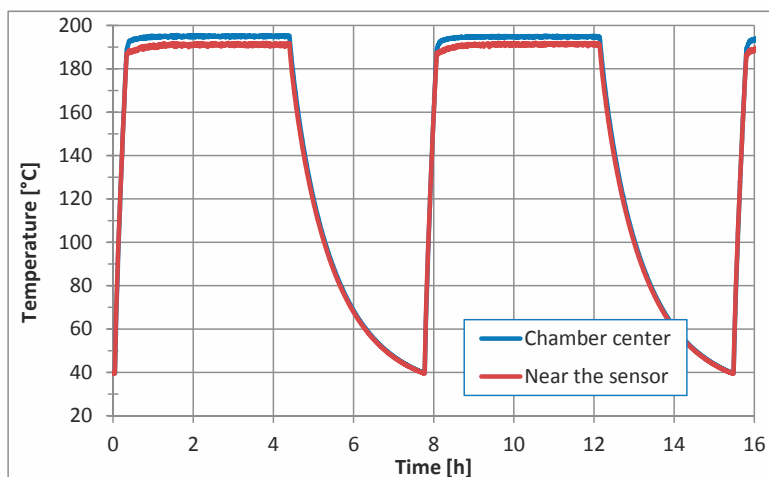

Figure 3. Temperature inside the chamber in the heat sterilization test (two cycles shown).

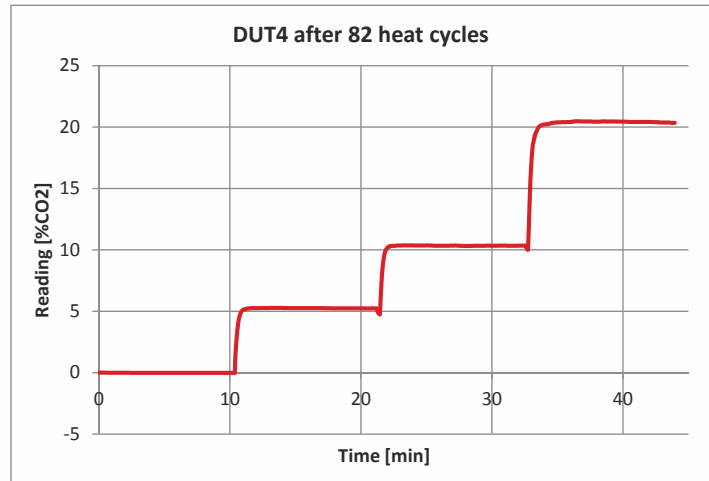

Figure 4. Gas cylinder and test cell used for the CO₂ measurement (left). Example of the recorded CO₂ readings at the four test concentrations (right).

Results

Figure 5 shows the changes in the probe readings during the test with respect to the initial state. The long-term stability specification of one year is included in each plot (solid black line). It should be noted that as the sterilization is performed monthly in typical applications, the number of tested cycles (137) corresponds to more than ten years of typical operation. It is observed that the readings are very stable, do not show any clear trend with increasing high-temperature exposure, and are well within the one-year stability specification in all cases.

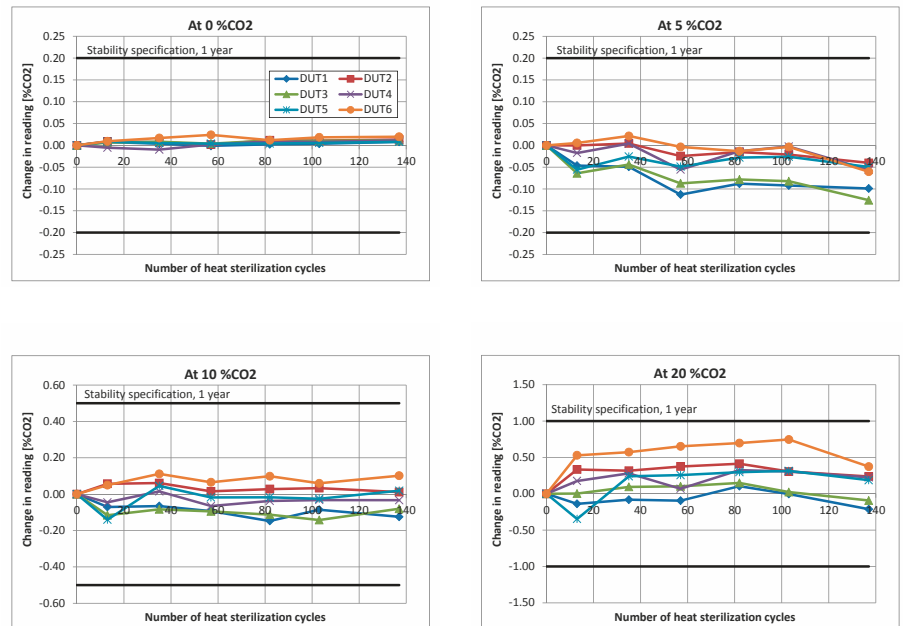

Figure 5. Results of the heat sterilization stability test.

Stability in Typical Incubator Conditions

Methods

The stability of the Vaisala GMP231 in typical incubator conditions was tested with five probes adjusted and calibrated before the test according to the normal manufacturing procedure. The probes were installed into a life science CO₂ incubator (240 liters) through the back wall (Figure 6). The incubator temperature was 37 °C and relative

humidity around 93 % RH; these conditions were monitored using a Vaisala HUMICAP® Humidity and Temperature Transmitter HMT333. To characterize the stability, the probes were removed from the incubator and their readings were measured at four CO₂ concentrations (0, 5, 10, and 20 % CO₂) by using certified reference gas cylinders (AGA,

relative uncertainty 0.5 %) at room temperature. At each concentration, the reading was calculated as an average of five minutes' data (300 points). Changes in the ambient pressure were compensated by using the internal pressure sensor of the probe. After the gas measurements, the probes were re-installed into the incubator.

Results

The stability of the probes during the test (200 days) is plotted in [Figure 7](#) along with the long-term stability specification of one year. Again, the results show stable behavior over time and all devices are well within the specification.

Conclusions

The Vaisala GMP231 is an infrared CO₂ probe that can withstand incubator heat sterilization up to 195 °C. This paper describes the stability of the Vaisala GMP231 in two conditions: heat sterilization cycles (40 ... 195 °C, 137 cycles) and typical incubator conditions (37 °C, 93 % the RH, 200 days). The tests were conducted by exposing the probes to the test conditions and recording their CO₂ readings at laboratory conditions several times during the test by using certified reference gases. The results show very stable behavior in all the tested cases.



Figure 6. GMP231 probes installed for the incubator test. Outside view (left), inside view (right).

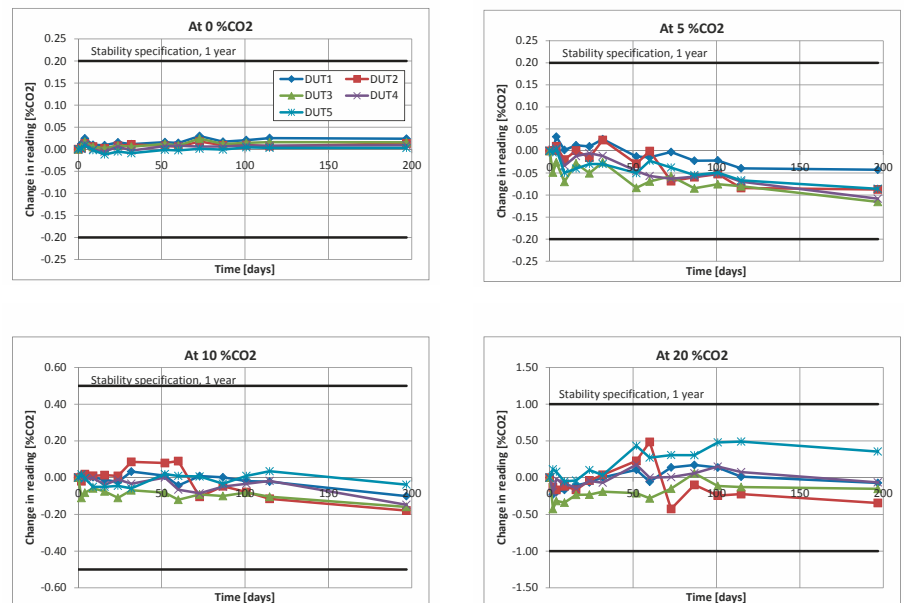

Figure 7. Results of the stability test in the incubator conditions (37 °C, 93 % RH).

VAISALA

Please contact us at
www.vaisala.com/contactus



Scan the code for
more information

Ref. B211378EN-B ©Vaisala 2018

This material is subject to copyright protection, with all copyrights retained by Vaisala and its individual partners. All rights reserved. Any logos and/or product names are trademarks of Vaisala or its individual partners. The reproduction, transfer, distribution or storage of information contained in this brochure in any form without the prior written consent of Vaisala is strictly prohibited. All specifications – technical included – are subject to change without notice.

www.vaisala.com