

Axiom AN

Valve communication and control
for challenging environments

StoneL[®]

Exceptional
reliability

Universal
application

User-friendly
advanced
technology





StoneL products proven in

- Chemical
- Oil and gas
- Pharmaceutical and biotech
- Food and beverage
- Marine
- Offshore service vessels (OSV)
- Biofuels
- And more...

Advanced performance

The Axiom AN offers unmatched reliability using non-contact position sensing with solid state electronics and contaminant-tolerant pneumatic control. Coupled with its space-efficient design, corrosion resistance and networking/Wireless Link capability, the AN offers unrivaled convenience and cost-saving benefits in hazardous and general purpose process applications.

Exceptional reliability

The proven technologies combined with efficient design and durable materials, delivers long life and exceptional performance.

- Survives harsh conditions
- Tolerates air contaminants
- Provides solid state position-sensing

Universal application

The strategic engineering reduces inventory and ensures universal adaptability in many applications and environments.

- Universal voltage capability
- Selectable SR/DA action
- Direct actuator attachment

User-friendly advanced technology

Designed with the user in mind, the Axiom AN offers the utmost in ease and convenience.

- Rapid enclosure entry
- Easy configuration
- Convenient wiring access
- Wireless Link app set up



See StoneL.com/approvals for current approvals.



Impact-resistant cover

Vapor tight, Lexan® cover screws off for rapid entry without tools. It withstands high-pressure wash downs and typical process environment corrosives.

Universal voltage solenoid system

Operates from 24 VDC – 250 VAC at extended temperate range and features manual override. Single or dual coil available.

Convenient settings

Touch pad enables position settings to be conveniently locked in. Switch settings remain in place during power cycling.

High flow pneumatic valve

5-way, 2-position valve operates on standard plant air. Rebreather prevents ingestion of contaminated air into actuator.

Fully sealed module

Solid state, fully potted sensors provide protection against residual moisture, vibration, and corrosives.

High visibility indication

Mechanical and electronic indication confirms open and closed position. Intense LEDs display position status from a distance.

Exceptional long life

Magnetic position sensor has no bushings or shafts to wear out, delivers reliable performance, and is unaffected by actuator shaft wear.

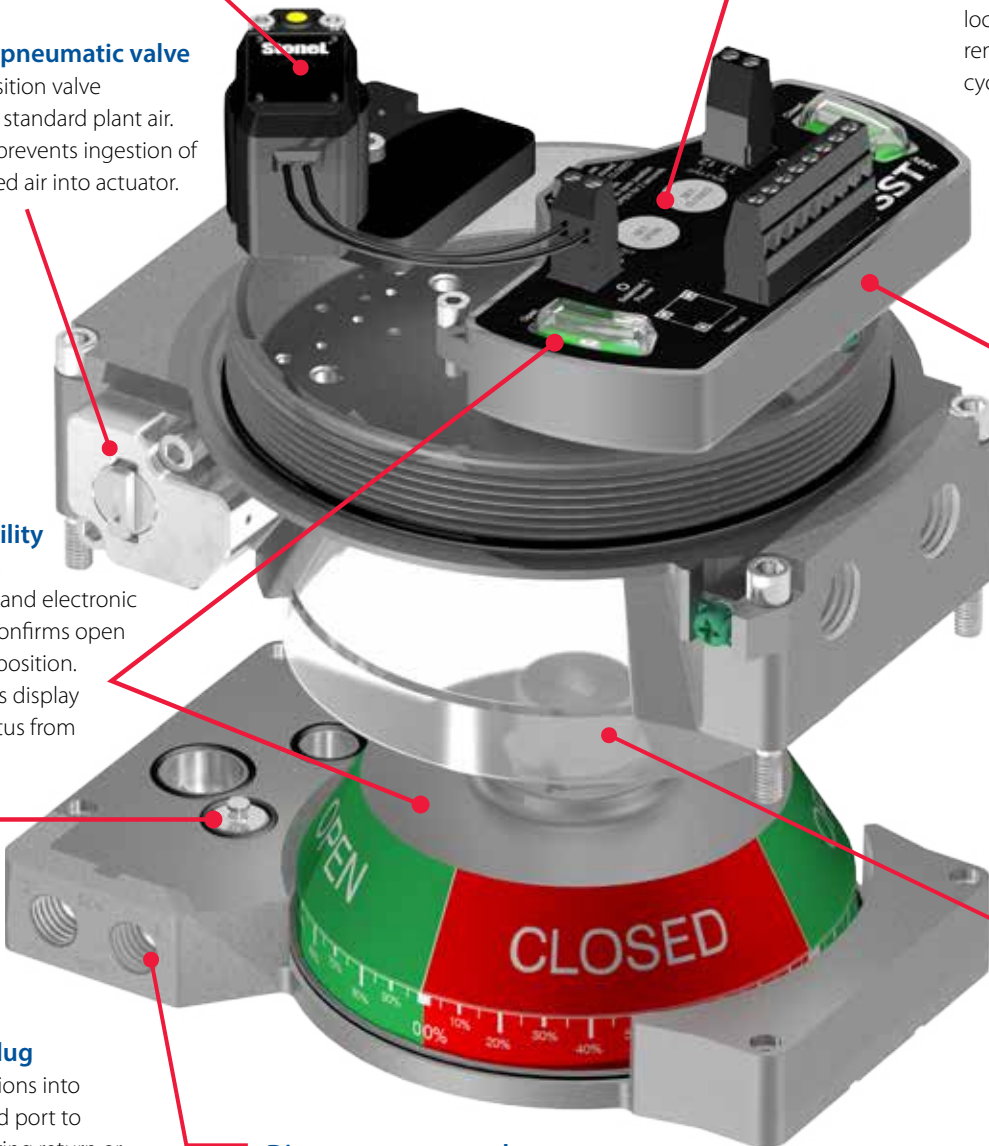

SR/DA plug

Plug positions into designated port to enable spring return or double-acting operation.

Direct actuator attachment

Compact mounting manifold system requires less space and wiring, connects to VDI/VDE 3845 (NAMUR) actuators and adapts to spring return or double-acting actuators.



User-friendly advanced technology

Convenient switch setting

The touch sensors have no moving parts; just hold your finger for two seconds on the button to set. The bright LED indication confirms that you have successfully set the position. Communication models allow you to configure and set the sensors using your smart phone or tablet; no cover removal needed!

Reliable position sensing

An extremely reliable solid state magnetic resistive (mag res) sensor detects the valve position by monitoring the orientation of a magnet attached to the actuator. This design is tolerant of lateral and vertical shaft movement, which may occur in heavily used actuators, without affecting rotational measurement.

Easy everything

You will save maintenance time and trouble with the user-friendly design offering easy attachment, easy cover removal, easy access to wiring right on top, easy access to internal pneumatic manual overrides and easy component replacement.

Single or dual pilot configuration

The Axiom AN is available in either single or dual pilot configurations. Dual pilot options are available for shuttle piston, fail-in-last position applications. Several external manual override options are also readily available. For special valve configurations with non-standard manual override features, please consult StoneL.

High-visibility LED indication

Clearly view valve position status with the high-visibility LED indicators. The LEDs offer easy viewing from a distance with the high intensity lighting that can be identified even in sunlight.

Networking with Wireless Link

Both the AS-Interface and DeviceNet models offer dramatic installation cost savings and have optional Wireless Link, with an iOS app. This feature offers unrivaled convenience and maintenance savings during the automated valve's entire life cycle. You may remotely access your valves from up to 50 meters, depending on obstructions.



Pneumatic manual override is conveniently located on top for easy access.



Touch sensors and LED indicators make set up fast and easy.

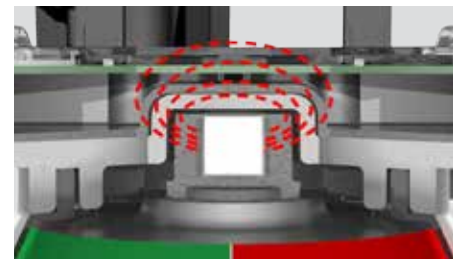

No cams, shafts or seals - offering exceptional vibration tolerance and nothing to wear out.

Universal application

The Axiom is designed to readily adapt to most quarter-turn actuators. The mounting manifold system combines the mounting base and pneumatic manifold to minimize space and simplify installation. It attaches the Axiom directly to the actuator and ports air from the pneumatic valve to the actuator.

Included in the manifold system are:

1. Actuator shaft adaptor and fastener.
2. Epoxy-coated anodized aluminum mounting plate manifold with o-rings and stainless steel fasteners.
3. Pneumatic plug for SR/DA configuration.

The manifold system readily adapts to VDI/VDE 3845 sizes 1, 2 and 3. Special variations may be made for sizes 3, 4 and non-standard quarter-turn actuator mounting patterns.

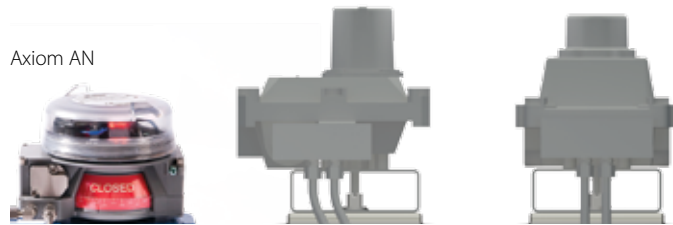
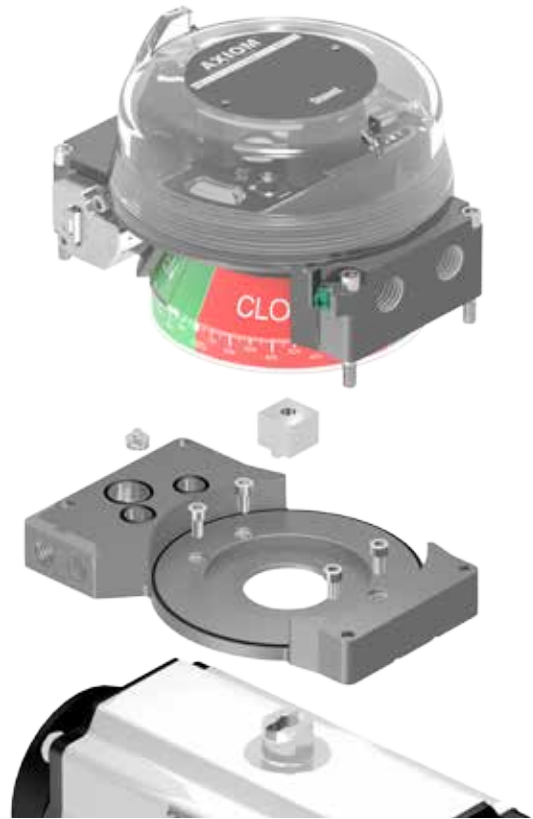

Axiom AN

The Axiom AN's compact size requires less than 5" of clearance.

The mounting manifold system is specified and sold separately. Kits are specific to actuator manufacturer. For kit numbers visit: StoneL.com/mounting.



Integral pneumatics

The Axiom's pneumatic valve system consists of a solenoid pilot that drives the main high-flow spool valve. Pilots are automatically associated with the appropriate function selected.

Special features

- Solenoid pilot and main spool design offer long life, exceptional tolerance to dirty air, and tight shut-off.
- Universal voltage solenoid system may be used for standard AC or DC applications.
- Five-way, two-position spring return configuration may be used for either single- or double-acting actuators. Dual coil shuttle piston versions are also available for fail-in-last position.
- Rebreather channels exhausted air from pressurized side of actuator into spring side, preventing ingestion of contaminated air from the environment that may corrode springs or actuator internals.

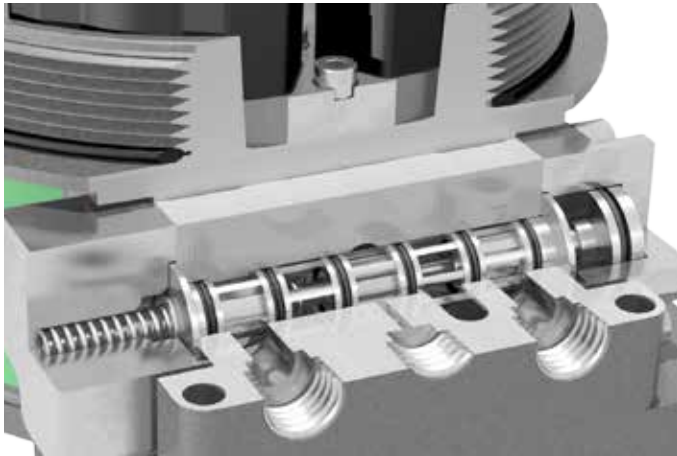

General pneumatic valve specifications		
Valve design	Pilot operated spool valve	
Configuration	Single pilot Dual pilot	5-way, 2-position, spring return 5-way, 2-position, shuttle piston
Flow rating	0.8 Cv 1.2 Cv	
Axiom porting	¼" NPT (0.8 Cv) ⅜" NPT (1.2 Cv)	
Manifold porting	¼" NPT	
Operating pressure	45 psi to 120 psi (3.1 to 8.2 bar)	
Operating temperature	-40° C to 80° C (-40° F to 176° F)	
Operating life	1 million cycles	
Manual override	Internal momentary Optional external momentary available Optional external latching available	
Materials of construction	Spool Body Seal spacers Spool seals O-rings End-caps and fasteners	Nickel plated aluminum Epoxy-coated anodized aluminum Polysulfone Nitrile compound Nitrile compound Nickel plated aluminum and stainless steel
Solenoid coil specifications		
35		
Operating voltage	40 - 250 VAC; 20 - 55 VDC	
Power consumption	20 mA @ 40 - 250 VAC (1.1 watts typical) 20 mA @ 20 - 55 VDC (0.5 watts typical @ 24 VDC)	
Inrush current	0.14 A @ 24 VDC (typical)	
Filtration requirements	50 micron	
45		
Operating voltage	12 - 24 VDC (output of barrier)	
Power consumption	0.5 watts @ 12 VDC; 1.0 watt @ 24 VDC	
Filtration requirements	50 micron	
92 & 97		
Operating voltage	24 VDC	
Power consumption	0.5 watts	
Filtration requirements	50 micron	

Single or double-acting configuration

The same Axiom AN model is suitable for both single-acting/spring return (SR) and double-acting (DA) actuators. The standard rebreather capability for single-acting/spring return is built in. Field configuration may be made by conveniently removing and reinserting the plug for the appropriate actuator type. For rebreather to function properly, both manifold ports must be tubed to the actuator.

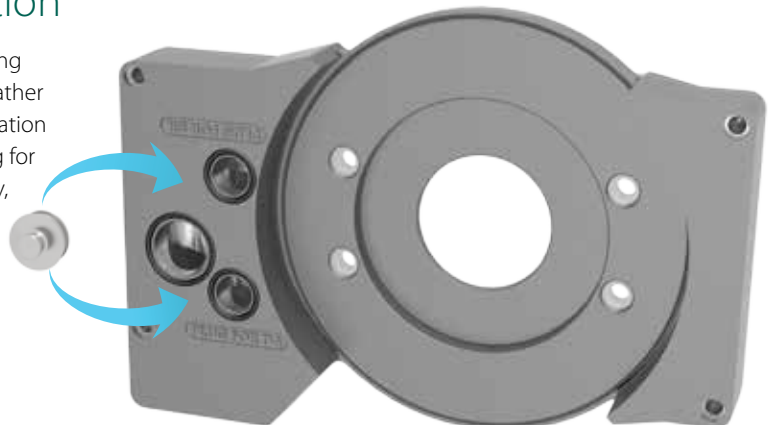

Proven sensing and communication

The Axiom platform has all position sensing, communication or switching integrated into StoneL's C-module. Users may set open/closed positions conveniently and accurately on all modules. And easy to view instructions, along with bold LED indication, are displayed on the module itself.

Continuous sensing with open/closed settings

The C-module (continuous sensing) integrates a magnetic resistive sensor system to monitor exact valve position throughout the rotational range. Touch-sensitive or remote open and closed position setting along with microprocessor based operation make this state-of-the-art system convenient, reliable, and smart.

Position settings are made using the touch-sensitive buttons on the module's overlay. Simply operate the actuator to the open position (using standard internal manual override) and touch the SET OPEN button. Operate the actuator to the closed position and touch the SET CLOSED button. Position settings remain locked in when power is removed and reapplied.

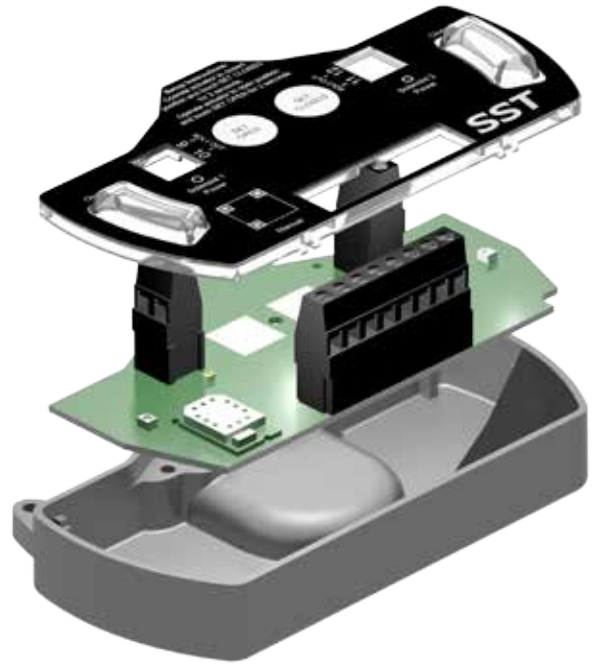

Conventional I/O network

Valve monitors and valve controllers are often controlled and monitored using conventional I/O. In these cases, the position feedback is wired back to a PLC/DCS discrete input (DI) card. The solenoid valves are wired to and operated by a discrete output (DO) card. The Axiom solid state sensors are designed to work with the vast majority of DI/DO cards enabling compatibility with most PLC/DCS systems and a wide array of different voltages.

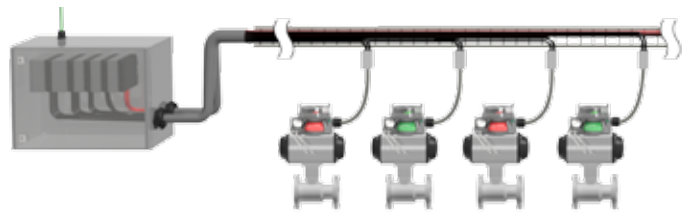

Switching and sensor specifications	
SST NO sensor (35S)	
Configuration	(2) NO 2-wire solid state sensors
Voltage range	20 - 250 VAC/VDC
Minimum on current	2.0 mA
Maximum continuous current	0.1 amps
Typical leakage current	AC circuits 0.35 mA DC circuits 0.25 mA
Typical voltage drop	6.5 volts @ 10 mA 7.2 volts @ 100 mA
Circuit protection	Protected against short circuits and direct application of voltage with no load.

Wiring diagram (35S)

Switching and sensor specifications	
NAMUR sensor (45S)	
Configuration	(2) NAMUR sensors (EN 60947-5-6; IS)
Voltage range	5 - 25 VDC
Current ratings	Target present current < 1.0 mA Target absent current > 2.1 mA
<i>Use with intrinsically safe repeater barrier. NAMUR sensors conform to EN 60947-5-6 standard.</i>	
Intrinsically safe solenoid coil	
Voltage	12 - 32 volts from output of solenoid barrier to coil*
<i>*Note: Use of an intrinsically safe solenoid barrier with internal impedance, or end-to-end resistance, of ≤ 500 ohms required for proper solenoid coil operation.</i>	

Wiring diagram (45S)

Communication (bus) network

In a communication network system many devices, such as valve communication terminals and other process instruments, can be connected to a single cable back to the DCS/ PLC. Power and signal for all of the devices is carried over the network. Each device has its own address and it may have several I/O points.

AS-Interface is a versatile, low cost alternative to traditional hard wired I/O. It can replace traditional point-to-point wiring with a better, more flexible solution that is easier to install, operate and maintain and easier to re-configure. DeviceNet is another versatile, cost saving alternative to traditional hard wired I/O. It can replace traditional point-to-point wiring with a better, more flexible solution that saves money on installation and maintenance.

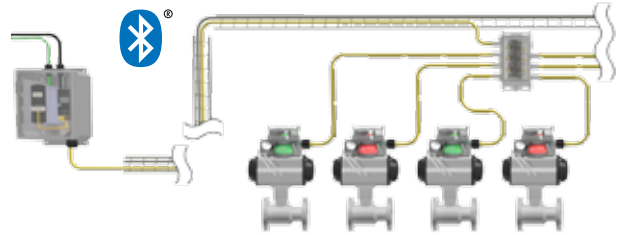

Valve Communication Terminal (VCT) specifications	
DeviceNet™ communication (92S & 92W)	
Communication protocol	DeviceNet™
Configuration	(2) Discrete inputs (sensors) (1) Auxiliary analog input (4-20 mA) (2) Discrete outputs (solenoids)
Input voltage	11 - 25 VDC via DeviceNet™ network
Output voltage	24 VDC
Analog input impedance	254 ohms
Quiescent current	No analog input, no outputs energized: 35 mA @ 24 VDC; 57 mA @ 11 VDC
Maximum output current	150 mA (all outputs combined)
Default address	63 (software assigned)
Default baud rate	125K (software selectable 125K, 250K or 500K baud)
Messaging	Polling, cyclic and change of state
DeviceNet™ type	100
Wiring diagram (92S & 92W)	

Valve Communication Terminal (VCT) specifications	
AS-Interface communication and extended addressing (97S & 97W)	
Communication protocol	AS-Interface v3.0
Configuration	(2) Discrete inputs (sensors) (2) Auxiliary discrete inputs (2) Discrete outputs (solenoid)
Input voltage	26.5-31.6 VDC (AS-I voltage)
Output voltage	24 VDC (+/- 10%)
Quiescent current	35 mA
Maximum output current	100 mA (all outputs combined)
Default address	0A
ID/IO codes	ID = A; IO = 7; ID1 = F; ID2 = E (S-7.A.E.)
Wiring diagram (97S & 97W)	

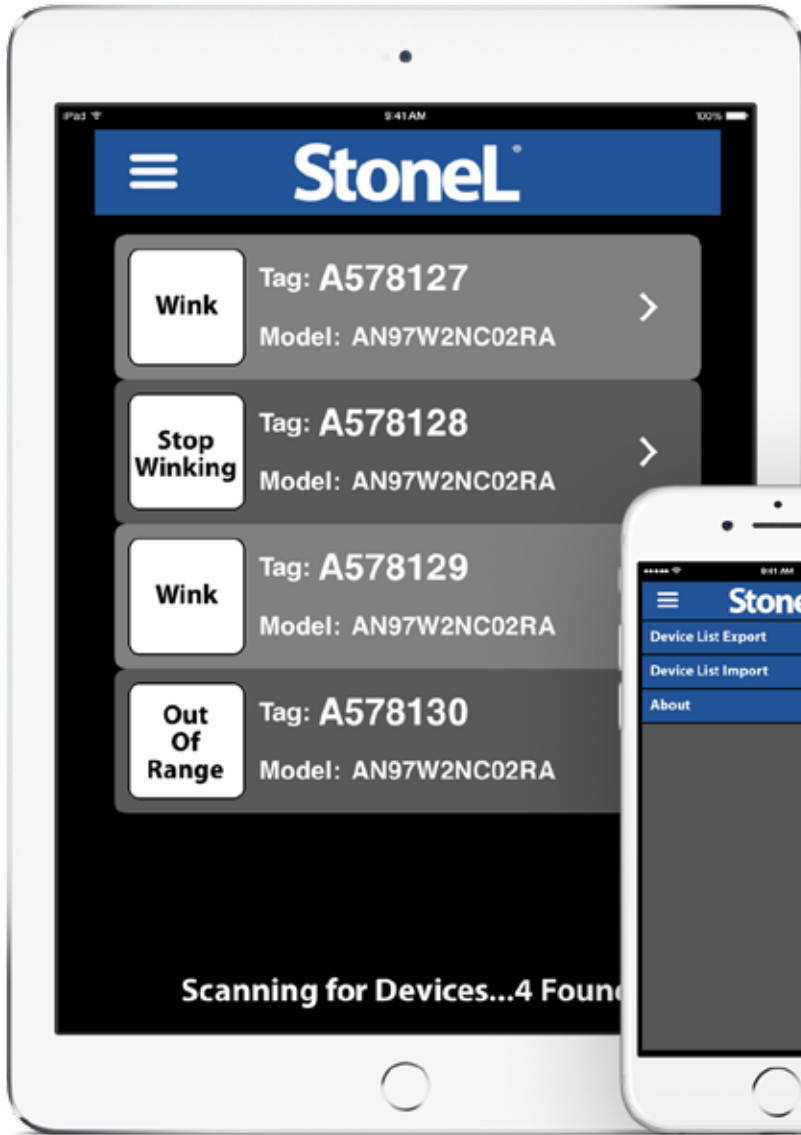

Axiom AN with Wireless Link



You can import and export electronic tags, model number, serial number, device address, descriptive fields, diagnostic data and more to and from standard CSV/Excel® files.



Conventional iPhone® and iPad® devices may be used. Contact StoneL regarding additional devices and special enclosures to make these devices suitable for use in hazardous locations.



Customize the tag for a device, change the address, force the solenoids on or off, wink the device, and set the valve limits.



Store and view additional information about a specific valve.

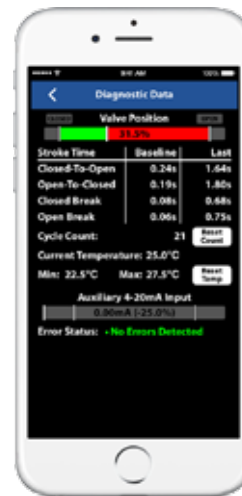

View real time valve position, cycle count, cycle timing, current valve temperature, error status, and more.

Easily access hard-to-reach automated valves

Discover convenient remote access of your automated valves when you install the Axiom AN with AS-Interface and DeviceNet featuring *Bluetooth®* technology. Devices may be remotely accessed from up to 50 meters depending on obstructions. Setting changes and solenoid control are enabled through the DeviceNet or AS-Interface network or by the AS-Interface power supply jumper.

All settings and inputs are locked when standard network communication is functioning.



Benefits of Wireless Link

1. Fast, convenient set-up for valve automation suppliers without special equipment.
2. Electronically enter and store key automated valve system information including:
 - End user tag number/information
 - Valve and actuator identification as well as Axiom model and serial number (Axiom information preset from factory)
 - Maintenance log.
3. Improve safety by easily accessing hard-to-reach automated valves without putting plant personnel at risk.
4. Reduce network commissioning time by accessing the VCT address and making changes if necessary.
5. Reduce maintenance time by monitoring valve cycle count, cycle times, storing maintenance logs, and accessing multiple valves from one location.
6. Conveniently retrieve installation manuals and access StoneL website when connected to Internet.

Specifications for Wireless Link	
Communication	<i>Bluetooth®</i> technology; single mode (not compatible with <i>Bluetooth Classic</i>)
Transmit power	4dBm or ~2.5 milliwatts
Data rate	1 Mbit/second; effective information transmit rate ~10 Kbits/second
Range	Up to 100 meters (330 feet) in free space. Range is reduced by obstructions between hand-held device and Wireless Link VCT. Line of site is not necessary.
Registrations	FCC, IC, CE
CE compliance	Exceeds industrial compliance standards
VCT identification	VCTs in range will be displayed in order of signal strength
VCT link	One device accessed at a time between client (hand-held device) and server (VCT). Each server accessed by one client at a time
Application	StoneL Wireless Link available from the App store
Hand-helds	Compatible with iPhone® and iPad® with iOS 8 or later

Model selector

SERIES

AN Nonincendive or intrinsically safe

FUNCTIONS

Sensor/ switching modules

35S SST Universal; 20 - 250 volt (NO sensor)
 45S NAMUR module (EN 60947-5-6; I.S.)

Valve communication Terminals (VCTs)

92S DeviceNet™
 92W DeviceNet™ with Wireless Link
 97S AS-Interface with extended addressing
 97W AS-Interface with extended addressing and Wireless Link

PNEUMATIC OVERRIDE / CV [standard pneumatic pilot and valve -40° C to 80° C]

For single pilot

1N Internal momentary override only / 0.8 Cv
 1M External momentary & internal override / 0.8 Cv
 1L External latching & internal override / 0.8 Cv
 1E Internal momentary override only / 1.2 Cv
 1Y External momentary & internal override / 1.2 Cv
 1G External latching & internal override / 1.2 Cv
 9N No pneumatics

For dual pilot

2N Internal momentary override only / 0.8 Cv
 2M External momentary & internal override / 0.8 Cv
 2L External latching & internal override / 0.8 Cv
 2E Internal momentary override only / 1.2 Cv
 2Y External momentary & internal override / 1.2 Cv
 2G External latching & internal override / 1.2 Cv

ENCLOSURE

Clear cover

C North American (NEC/CEC)
 D International (IEC)

Aluminum cover

A North American (NEC/CEC)
 V International (IEC)

CONDUIT/CONNECTORS

Standard

02 (2) ½" NPT
 05 (2) M20

Mini-connectors

10 (1) 4-pin
 11 (1) 5-pin
 19 (1) 6-pin
 20 (1) 7-pin
 21 (1) 8-pin

Micro-connectors (M12)

13 (1) 4-pin
 15 (1) 5-pin
 17 (1) 6-pin
 18 (1) 8-pin

VISUAL INDICATOR

RA Red closed/green open
 GA Green closed/red open

1A Three-way 1
 2A Three-way 2

XA Special

Model number example

AN 35S 1L C 02 RA - OPTIONAL

MODEL NUMBER

Mounting hardware required and sold separately.

PARTNERSHIP ID

Some models may include 5-digit identification suffix.

Visual indicator designations

Clearly view valve position status from up to 75 feet with the Axiom's visual indicator. The indicator's rugged Lexan® construction makes it resistant to physical damage and tolerant to most corrosives.



Designation	0°	90°
R	Red closed	Green open
G	Green closed	Red open
1		
2		
X	Specialty configuration - please consult factory	

Dimensions

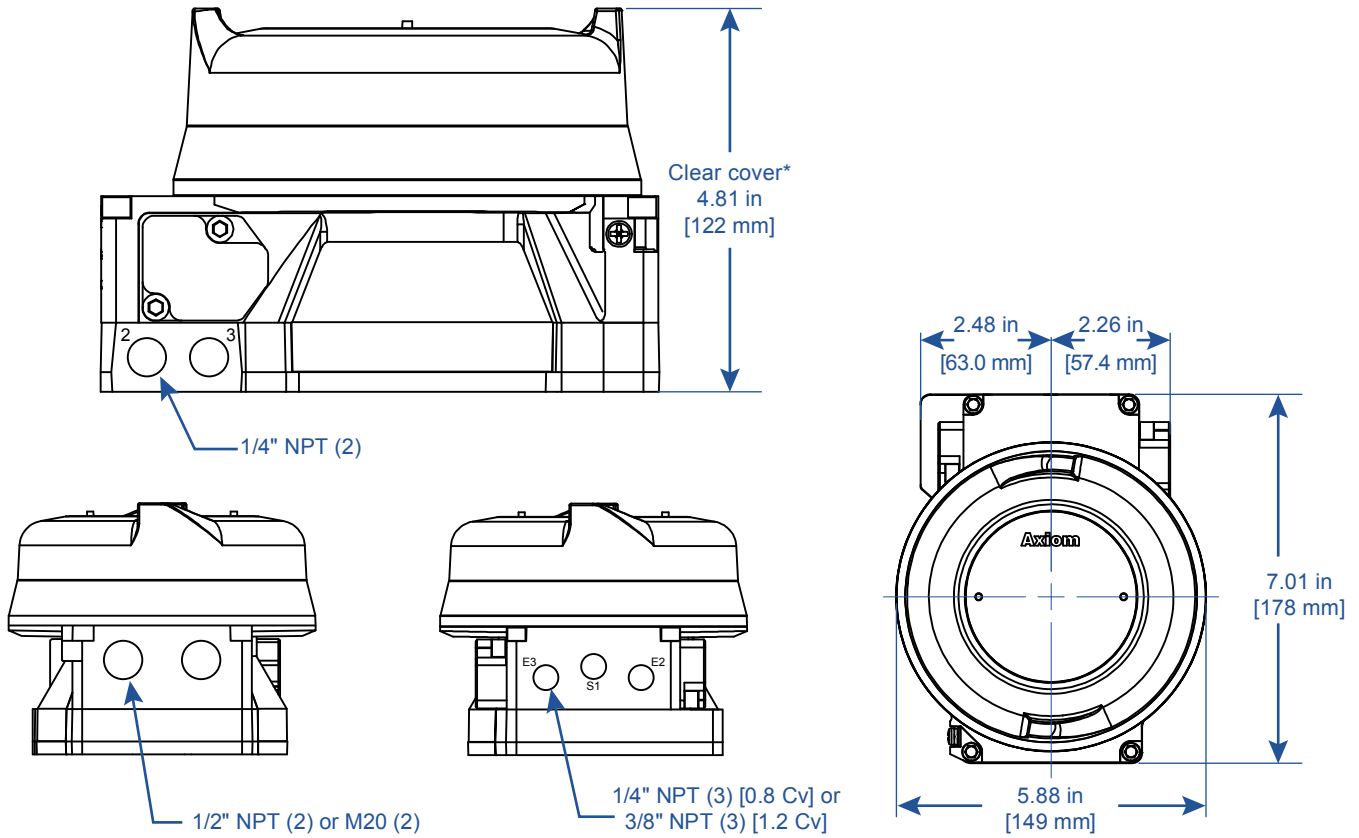

* Aluminum cover 4.90 in [125 mm]

Specifications	
Materials of construction	
Housing and air manifold plate	Epoxy-coated anodized aluminum
Visual indicator drum	Nylon
Visual indicator cover	Polycarbonate
Fasteners	Stainless steel
O-rings	Nitrile compound
Operating life	1 million cycles
Temperature range	-40° C to 80° C (-40° F to 176° F)
Warranty	
Sensing and communication module	Five years
Mechanical components	Five years
Unit weights	
Aluminum	2.38 kg / 5.25 lb
Unit dimensions	
Unit height	122 mm [4.81 in]
Cover removal clearance	214 mm [5.80 in]

Position sensing	
Accuracy	Within 1°
Repeatability	Within 1°
Setting buffer	4° from setpoint (<i>Rotational distance from original setpoint where switch will energize on return stroke</i>)
Dead band	6° from setpoint (<i>Rotational distance from original setpoint where switch will de-energize</i>)
Max rotational range	120°
Ratings	
Nonincendive (<i>Class I and II, Div. 2</i>)	All models*
Intrinsically safe (<i>Ex ia Zone 0; Class I and II, Div. 1</i>)	Function 45S only*
Enclosure protection	
Type 4, 4X and 6	All models
Ingress Protection 66/67	All models
Approvals*	
	See StoneL.com/approvals
* Only models listed on StoneL's official website are approved per specific rating.	

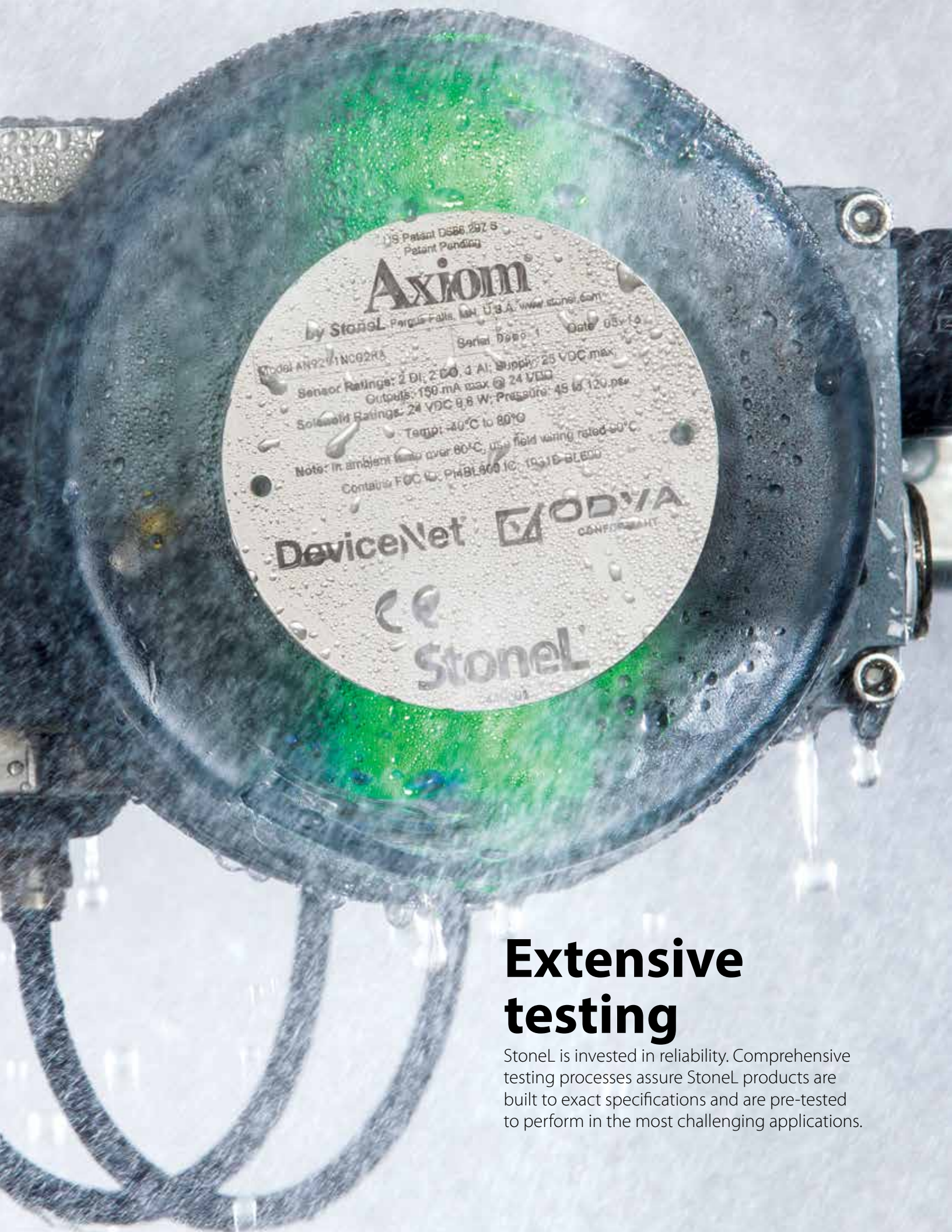

US Patent D666 297 S
Patent Pending

Axiom

by Stonel, Piquette Falls, OH, U.S.A. www.stonel.com

Model AN9211NC02R6 Serial Date 1 Date 05v16

Sensor Ratings: 2 DI, 2 DO, 3 AI; Supply: 25 VDC max
Outputs: 150 mA max @ 24 VDC
Solenoil Ratings: 24 VDC @ 8 W; Pressure: 45 to 120 psi
Temp: -40°C to 80°C

Note: In ambient water over 80°C, use field wiring rated 90°C
Contains FCC ID: P441800 IC: 1931B-BLEDD

DeviceNet  MODVA
CONFIDENTIAL

CE

Stonel

400 01

Extensive testing

Stonel is invested in reliability. Comprehensive testing processes assure Stonel products are built to exact specifications and are pre-tested to perform in the most challenging applications.

From our product development



To your application



Robust testing of all components.

Mechanical



- Acids
- Actuator shaft eccentricity
- Aging effects
- Caustic mixtures
- Chlorine
- Conduit strength
- Cycle life
- High pressure spray
- Icing
- Impact resistance
- Ingress protection
- Operational positions
- Organic oils
- Organic solvents
- Petroleum based substances
- Salt fog
- Steam pressures spray
- Submersion
- Temperature extremes
- Ultraviolet tolerance
- Vibration

Electrical



- Circuit heat rise
- Current and voltage limits
- Cycle life
- Electrostatic discharge immunity
- Leakage current
- Network protocol compatibility
- Operational positions
- Over current protection
- Position sensor accuracy (triggering, dwell, dead band)
- Power cycling
- Radio frequency interference
- Reverse polarity
- Temperature extremes
- Thermal cycling
- Thermal shock
- Vibration
- Voltage tolerance

Pneumatic



- Cycle life
- Dirty (solids) air tolerance
- Flow rate
- Housing pressure relief
- Oils tolerance
- Operation on nitrogen
- Operational positions
- Pressure limits
- Temperature extremes
- Vibration
- Water tolerance

Install with confidence



Hazardous location compliance



Built to last with reduced maintenance



Optimized performance

Proven performance from the inside out





StoneL[®]

Valve Communication Solutions

26271 US Highway 59, Fergus Falls, MN 56537

USA

Tech hotline +1 218 737 0701

Tel. +1 218 739 5774, fax +1 218 739 5776

Email: sales@stoneL.com

StoneL.com

Publication Number

VP-713-12/16

