

# VALVE COMMUNICATION AND CONTROL

LINEAR ON/OFF SANITARY DIAPHRAGM VALVE CONTROLLER

PRISM  
PI





## Prism PI

### Intelligent features offer advanced performance

The Prism PI integrates an advanced position sensing system and integral pneumatic control for sanitary diaphragm and other linear applications.

Compact and durable, the PI is suited for corrosive, heavy washdown and hazardous areas.

#### Advanced position sensing

With the continuous solid state mag res sensor system, the PI offers the ultimate in ease of set-up, reliability and consistent performance. Push button or remote setting is simple and quick with bold mechanical, as well as LED visual position status.

#### Integral pneumatic control in compact, vapor tight enclosure

Position sensing system and control valve are enclosed in a vaportight submersible enclosure with convenient screw on cover access. Pneumatic solenoid valve is available in standard high flow. Settings and wiring may be conveniently accessed for quick set-up and maintenance.

#### Compact design for convenient adaptability to linear valves

The PI offers precision feedback for valve stroke lengths varying from 4 mm (0.13") up to 66 mm (2.6"). Options include three cover heights, the low profile version with no visual indicator and a medium or tall cover version both with a visual indicator. With the low profile version, the unit is less than 76 mm (3") above actuator mounting pads and may accommodate stroke lengths up to 28 mm (1.1").



Compact design



Standard stroke with no visual indicator

Standard stroke with visual indicator

Long stroke with visual indicator

## Features

1. **Suitable for high pressure washdown** and temporary submersion, the PI is rated for NEMA 4, 4X and 6 (IP66 & 67).
2. **Screw-on cover** enables convenient access without tools.
3. **Enclosure is made of high impact strength**, corrosion-resistant polycarbonate.
4. **Prominent visual indicator** boldly displays mechanical position status.
5. **Low profile design** minimizes height clearance required above actuator.
6. **All electronics are sealed** inside the linear C-module to protect against contamination, shock and vibration.
7. **Intelligent high accuracy position sensor** is solid state with no moving parts for long life. Sensor automatically adjusts dead band based on stroke length.
8. **Integral solenoid valve available** with Cv of 0.20.
9. **NPT pneumatic connections** are stainless steel reinforced for long life sealing under high torque stress conditions.
10. **Push button open and closed** settings are made conveniently and quickly. (AS-Interface unit may have settings made remotely.)
11. **LED light bar** brightly displays open, closed and solenoid status.
12. **Conduit entries available** in NPT, metric threads or quick connectors.

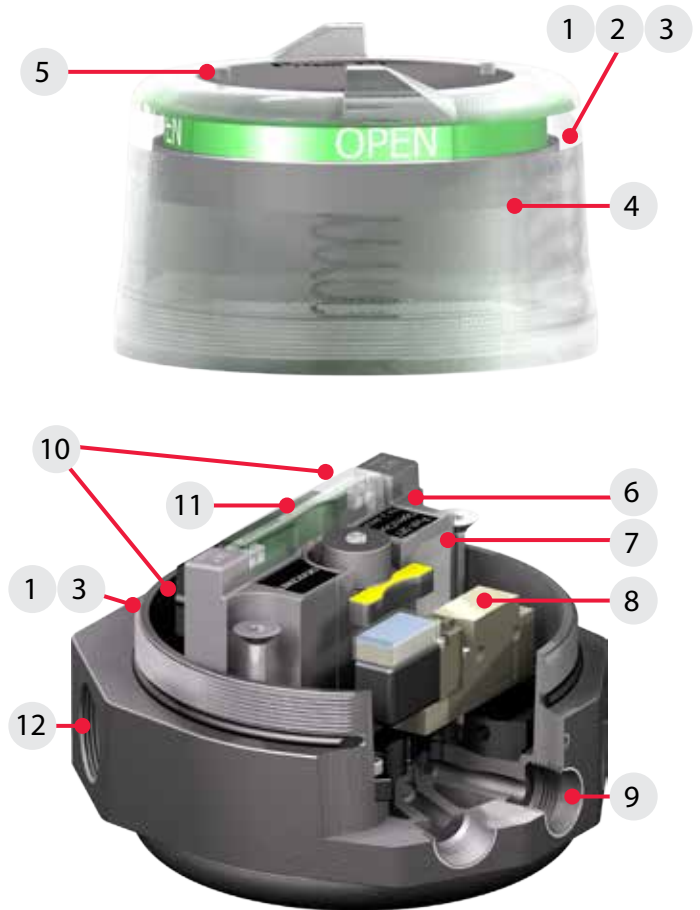

## Prism mounting system

Prism adapting systems are designed for each actuator using a standardized system that minimizes the required space envelope. Mounting components include:

- **Standardized rugged mounting plate** allowing for rotational flexibility and compact secure attachment.
- **Actuator fasteners made of stainless steel** and tailored for each specific mounting application.
- **Shaft coupler made of stainless steel** and designed to conveniently attach the magnetic trigger to actuator shaft.

Complete mounting adaption is performed in minutes! With no moving wear-parts long-life is assured. And, the trigger system is impervious to thermal shock and vibration.



## Position sensor module

The PI features an intelligent linear magnetic resistive sensor system to precisely measure stroke position at all times. Features include:

- **High accuracy** over wide operating temperature range.
- **Automatic tuning** of open and closed deadband depending on stroke length (See below).
- **High intensity LEDs** in module light bar which reflect on enclosure cover for visibility of switch status even in brightly lit areas.
- **Fully potted and sealed** making it resistant to high G vibration forces and moisture.
- **Convenient, simple push button settings** accurately locking in open and closed positions, which remain in place when power is removed and reapplied.



Convenient push button settings and high intensity LEDs

## Automatic tuning

The intelligent sensing system offers precise feedback. Set-up is performed in seconds with high precision in the closed position and no false switching in varying open positions.

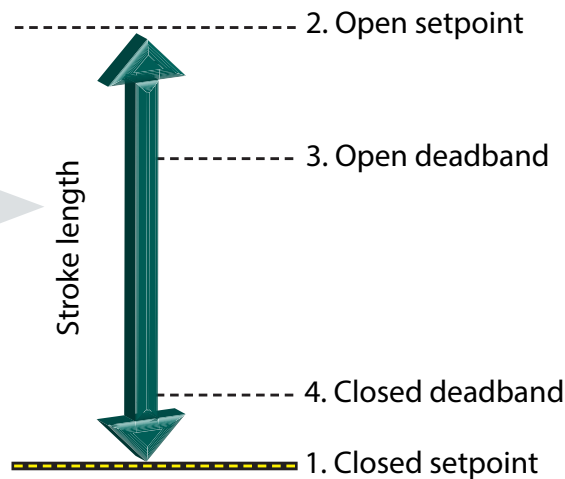
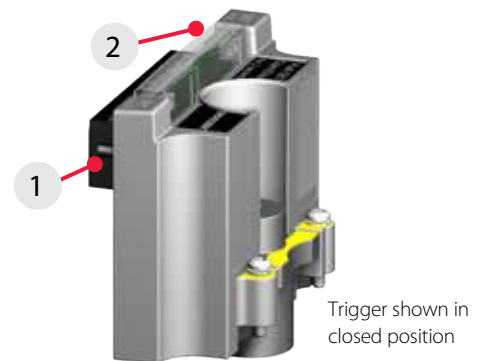

### Easy set-up

1. Push button to set closed (2 seconds).
2. Push button to set open (2 seconds).
3. Open deadband is automatically set to 30% of full stroke length, eliminating false switch feedback from “floating” due to pressure variations.
4. Closed deadband is automatically set to 3.8 mm (0.150”), or 30% of stroke, whichever is less, providing precise closed indication.

# Sensing and communication module

The Prism features StoneL's linear module system with field proven reliability in all on/off applications. Outputs are available as SST (switching) and VCTs (valve communication terminals).

Modules have a **five year warranty**.



### Switching and sensor specifications

#### SST switching sensors (33)

Configuration	Linear solid state sensors (2) Wire terminations for one solenoid
Operation	Select NO (33) model
Maximum current inrush	1.0 amp @ 125 VAC/VDC
Maximum current continuous	0.10 amp @ 125 VAC/VDC
Minimum on current	2.0 mA
Maximum leakage current	0.5 mA
Voltage range	20 - 125 VAC/VDC
Maximum voltage drop	6.5 volts @ 10 mA 7.5 volts @ 100 mA

**Wiring diagram (33)**

**SST**

### Sensor specifications

#### NAMUR sensor (45)

Configuration	(2) NAMUR sensors (EN 60947-5-6; I.S.) Wire terminations for one solenoid
Operation	Normally closed NAMUR sensors (solid state)
Voltage range	7 - 24 VDC
Current ratings	Target on <1 mA Target off >3 mA

**Wiring diagram (45)**

**NAMUR**

### Valve Communication Terminal (VCT) specifications

#### DeviceNet™ (92S & 92W)

Configuration	(2) Discrete inputs (open and closed) 92W (2) Remote sensor settings 92W (1) Wink feature (2) Power outputs (solenoids) (1) 4-20 mA auxiliary analog input, 10-bit resolution; no additional power source required
Transmission rate	Software selectable 125K, 250K or 500K baud
Messaging	Polling, cyclic and change of state
Outputs	4 watts @ 24 VDC both outputs combined
Output voltage	24 VDC (with input voltage ranging from 10 - 24 VDC)
Other features	Predetermined output fail state

**Wiring diagram (92S & 92W)**

**DeviceNet**

\* 4-20 mA transmitter not included

### Valve Communication Terminal (VCT) specifications

#### AS-Interface (96S) and AS-Interface with extended addressing (97S & 97W)

Configuration	(2) Discrete sensor inputs 96S, 97S (2) Auxiliary discrete inputs (1) Power output (solenoid)
Maximum current	96S 160 mA 97S 100 mA 97W 160 mA
Auxiliary inputs	24 VDC @ 2.5 mA (self-powered)
Output	96S 4 watts @ 24 VDC 97S 2 watts @ 24 VDC 97W 4 watts @ 24 VDC
Outputs, voltage	21 - 26 VDC
Profile	96S ID=F, IO=7; (4DI/4DO) 97S ID=A, IO=7; (4DI/3DO) 97W ID=A, IO=7; (4DI/3DO)
AS-i version	3.0
Devices per network	96 31 97 62
Features	96 Wink and remote setting 97 Wink

**Wiring diagram (96S) and (97S & 97W)**

**AS-i**



## Prism PI with Wireless Link

### Easily access hard-to-reach automated valves

Discover convenient remote access of your automated valves when you install the Prism PI with DeviceNet™ or AS-Interface featuring *Bluetooth®* technology.

Devices may be remotely accessed from up to 50 meters depending on obstructions. Setting changes and solenoid control are enabled through the DeviceNet™ network.

### With the new patent pending *StoneL Wireless Link* app you can remotely:

- Monitor and set open and closed switch positions
- Monitor and set the network address
- Monitor and set the baud rate
- Operate solenoid valve(s) (if network- or power supply-enabled)
- Identify model and serial number (preset from factory)
- Identify valve automation components (entered by valve supplier)
- Log maintenance information
- Monitor diagnostics (valve cycle count, electronics temperature, and more).



### Set up and operation

The Prism PI with Wireless Link is commissioned and set up identically to the standard DeviceNet™ or AS-Interface unit. In addition, when powered up with a conventional power source or by the network, it may be accessed by standard iOS devices. The Prism PI is accessed with the *Bluetooth®* protocol using the *StoneL Wireless Link* application. Sequence of operation is:

1. Download the *StoneL* application from the App Store onto your device (free of charge)
2. Start the application in your Apple® device

3. All energized wireless modules in range will come up
4. Push wink to positively confirm the device you have linked (Prism LEDs will flash)
5. Touch the specific Prism ID/tag to link with your handheld.

You can then monitor all status and diagnostic information and make necessary information changes to the free form fields at any time. Switch settings, addressing, baud rate changes and solenoid operation may be performed only if network- or power supply-enabled. Other information may also be added to the free form fields.

## Benefits of Wireless Link

- Fast, convenient set-up** for valve automation suppliers without special equipment.
- Electronically enter and store** key automated valve system information including:
  - End user tag number/information
  - Valve and actuator identification as well as Prism PI model and serial number (Prism information preset from factory)
  - Maintenance log.
- Improve safety by easily accessing hard-to-reach automated valves** without putting plant personnel at risk.
- Reduce network commissioning time** by accessing the VCT address and baud rate for making changes if necessary.
- Reduce maintenance time** by monitoring valve cycle count, storing maintenance logs, and accessing multiple valves from one location.
- Conveniently retrieve installation manuals** and StoneL website when connected to internet.

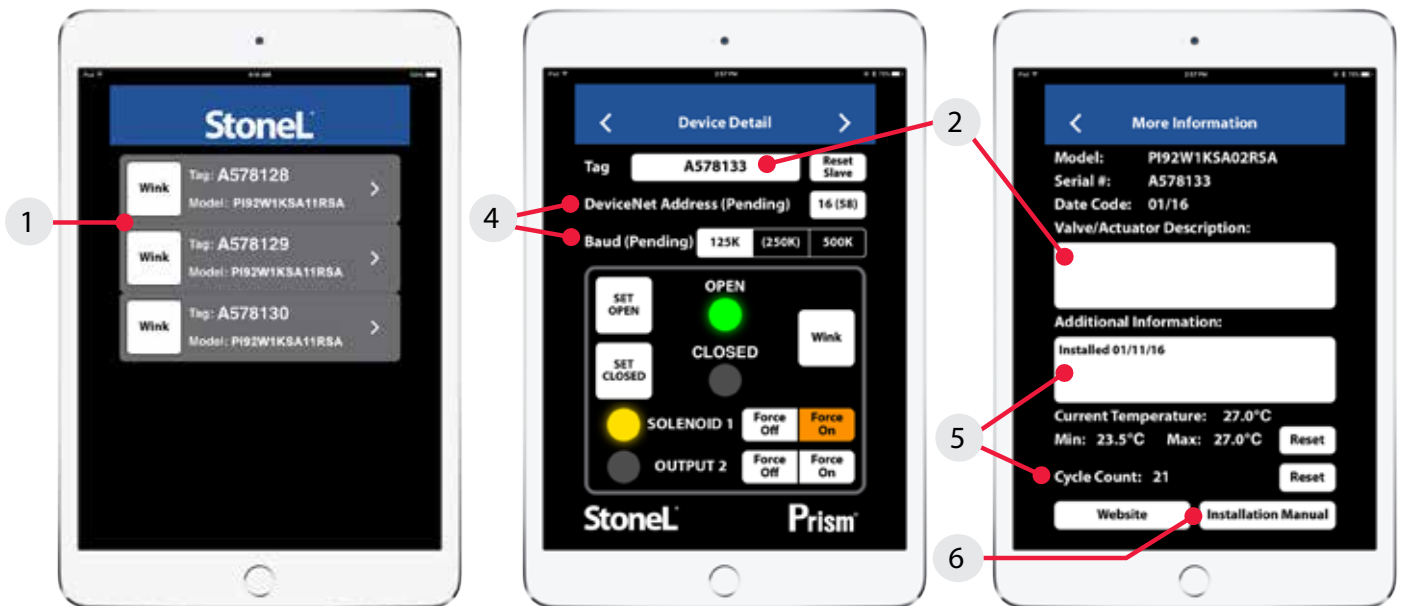

Specifications	
Standard specifications apply to Prism PI92W & PI97W. Additional specifications for Wireless Link are as follows:	
Protocol	Bluetooth® technology; Single mode (not compatible with Bluetooth® Classic)
Transmit power	4 dBm or ~2.5 milliwatts
Data rate	1Mbit/second; effective information transmit rate ~10 Kbits/second
Range	Up to 100 meters (330 feet) in free space. Range is reduced by obstructions between handheld device and Wireless Link VCT. Line of sight is not necessary.
Registrations	FCC, IC, CE
CE compliance	Exceeds industrial compliance standards
VCT identification	VCTs in range will be displayed
VCT link	One device accessed at a time between client (handheld device) and server (VCT). Each server accessed by one client at a time.
Application	"StoneL Wireless Link" available from the App store
Handhelds	Compatible with iPhone® and iPad® with iOS 8 or later

### Interfacing devices

Conventional Apple® devices may be used including:

- iPhone® Version 4S and above
- iPad® Version 3.0 and above
- iPad mini™ All

Contact StoneL regarding additional devices and special enclosures to make these devices suitable for use in hazardous locations.



# Pneumatic control and other specifications

Three-way, two-position spring return pneumatic valve features a standard Cv of 0.1 or 0.2, operating most actuators in less than two seconds. The valve is completely isolated from the environment enabling pneumatic control to be located in the field with no threat of contamination.

## Solenoid valve

This high flow solenoid valve operates at low power and is well-suited for most applications. It features a convenient manual override for stroking during set-up and commissioning.



## Valve schematic

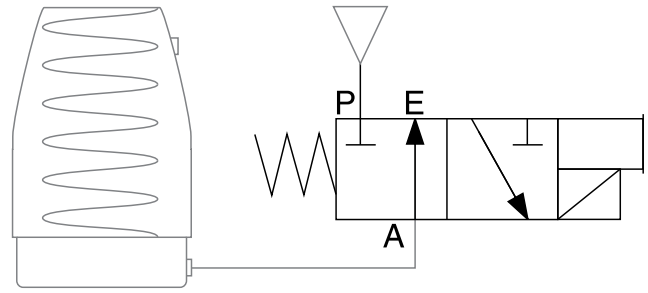

Specifications	
<b>Solenoid valve</b>	
Configuration	3-way, 2-position, spring return
Porting	1/8" NPT (stainless steel reinforced)
Flow rating	1NS Cv 0.1 1KS Cv 0.2 1MS Cv 0.2
Operating pressure	25 psi to 140 psi
Filtration requirements	40 micron
Electrical ratings	1NS 12 mA @ 120 VAC; 20 mA @ 24 VDC (voltage power depends on function) 1KS 1.0 watts @ 24 VDC 1MS 1.0 watts @ 120 VAC
Inrush	Negligible

## Dimensions Inches [mm]

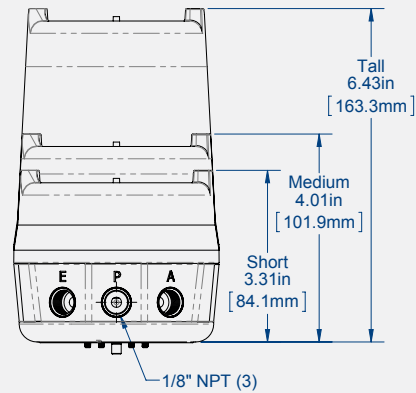
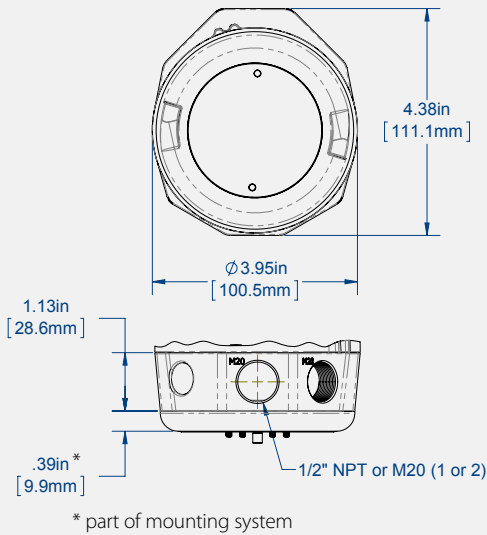



Model selector	
<b>SERIES</b>	
PI	Intelligent nonincendive
<b>FUNCTIONS</b>	
<b>Sensor modules</b>	
33S	(2) SST NO switching sensors [select pneumatic valve option 1KS, 1MS, 1NS or 11S]
45S	(2) NAMUR sensors (EN 60947-5-6; I.S.) [select pneumatic valve option 1NS or 11S]
<b>Valve Communication Terminals (VCTs)</b>	
92S	DeviceNet™ [select pneumatic valve option 1KS, 1NS or 11S]
92W	DeviceNet™ with Wireless Link [select pneumatic valve option 1KS, 1NS or 11S]
96S	AS-Interface [select pneumatic valve option 1KS, 1NS or 11S]
97S	AS-Interface with extended addressing [select pneumatic valve option 1KS or 11S]
97W	AS-Interface with extended addressing and Wireless Link [select pneumatic valve option 1KS, 1NS or 11S]
<b>PNEUMATIC VALVE / TEMPERATURE</b>	
<b>-20° C to 60° C / 0.1 Cv</b>	
11S	No pneumatic valve
1NS	Three-way voltage / power depends on function
<b>-10° C to 50° C / 0.2 Cv</b>	
1KS	Three-way 24 VDC 1.0 watt
1MS	Three-way 120 VAC 1.0 watt
<b>ENCLOSURE</b>	
A	North American (NEC/CEC)
V	International (IEC)
L	Other
<b>CONDUIT ENTRIES</b>	
01	(1) ½" NPT
02	(2) ½" NPT
04	(1) M20
05	(2) M20
10	(1) 4-pin mini-connector
11	(1) 5-pin mini-connector
13	(1) 4-pin micro-connector
15	(1) 5-pin micro-connector
17	(1) 6-pin micro-connector
19	(1) 6-pin mini-connector
<b>VISUAL INDICATOR</b>	
R	Green open
0	No indication
<b>VALVE SIZE</b>	
SM	¼" to 2" (3.2 mm to 28.5 mm; ½" to 1 ½" stroke)
LM	¼" to 6" (3.2 mm to 66.8 mm; ½" to 2 ½" stroke)
Model number example	
PI	33S 1KS A 01 R SM - OPTIONAL
<b>MODEL NUMBER</b>	
<b>PARTNERSHIP ID</b>	
Mounting hardware required and sold separately.	
Some models may include 5-digit identification suffix.	

Specifications	
<b>Materials of construction</b>	
Cover	Clear polycarbonate
Housing and mounting manifold	Fiber reinforced polycarbonate
Fasteners	Stainless steel
Valve manifold	Integral with stainless steel reinforced NPT
Trigger system (magnetic)	Polysulfone with black chromated zinc reinforcement
<b>Position sensor system</b>	
Accuracy	1.0 mm (.040")
Repeatability	0.5 mm (.020")
Setting buffer	Open: 25% of stroke length Closed: 25% of stroke length up to 3.2 mm (.125")
Deadband	Open: 30% of stroke length (variable; based on stroke length) Closed: 30% of stroke length or 3.8 mm (.150") (whichever is less)

Temperature ratings (pneumatic valve dependent)		
<b>Operating temperature</b>	11S, 1NS 1KS, 1MS	-20° C to 60° C (-4° F to 140° F) -10° C to 50° C (14° F to 122° F)
<b>Operating life</b>	Over 1 million cycles	
<b>Warranty</b>		
Electronic module	Five years	
Mechanical components	Two years	

Ratings	
Nonincendive <i>(Ex n, Zone 2 or Class I and II, Div. 2)</i>	PI models*
Intrinsically safe <i>(Ex ia, Zone 0 or Class I and II, Div. 1)</i>	Function 45*
<b>Enclosure protection</b>	
NEMA 4, 4X and 6	All models
Ingress Protection 66 and 67	All models
<b>Approvals*</b>	See StoneL.com/approvals
* Only models listed on StoneL's official website are approved per specific rating.	

**Metso Flow Control Inc.**

**Europe**, Vanha Porvoontie 229, P.O. Box 304, FI-01301 VANTAA, Finland.  
Tel. +358 20 483 150. Fax +358 20 483 151

**North America**, 26271 US Hwy 59, Fergus Falls, MN 56537, USA.  
Tel. +1 218 739 5774. Fax +1 218 739 5776

**South America**, Av. Independência, 2500- Iporanga, 18087-101, Sorocaba-São Paulo, Brazil.  
Tel. +55 15 2102 9700. Fax +55 15 2102 9748/49

**Asia Pacific**, Haw Par Centre #06-01, 180 Clemenceau Avenue, Singapore 239922.  
Tel. +65 6511 1011. Fax +65 6250 0830

**China**, 11/F, China Youth Plaza, No.19 North Rd of East 3rd Ring Rd, Chaoyang District,  
Beijing 100020, China. Tel. +86 10 6566 6600. Fax +86 10 6566 2583.

**Middle East**, Roundabout 8, Unit AB-07, P.O. Box 17175, Jebel Ali Freezone, Dubai,  
United Arab Emirates. Tel. +971 4 883 6974. Fax +971 4 883 6836

**[www.metso.com/valves](http://www.metso.com/valves)**

Subject to change without prior notice.

