

CPU and EFHU Fixture Hangers

Explosionproof, Dust-Ignitionproof

UNILETS® for use with Threaded Metal Conduit.

NEC/CEC:

- Class I, Division 1 and 2, Groups C, D
- Class II, Division 1 and 2, Groups E, F, G
- Class III

Applications

- Fixture hangers and accessories for suspension of industrial type HID, incandescent, and fluorescent lighting fixtures in Class I, Class II, and Class III classified locations.
- Suitable for use in areas where moisture, dust and corrosive atmospheres are present.
- CPU and EFHU, EFHC, have smooth, rounded integral bushing in each hub to protect conductor insulation.

Features

- Boxes have cast mounting lugs. Box and hub cover provide a complete assembly for suspending lighting fixtures in classified locations.
- CPU20 Hangers are used where fixture stem is less than 12" long or with EXJF, ESD, or ESS where fixture stem is more than 12" long.
- EFHU Flexible Hangers meet NEC Sec. 501 requirement for flexible suspension where fixture stem is more than 12" long.
- Cushion design protects against vibration, and swivel action (any direction up to 15° from vertical) protects fixture if accidentally struck.
- EFHU Flexible Cushion Hangers available in three spring ranges to support fixture weights of 5.4kg to 21.8kg (12 to 48 lbs) and 21.8kg to 54.4kg (48 to 120 lbs).
- CB205 Connection Block available for connecting all wires without splices.
- Ground-joint mating surfaces assure flame-tight fit.
- Hanger has setscrew in stem hub to prevent fixture stem from turning.

Standard Materials

- CPU and EFHU: malleable iron or copperfree (4/10 of 1% max. aluminum)
- EFHU flexible hanger: brass fixture stem hub assembly

Standard Finishes

- CPU20 rigid fixture hangers body: triple-coat – (1) zinc electroplate, (2) chromate, and (3) epoxy powder coat
- CPU20 rigid fixture hangers cover: zinc electroplate and clear chromate
- Separate CPU20 covers: zinc electroplate and clear chromate.
- EFHU flexible cushion fixture hangers: triple-coat – (1) zinc electroplate, (2) chromate, and (3) epoxy powder coat

NEC/CEC Certifications and Compliances

- UL Listed: E10444
- UL Standard: 1203
- CSA Certified EFHU: 025428
- CSA Certified CPU: 013107

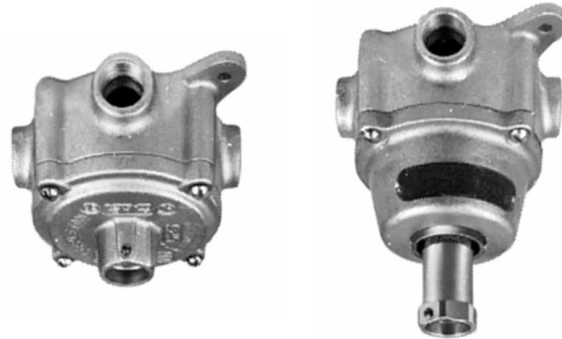

CPU

EFHU

Illustrated Features

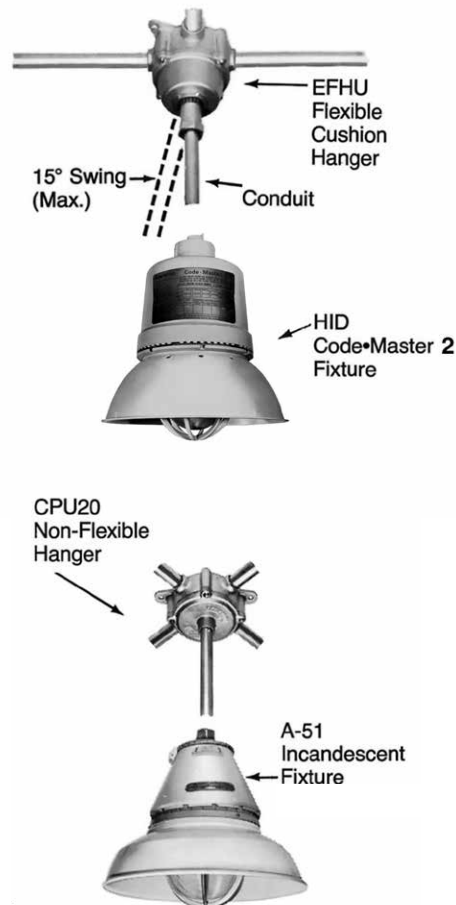

CPU and EFHU Fixture Hangers

Explosionproof, Dust-Ignitionproof

UNILETS® for use with Threaded Metal Conduit.

NEC/CEC:

Class I, Division 1 and 2, Groups C, D
 Class II, Division 1 and 2, Groups E, F, G
 Class III

POLES/HANGERS: NEC/CEC EXPLOSIONPROOF FLEXIBLE FIXTURE HANGERS

	Conduit Size (Inches)	Fixture Stem Size (Inches)	Support Weight kg (lbs)	NEC Catalog Number		CEC Catalog Number	
				Malleable Iron		Malleable Iron	Aluminum

CPU Fixture Hangers – Non-Flexible Type – Form 20



Furnished with cast mounting lugs, four threaded universal 3/4" hubs, four 3/4" to 1/2" reducers, and three 1/2" close-up plugs.

1/2 or 3/4	1/2	112.5 (250)	CPU20-50	CPU20-50CN	CPU20-50ACN
1/2 or 3/4	3/4	112.5 (250)	CPU20-75	CPU20-75CN	CPU20-75ACN

EFHU Fixture Hangers – Flexible Cushion Type – Form 20



Furnished with cast mounting lugs, four threaded universal 3/4" hubs, four 3/4" to 1/2" reducers, and three 1/2" close-up plugs.

1/2 or 3/4	3/4	5.4 to 21.6 (12 to 48)	EFHU75-48	EFHU75-48CN	—
1/2 or 3/4	3/4	21.8 to 54.0 (48 to 120)	EFHU75-120	EFHU75-120CN	—

CPU Fixture Hanger Covers – Non-Flexible Type – Form 20



Furnished with screws.

1/2	250/112.5	CPSK20-50	CPSK20-50CN	CPSK20-50ACN
3/4	250/112.5	CPSK20-75	CPSK20-75CN	CPSK20-75ACN

EFHU Fixture Hanger Covers – Flexible Cushion Type – Form 20



Furnished with screws. 3/4" to 1/2" reducer supplied for 1/2" fixture stem.

3/4	5.4 to 21.6 (12 to 48/)	EFH75-48	EFH75-48CN	—
3/4	21.8 to 54.0 (48 to 120)	EFH75-120	EFH75-120CN	—

CPU and EFHU Connection Block Accessory

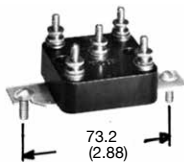

CB205



CB205CN

Mounts directly to drilled and tapped pads in CPU and EFHU hangers. Phenolic, with fastening strap and mounting screws.

5-Wire. 20-Amp, 300 V Max.	CB205	CB205CN	—
----------------------------	--------------	----------------	---

CPU and EFHU Fixture Hangers

Explosionproof, Dust-Ignitionproof

UNILETS® for use with Threaded Metal Conduit.

NEC/CEC:

Class I, Division 1 and 2, Groups C, D
 Class II, Division 1 and 2, Groups E, F, G
 Class III

POLES/HANGERS: NEC/CEC EXPLOSIONPROOF FLEXIBLE FIXTURE HANGERS

Dimensions in Millimeters (Inches)

CPU50 and CPU75 Rigid Fixture Hanger

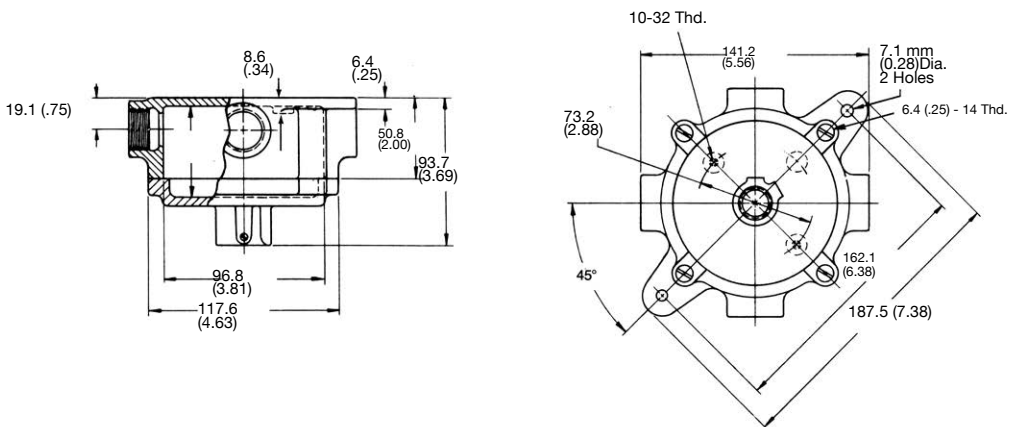

EFHU Flexible Cushion Fixture Hanger

